

Lawrence Berkeley National Laboratory

Recent Work

Title

A REMOTELY-OPERATED EXTERNAL TARGET SYSTEM FOR THE 88-INCH CYCLOTRON

Permalink

<https://escholarship.org/uc/item/9tz1t92d>

Authors

Miles, Leonard E.

Wigle, George L.

Bohm, Phillip A.

et al.

Publication Date

1962-07-01

University of California
Ernest O. Lawrence
Radiation Laboratory

TWO-WEEK LOAN COPY

*This is a Library Circulating Copy
which may be borrowed for two weeks.
For a personal retention copy, call
Tech. Info. Division, Ext. 5545*

Berkeley, California

DISCLAIMER

This document was prepared as an account of work sponsored by the United States Government. While this document is believed to contain correct information, neither the United States Government nor any agency thereof, nor the Regents of the University of California, nor any of their employees, makes any warranty, express or implied, or assumes any legal responsibility for the accuracy, completeness, or usefulness of any information, apparatus, product, or process disclosed, or represents that its use would not infringe privately owned rights. Reference herein to any specific commercial product, process, or service by its trade name, trademark, manufacturer, or otherwise, does not necessarily constitute or imply its endorsement, recommendation, or favoring by the United States Government or any agency thereof, or the Regents of the University of California. The views and opinions of authors expressed herein do not necessarily state or reflect those of the United States Government or any agency thereof or the Regents of the University of California.

For the 10th Hot Lab and
Eqpt Conf. - Wash. D. C.
Nov. 1962

UCRL-10368

UNIVERSITY OF CALIFORNIA

Lawrence Radiation Laboratory
Berkeley, California

Contract No. W-7405-eng-48

A REMOTELY-OPERATED EXTERNAL TARGET SYSTEM
FOR THE 88-INCH CYCLOTRON

Leonard E. Miles, George L. Wigle, Phillip A. Bohm, Robert G. Altes,
Thomas C. Parsons, and Patrick W. Howe

July 1962

A REMOTELY-OPERATED EXTERNAL TARGET SYSTEM* FOR THE 88-INCH CYCLOTRON

Leonard E. Miles, George L. Wigle, Phillip A. Bohm, Robert G. Altes,
Thomas C. Parsons, and Patrick W. Howe

Lawrence Radiation Laboratory
University of California
Berkeley, California

The target is placed in the external beam by a placement tube which moves the target from the attachment position to intercept the cyclotron beam beyond a 4-ft shielding wall. A new target and holder were designed to provide for much higher levels of induced activity and concentrations of heat than has been experienced at previous accelerators. The placement tube, which maintains the target-holder seal and the coolant utilities, travels in an airtight containment tube which, in turn, is connected through a plastic sock to the disassembly enclosure in a 6-in. lead cave. The active target is removed from the disassembly box by a sealed-bag passout system.

INTRODUCTION

Design Background. The design of the target-handling facility for the new 88-inch cyclotron at Lawrence Radiation Laboratory is a new approach to the servicing and handling of chemistry targets. Induced radioactivity in the target and holder is greatly increased over that in similar parts in previously operated accelerators. This requires that the "hotter" parts of the holder be removed before delivery of the target to the experimenter. The amount of heat generated by the beam striking the target is in the order of 20 kW per in.². The high induced activity in the target holder plus the greater need for heat dissipation made a new target design imperative.

Design Criteria. Beam measurements indicated the following calculated requirements:

1. Heat transfer to cool target: 23 kW in 0.7 in.² This requires 5 gallons of water per min at 30°F temperature rise and 20 ft³/min of helium at 40°F temperature rise.
2. Neutron flux from a deuteron bombardment of a thick beryllium target: 6×10^9 neutrons per cm² measured at 90° from beam path and 1 ft distant.
3. Induced activity in the target block: 100 roentgens per hour at 1 ft (gamma).
4. Rapid operation, essential because many of the isotopes produced are short-lived.

General Design. The target holder must hold the target in precise position in the beam, provide adequate seals to maintain the cyclotron vacuum and integrity of the target, and provide ample passages for flow of coolant. The target intercepts the beam outside the 10-ft shielding wall, Fig. 1. At this point the operator is protected from the high radiation field by the 4-ft wall of steel and concrete. After bombardment, the target is withdrawn through

*Work done under the auspices of the U. S. Atomic Energy Commission.

the 4-ft wall into the disassembly enclosure, where it is removed from its holder and passed out. The traveling tube was selected as the simplest means of positioning the target, since it could maintain the integrity of the system and also contain the coolant lines and other target utilities. The placement tube travels on ball bearing rollers inside a sealed enclosure tube which is connected by a sock to the disassembly enclosure, making the entire system as one enclosure.

CONSTRUCTION DETAILS

Target Block. The target block, Fig. 2, carries the target holder, Fig. 3, in position so that it can be sealed to the beam tube. The nose section carries the ring gasket for making this seal, a graphite collimator for stopping stray fringes of the beam, and water passages for cooling. The isolation section acts as an insulator and contains a magnetic field which prevents false current readings due to the loss of recoil electrons from the isolation foil back to the nose section and beam tube. The foil cover plate grounds the recoil electrons and seals the foil to the foil-cooling section. The foil-cooling section contains passages for helium circulation. Flow is directed through nozzle-like ports so as to sweep the isolation foil and target foil at high velocity for cooling. The holder receiver has a pocket to contain the target holder, Fig. 3. This unit slips into the target block and a seal is made between the block and block holder by a rectangular groove for an O ring around the opening. Water passages in the beam absorber direct the flow to the back of the target.

Positioning Tube. The inner section of the tube is 6 in. o. d. by 1/8-in. -wall stainless steel. This is attached to the outer 7-in. o. d. tube with special tapered screws into a transition collar. Sixteen inches of this section is filled with lead around the service tubes for shielding. At the front end of the tube, Fig. 4, are three rollers which engage the cams shown in Fig. 5. Next to the rollers is the receiver for the target block. Leaktight connections between the target block and header are made by O rings around each opening in the block pressed against the flat face of the header. The O rings are held in the target block by capture grooves, Fig. 4. The block is held against the face of the header by a pressurized diaphragm in the receiver at the forward end of the target block. The diaphragm is actuated through a self-sealing coupling by a pressure wand in the dismantling cave.

The outer section of the tube is 7 in. o. d. by 1/8 in. wall. At this end is the receiver for the service manifold, the drive-cable anchor, the rotation guides, and supporting rollers. Two pairs are mounted at the bottom at the front end of this section and two pairs at the top rear of this section. The forward 2/3 is filled with concrete to complete the shielding. Service hoses for the target coolant and electrical connections pass through the tube from the manifold header at the outer end to the target block header at the front end.

Service Manifold. The manifold is held in its receiver in the placement tube in the same manner as the target block. It is supported on the enclosure tube and positioned by an air-operated ram controlled through a solenoid valve by the operator.

Tube Drive. Drive for the placement tube, Fig. 6, is provided by a carefully controlled, reversible winch-driven cable. The drum is driven over a fixed screw of the same pitch as the drum winding. Since the cable always leaves the drum at the same point, this prevents rotational tendencies in the tube. Since the endwise movement of the drum is directly proportional to the position of the driven tube, this movement is used to actuate cams for microswitch control of the speed and location of the positioning tube. Power is supplied by an automatic variably controlled single-phase shunt-wound motor with 15-to-1 reductor. The control switch is within reach of the operator.

Bombardment Chamber. The bombardment chamber, Fig. 7, is an airtight box with flanges for attachment to the end of the cyclotron beam tube and to a bellows between the bombardment chamber and an 8-in. vacuum gate valve. At the left end of the chamber, shown in Fig. 5, with cover removed, can be seen the adjusting cams which precisely locate the target in the end of the placement tube. A ring seal attached to a double bellows is seen inside at the right. This is to seal the beam tube to the target block to permit evacuating the beam tube before the cyclotron is started. The annular space inside the double bellows is evacuated to break the seal and pressurized to make the seal. A 4-in. vacuum gate valve is located in the beam tube near the bombardment chamber. When this valve

EXTERNAL CYCLOTRON TARGET, Miles, et al.

is closed, the ring seal can be separated and the target withdrawn with the positioning tube. All flanges are gasketed and held together with toggle clamps to permit quick removal in case adjustments or repairs are needed.

Enclosure Tube. The enclosure tube between the 8-in. valve and an offset 18 in. inside the 4-ft wall is 6.5 in. o. d. by 1/8-in. - wall stainless steel. For the rest of the distance through the wall, it is 7.5 in. o. d. by 1/8-in. wall. These tubes are suspended inside a 12-in. tube filled with lead shot and water to complete the shielding. The outer part of the enclosure tube is 8 in. o. d. by 1/8-in. wall, mounted tangent at the bottom to permit a smooth track for the positioning tube rollers and more room at the top for the cable drive. Two side outlets are provided, one for a plastic sock connection to the dismantling enclosure and one for a flexible closure with the service manifold. Guide rollers are placed at intervals along the enclosure tube to engage longitudinal guides on the positioning tube.

Dismantling Enclosure. This enclosure, Fig. 1, is a low-leak box attached to the enclosure tube by a weldable sock in which the target block is disassembled and the parts passed out through a sealed bag passout system (1). The dismantling area is enclosed by a 6-in. lead cave. All operations are done inside the enclosure with tongs through "castle manipulators" (2) in the 6-in. cave wall.

Passout System. The passout shield, Fig. 8, and handling equipment were designed to provide 6 in. of lead shielding around the "hot" items at all times. A transfer cask for carrying hot items to the storage cells is mounted on an electric-powered lift truck. At the front of the cask is a lead door which is placed to engage a hook on the passout shield. As the cask is raised, the door is raised and locked in place. The cask is then lowered to align the two cavities and the hot item is transferred to the cask by a special tong in the cask. Storage cells in the wall facing the 6-in. cave are provided with 6-in. lead doors which are lifted open with a hoist. A door-to-door locking arrangement allows both doors to be opened to receive the items in the cask.

OPERATION

Installing Target. The target is assembled in the foil frame and an absorber is attached to complete the target-holder assembly. This is passed into the disassembly enclosure through the bag-out system and installed in the target block. The special tong places the block in the positioning tube, and the locking diaphragm is pressurized. Then the operator follows these steps. 1. Open isolation valve. 2. Retract knife-edged seal. 3. Open 8-inch gate valve. 4. Position the drive tube. 5. Check position. 6. Close knife-edged seal. 7. Evacuate beam tube (valve to seal). 8. Open 4-inch valve in beam tube. 9. Bombard target.

Removing Target. The following is the electrically controlled sequence of operations in removing and delivering target: 1. Turn off cyclotron beam and close 4-in. beam tube valve. 2. Evacuate water in service lines. 3. Reduce vacuum in beam tube. 4. Retract knife-edged seal. 5. When water is out, retract manifold. 6. Retract positioning tube. 7. Close 8-in. gate valve and isolation valve. 8. Extract target block. 9. Remove target holder. 10. Remove foil frame from absorber. 11. Pass out target in foil frame and deliver to experimenter. 12. Place absorber in holder behind additional shield. Check target block and enclosure for contamination. 14. If clean, reload block for next bombardment.

EXTERNAL CYCLOTRON TARGET, Miles, et al.**REFERENCES**

- (1) E. S. Fleischer et. al., "Remote Plastic Bag Passout Unit." Paper presented in Session VI Ninth Hot Laboratories and Equipment Conference and printed on page 339 of the proceedings.
- (2) William G. Ruehle Jr., "Shielding Manipulator for Radioactive Material." Nuclear Science Abstracts, Vol. 13, Item 21152, December 15, 1959.

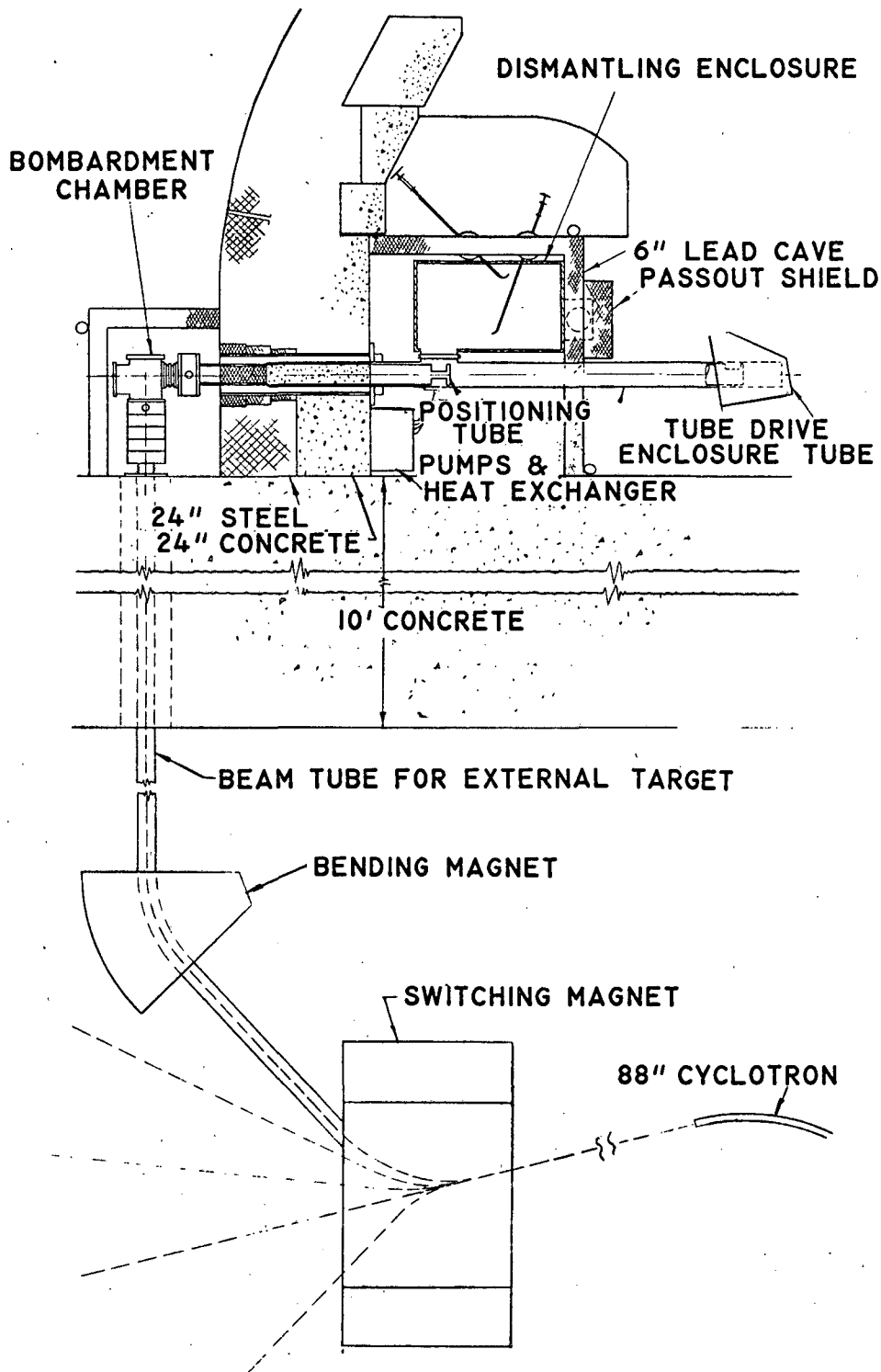

EXTERNAL TARGET SYSTEM OF 88" CYCLOTRON

MUB-1028

Fig 1

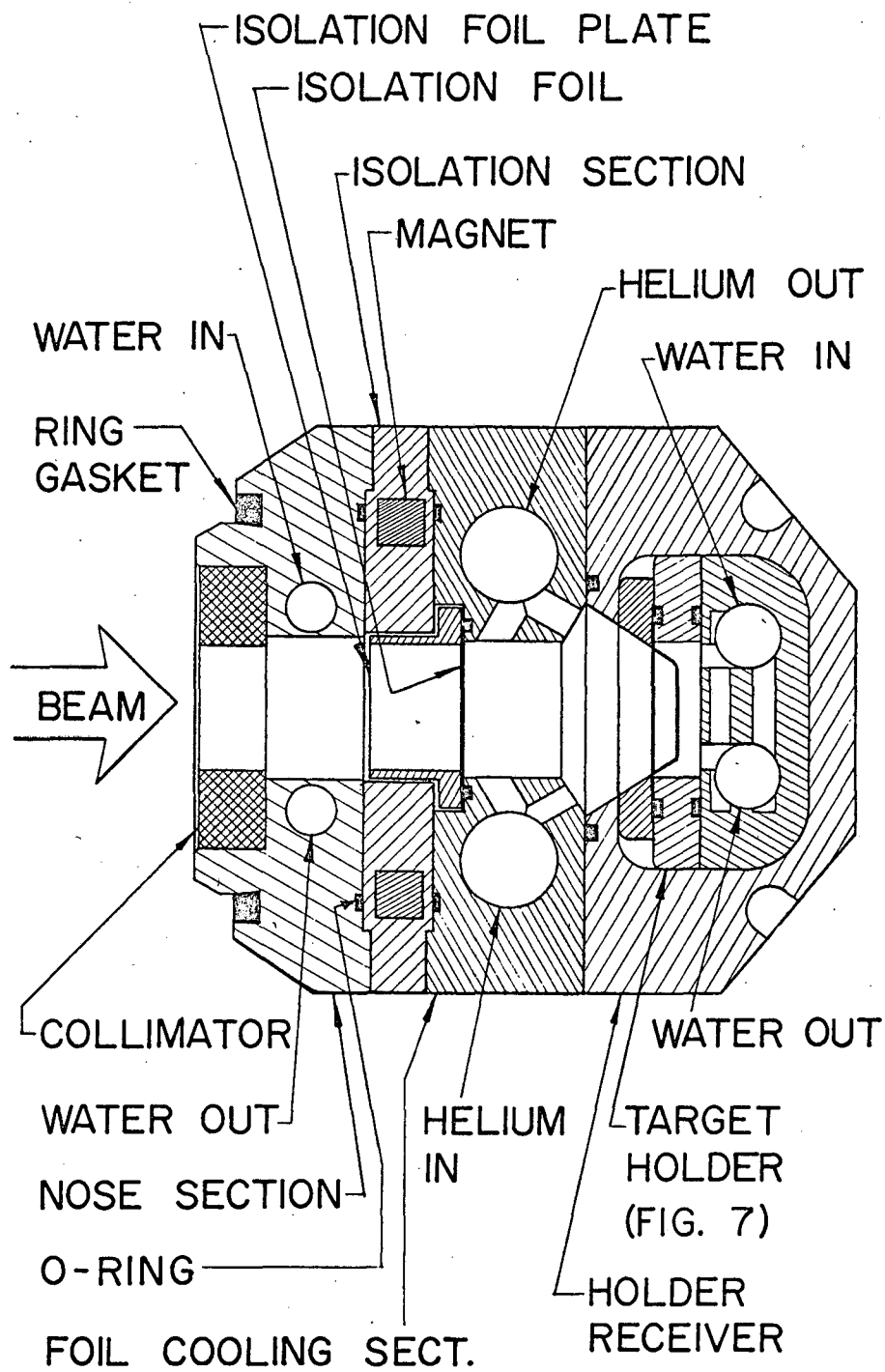

MUB-1210

Fig 2

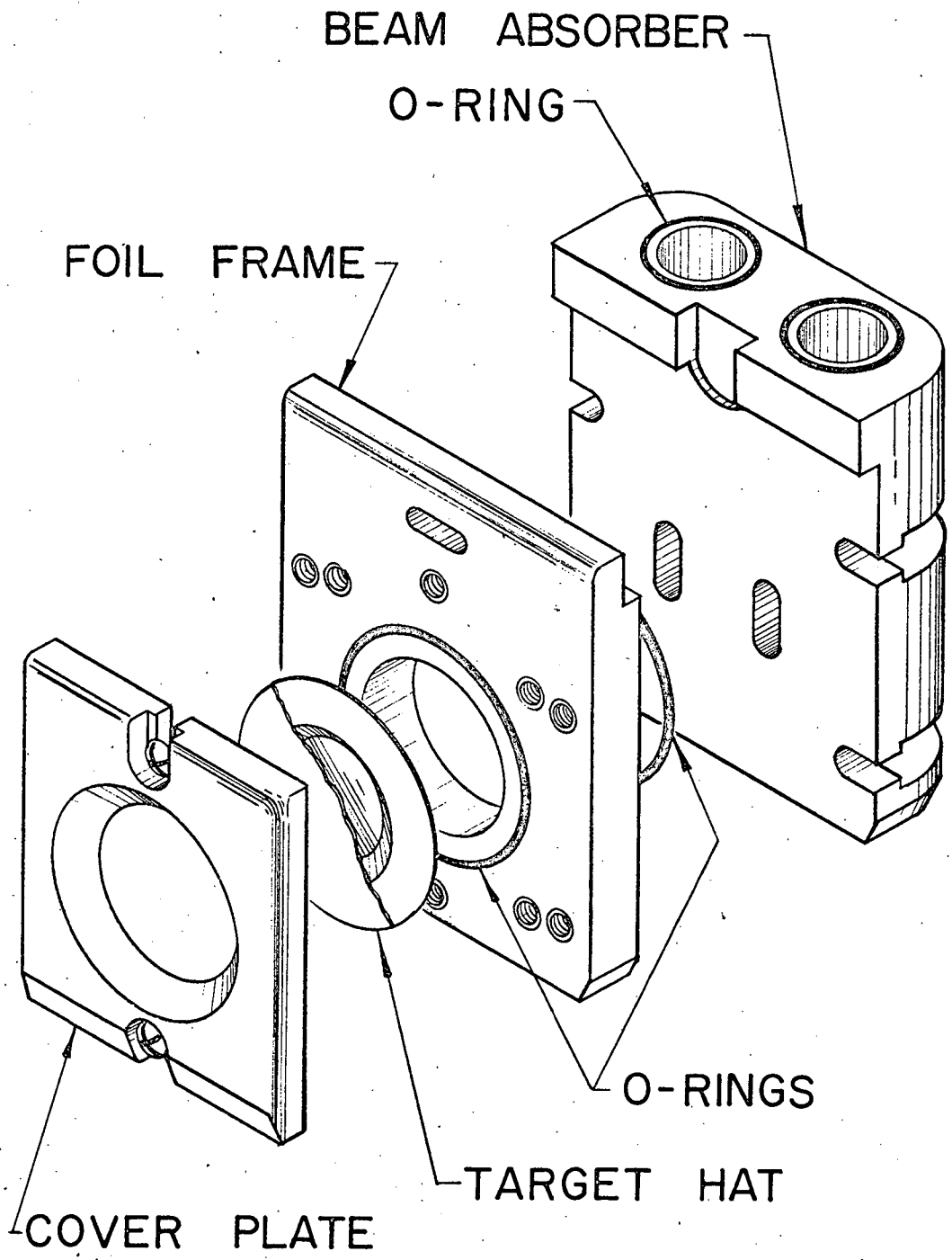

MUB-1211

Fig 3

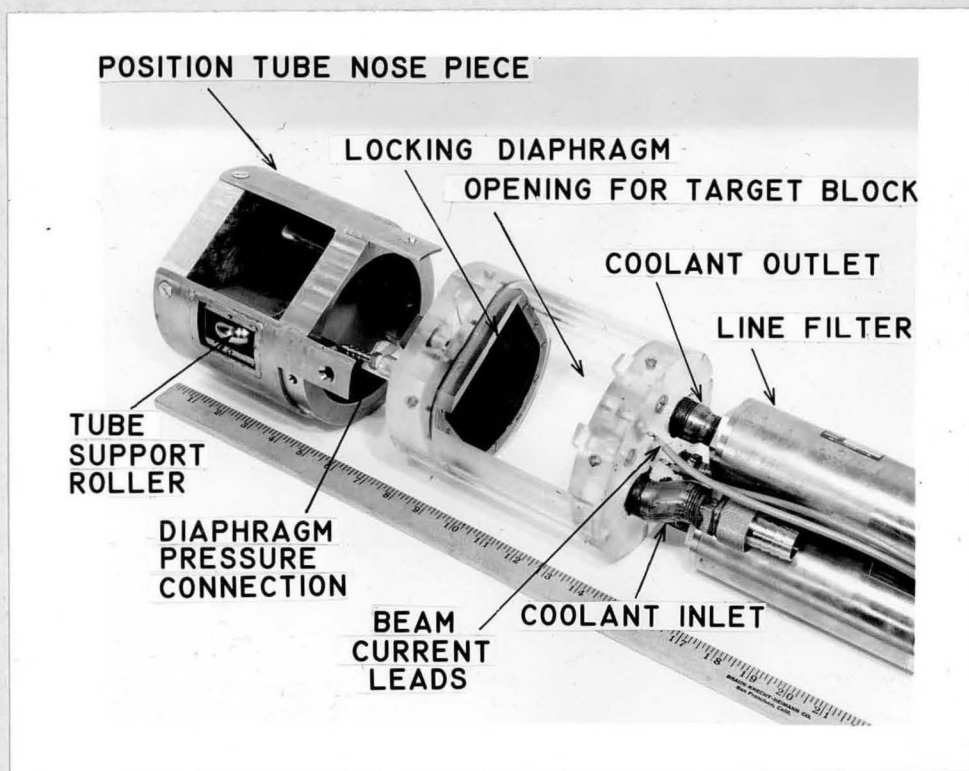

Fig. 4. Target block holder

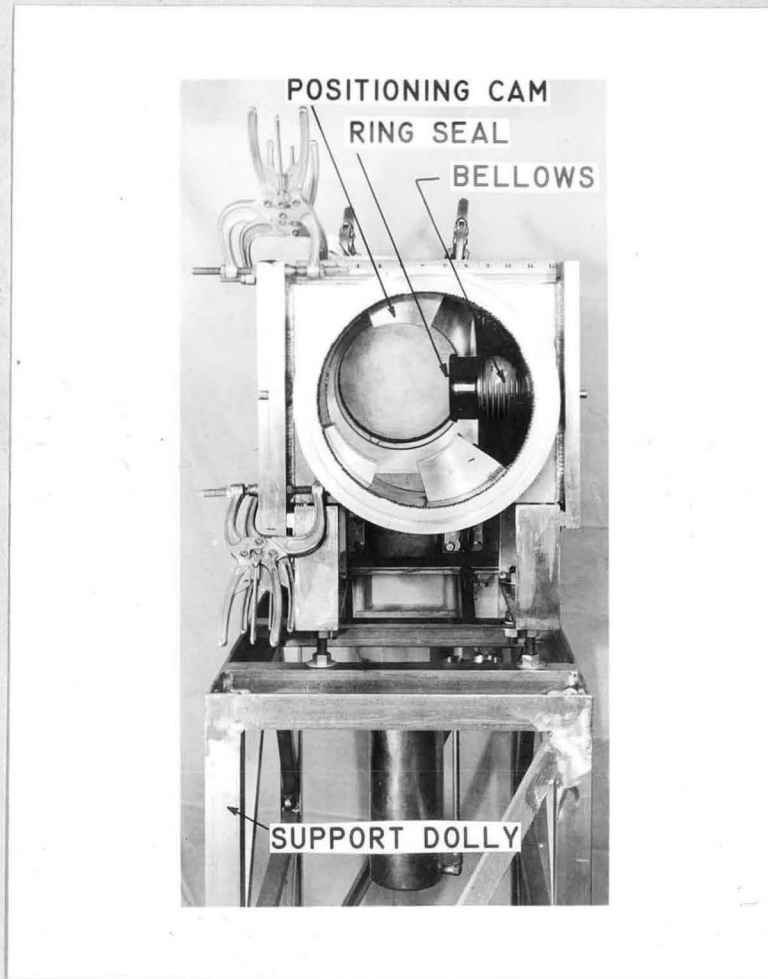

Fig. 5. Bombardment chamber - inspection end

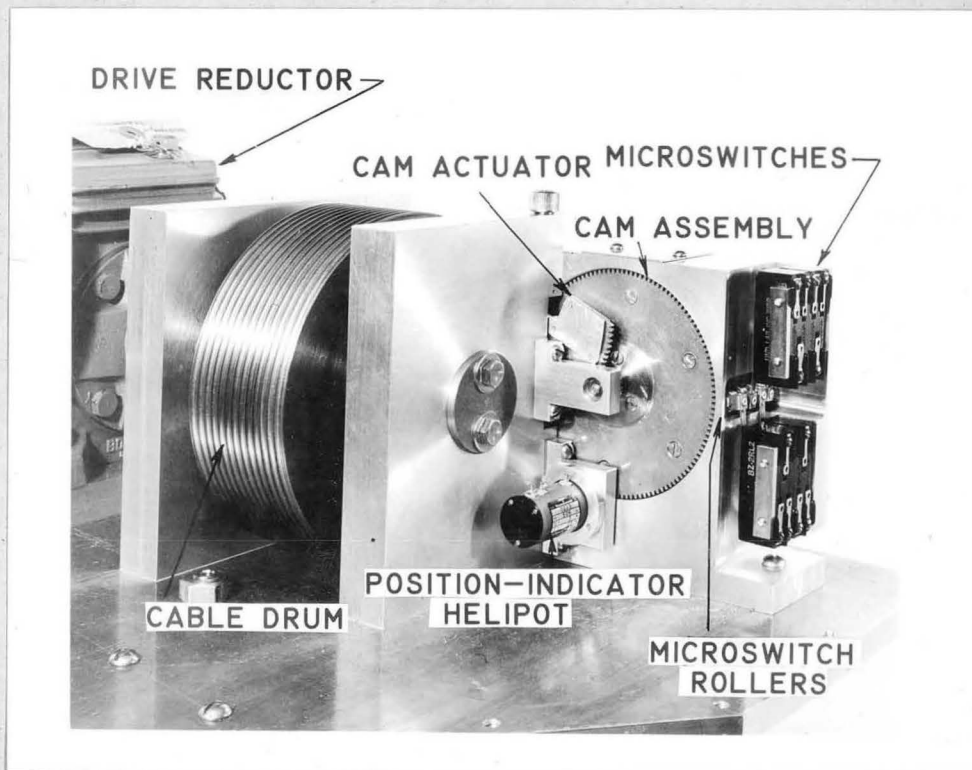

Fig. 6. Positioning tube drive

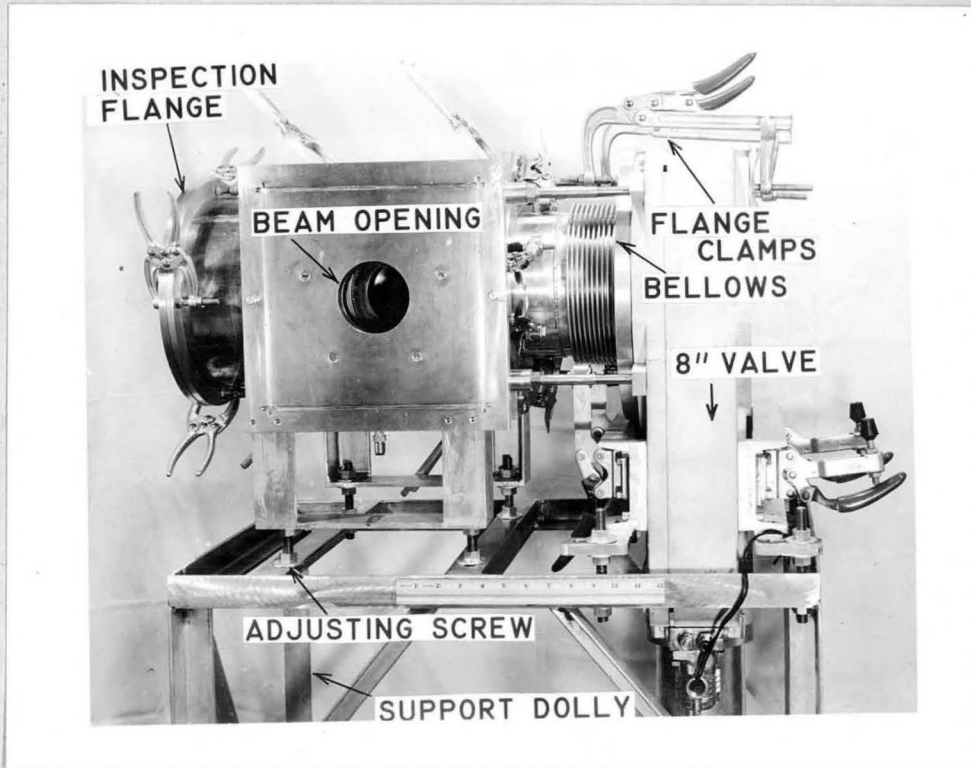
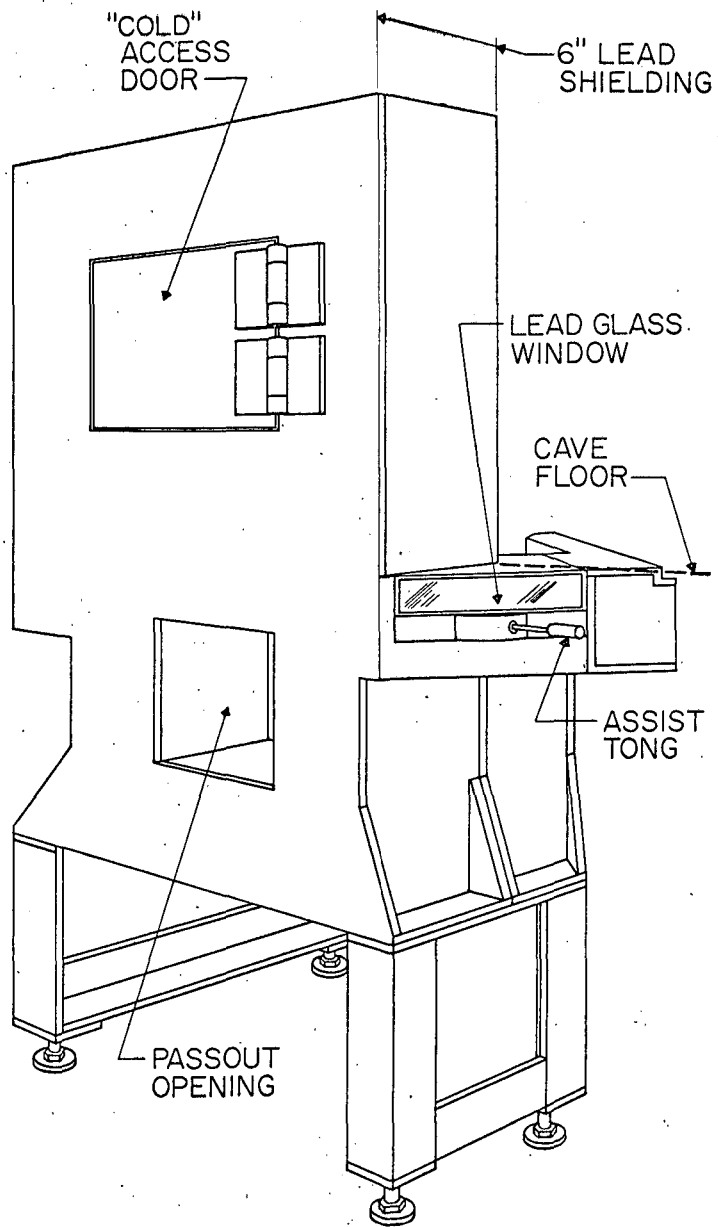

Fig. 7. Bombardment chamber - beam side



MUB-1209

Fig 8

Handwritten scribble or mark on the left margin.

