

# UC Berkeley

## UC Berkeley Previously Published Works

### Title

Quantitative evaluation of fracture processes in concrete using signal-based acoustic emission techniques

### Permalink

<https://escholarship.org/uc/item/9vt5z8vt>

### Journal

Cement & Concrete Composites, 28(4)

### ISSN

0958-9465

### Authors

Grosse, Christian U  
Finck, F

### Publication Date

2006-04-01

Peer reviewed

# Quantitative Evaluation of Fracture Processes in Concrete Using Signal-Based Acoustic Emission Techniques

Christian U. Grosse<sup>1+2</sup>, Florian Finck<sup>2</sup>

## ABSTRACT

Acoustic emission (AE) techniques can be used for the investigation of local damage in materials. Compared to other observation techniques one advantage is the recording of the damage process during the entire load history without any disturbance to the specimen. This is somehow unique and permits for high-resolution studies of the time dependent failure of materials including precise determinations of the beginning of fractures and their consecutive progression. There are only a few other experimental techniques in fracture mechanics allowing for similar detailed observations of materials' time and spatial behaviour. Moreover, these techniques allow a calibration of experiment and simulation comparing for example the output of Finite Element Modelling with AE data analysis. This paper deals with some experimental results obtained during fracture mechanical experiments at concrete specimens demonstrating the capabilities of quantitative AE techniques.

**Key Words:** civil engineering, non-destructive testing, acoustic emission, moment tensor, localization, fracture mechanics

---

<sup>1</sup> Department of Civil and Environmental Engineering, University of California, 455 Davis Hall, Berkeley, CA 94720-1710, USA, Fax: +1-510-643-5264, [grosse@berkeley.edu](mailto:grosse@berkeley.edu)

<sup>2</sup> Institute of Construction Materials, University of Stuttgart, Pfaffenwaldring 4, 70550 Stuttgart, Germany, now at company Behr GmbH & Co. KG, Stuttgart, Germany

## **1. INTRODUCTION**

Acoustic emission techniques are usually disposed among the non-destructive testing methods since they allow passively the observation of crack growth or internal defects. However, there are fundamental differences between diverse ways to apply AE techniques due to historical developments in electronics and sensor technologies. *Quantitative* or *signal-based* acoustic emission techniques [1] differ generally from so-called *classical* or *parameter-based* AE techniques, where only parameters are recorded and not the signal itself is stored. Signal-based techniques allow for detailed fracture mechanical evaluations of brittle materials like concrete, if a proper setup and adequate instruments are chosen. Since these differences between the traditional parameter-based and newer signal-based techniques are described earlier [2, 3] we will focus to recent results in the following.

There are four different steps of a modern AE analysis consisting of (1) the analysis of mechanical data and the acoustic emission rate, (2) the localization of acoustic emissions, (3) the evaluation of the topography of the fracture plane, and (4) fracture mechanical studies based on moment tensors. Here, advances of the techniques addressed under (2)-(4) are described in more detail along with some examples of measurements to study different failure modes in concrete.

## **2. AE-TECHNIQUES AND LOCALIZATION OF FRACTURES**

AE is defined as the spontaneous release of localized strain energy in a stressed material resulting, for example, from micro-cracking and can be recorded by transducers (sensors) on the surface in analogue to earthquake recording. One of the advantages compared to other NDE techniques is the possibility to observe the time-dependent damage process during the entire load history. To do so, the application of signal-based methods requires reliable localization, i.e. the

determination of the source coordinates of the events. There are several different ways to localize AE events [3, 4, 5], whereas the algorithms, using the arrival times of the waves recorded at multiple sensors, are in use since many years. Picking a distinct onset time of a signal at different sensors according to the example shown in *Fig. 1*, one can calculate the minimum of the sum of squares of the deviations and calculate the source coordinates usually with proper accuracy [6, 7]. Besides of these basic techniques two main issues had to be handled prior to the application of signal-based techniques – one concerning the data evaluation and the other concerning hardware requirements.

### *2.1 Automatic onset time determination*

Damage and failure processes often generate several thousand events from one damage zone within a very short time interval, revealing a huge amount of data. With *parameter-based* AE techniques a fast but only rudimentary analysis can be performed even on-line. Concerning the analysis of *signal-based* AE data usually needs the interpretation by an expert manually processing the data including a time consuming picking of the signal onsets by hand. Although for very large data sets this is not applicable. Therefore, the application of automatic analysis methods, including data conversion, denoising, and localization by the use of an automatic onset determination, moment tensor inversion and other features like b-value determination or the use of magnitude-squared coherence functions, is indispensable. Regarding the onset time picking the technique presented by KURZ ET AL. [8] based on the *Akaike Information Criterion* (AIC) is therefore a significant step forward for the application of the described techniques. It produces reliable results for signal onsets, where the deviation compared to the manual picks varies between 2 % and 4 %. Usually, the localization of only the 10 % of the events results in a mislocation vector greater than 5 mm.

## 2.2 Fast transient recorder

The acquisition of acoustic emission data requires transient recorder hardware, which is able to make A/D-conversion with a high resolution and simultaneously guarantees fast storage of signals. Conventional transient recorders have a limited performance (rate of signals per second) due to signal storing, which causes gaps in the data recording. Furthermore, a simple threshold trigger, which is standard in commercial recorders, is not able to identify acoustic emissions when the signal to noise ratio is poor. Therefore, the gradient of the signal is a much better indicator using a *slew rate* trigger. This motivated the development of an own transient recorder system. The new system enables continuous recording with up to 8 Channels, a sampling frequency of 1.25 MHz (up to 5 MHz) and an amplitude resolution of about 12 bit. One improvement is the absolute continuous recording, i. e. all acoustic emissions are recorded without any loss. Recordings are only limited by the hard disk capacity, where the continuous data stream is written on. After the recording the events are cut out using arbitrary and adjustable trigger conditions. This post-processing is controlled by the software package *TransOcto<sup>AE</sup>*, developed at the University of Stuttgart [9]. For experiments with lower acoustic emission activity this system can be used as a conventional transient recorder system as well.

## 3. INVERSION METHODS FOR FRACTURE ANALYSIS

To determine the fracture type and orientation of a rupture as well as the seismic moment, which describes the released energy, the waveforms of the recorded acoustic emission events can be interpreted using inversion methods. Using such an algorithm in combination with three-dimensional localization, the fracture process in the material can be evaluated comprehensively.

It was shown that the inversion to the moment tensor is an effective way to evaluate the physical parameters of fault processes not only in seismology [10] but also in material science [2]. In fact, there are different techniques to apply a moment tensor inversion (MTI). Among the suggested inversion schemes are simplified techniques [11, 12], full waveform [12], relative [13, 2] and hybrid methods [14]. A more detailed description about the differences can be found in Finck [15].

Fundamental differences seem to exist between the application of source models (Fig. 2, top) to the two scientific disciplines Seismology and Material Science. The classical model used to interpret earthquake data is a shear crack without a moment along a planar rupture surface. This fracture model is sufficient to explain most earthquake mechanisms. However, this simple model of a shear crack cannot describe more complex rupture phenomena, where opening of a crack and dilatational (or isotropic) components are present. The experimental work described in the following was done to study these effects more quantitatively.

For *mode 1* cracks, the incident particle motion is radial outwards, similar to an explosion. In the ideal (explosion) case the energy distribution is equal in all directions and the radiation pattern is not identical to that of a cleavage crack [16]. The collapse of a pore could be explained using an explosion model with negative sign, which means incident particle motion towards the hypocenter.

*Mode 2* and *mode 3* both are shear cracks with a progress of the tip of the crack parallel or perpendicular to the movement of sliding blocks, respectively. For *mode 2*, the rupture plane would be in the  $x$ -direction with the rear block moving to the right, which means an outwards particle motion on the right and inwards on the left. In material science most cracks cannot be described using only one of these fundamental mode types. Mixtures of the three mentioned models and other phenomena are necessary to explain the whole failure process.

The forward problem of the propagation of elastic waves in a brittle medium is formulated in detail in AKI & RICHARDS [17]. Typically, a certain source function generates an elastic wave that propagates through a medium and is affected by attenuation, dispersion, reflection, refraction and more. To measure these waves, different types of sensors can be attached on the surface of the specimen. Every sensor itself has a certain transfer function yielding a filtered electric signal which can be recorded. To gain information about the source, the recorded data have to be inverted. Solving the inverse problem with commonly used inversion methods, the Green's functions of the specimen, describing the wave propagation in a medium, and the transfer function of the recording system have to be known or eliminated. A unique Green's function is difficult to find for concrete specimen because of the heterogeneity of the medium. Consequently, a moment tensor inversion based on P-wave amplitudes was employed in a relative way to eliminate the influences of inhomogeneity and anisotropy by DAHM [13]. The method was developed for the determination of the radiation pattern using cluster analysis. This relative approach was tested for the requirements in AE experiments [2]. It works well as long as the source functions of the events in the respective cluster are not very similar. Under several assumptions they can then be calculated from their relative amplitude distributions. A hybrid inversion method developed by ANDERSEN [14] combines the absolute with the relative MTI enhancing the stability of the results significantly. The hybrid MTI method was used to analyze the data addressed in the following.

#### **4. FRACTURE MECHANICAL EXPERIMENTS AND INVERSION**

The new potential enabled by signal-based AE techniques was tested during a comprehensive series of fracture mechanical experiments. It was the intention to evaluate the reliability of the

methods during experiments designed to cause certain failure mechanisms in concrete. In the beginning it was not clear if the used models and assumptions produce artifacts instead of giving a valid picture of the internal failure. A splitting test according to DIN 1048-5 (*Brazilian test*) was carried out to study the occurrence of tensile cracks. Pull-out experiments were supposed to cause mainly shear cracks as well as a double edge notched compression test designed to “produce” a zoo of different fracture types (*Fig. 2*) in defined regions of the specimen.

#### *4.1 Splitting test (Brazilian test)*

To generate controlled tensile failure, a splitting test according to DIN 1048-5 [18] using an unreinforced concrete cube (edge length 200 mm) was performed. Compressive load was applied using two parallel steel edges, one on the top and the other on the bottom of the specimen (*Fig. 3, left*). Applying a load to the steel edges causes tensile cracks parallel to the edges. A controlled opening of the tensile cracks is necessary to obtain as many acoustic emissions during the evolution of the crack as possible and to enhance the significance of the AE analysis. Therefore, the crack opening was measured by two linear displacement sensors (LVDT), one on each side of the cube. The mean crack opening acted as the control parameter for the loading device.

Acoustic emissions were registered by eight piezo-electric ultrasonic sensors and recorded by the described transient recorder. Additionally, piston displacement, load and crack opening were recorded. Results of the mechanical test data and the acoustic emission rate over the test period are published in FINCK et al. [19] and REINHARDT ET AL. [20]. An overview of the results of the moment tensor inversion is presented in the form of the radiation patterns in stereographic projections (*Fig. 3, right*) analogue to the representation of fault mechanisms in *Fig. 2, bottom*. The decomposition of the moment tensors is revealing the percentile contributions of isotropic, double couple and CLVD mechanisms. Significant positive isotropic components and a mixture



of double couple and CLVD mechanisms are evident. Subsequent to the experiment, the specimen was ground in a stepwise manner, to digitize the run of the crack through the various sections. Thereby, the topography of the crack could be evaluated. The results of the localization of the acoustic emissions (black dots) and the inner crack surface (reticule) are plotted in *Fig. 3, right*. As a result, the radiation pattern of both events is plotted as concentric spheres around the epicenter. Tension (dark) is dominant in the source representation being more or less parallel to the y-axis and therefore parallel to the mean tensile stress and perpendicular to the load direction. A small compressive component almost parallel to the z-axis is indicated by negative amplitudes (light colored).

The results corroborate the assumption of *mode I* failure with a major tensile crack parallel to the steel edges from which load was applied. The mean tensile stress axis is parallel to the y-axis, which is also the preferred direction of positive amplitudes. The investigations reveal tensile fracturing as the dominant cause of failure. However, variations of the tension axes and deviations from pure tensile failure are observed. Inhomogenities, such as aggregates, generate undulations of the crack surface and can be responsible for an enhanced complexity of micro cracking. Corresponding shear stresses would explain the significant double couple components.

#### *4.2 Pull-out test*

The role of the bond between steel reinforcement and concrete matrix was investigated with signal-based AE techniques in a pull-out test. A steel bar ( $\varnothing$  15.6 mm) with five ribs (*Fig.4, left*) was pulled out of a concrete cube (edge length 200 mm). It was expected that Double-couple mechanisms are dominant due to the shear stress between matrix and reinforcement. Earlier experiments showed [2] that AE events close to the steel-concrete interface have fault planes

parallel to the bar while several events occur some distance away from the bar with fault planes up to 30° shifted but still parallel to the stress field in this region.

During these new experiments numerous acoustic emissions were localized [21] in the zone, where the ribs provided bond between the concrete matrix and the steel reinforcement again (*Fig.4, right*). Moment tensors were calculated for some selected events using the relative inversion approach by DAHM [13]. The solutions of these inversions yielded stable results with nearly 100 % double couple mechanisms. For each event one of the nodal planes was found to be oriented tangential to the steel bar boundary. The radiation patterns of the moment tensors indicate the downwards motion (dark grey, negative amplitudes) of the bar relative to the concrete block (light grey, positive amplitudes). This is in good agreement to the hypothesis.

#### *4.3 Compression test*

A double edge notched compression test (DENCT) was suggested by REINHARDT & XU [22] to study the critical failure energy  $K_{IIC}$  of brittle or quasi-brittle materials under shear stress. The experimental setup uses a one-sided bearing of an unreinforced cubic concrete specimen. *Mode 2* fractures are supposed to occur parallel to the load (*Fig. 5, left*), while the unstressed region is potentially subjected to a *mode 1* crack. Prior to the experimental work a numerical simulation of material failure done by Xu (*Fig. 5, right*) was used to predict the failure process [15] showing that the final failure will be due to compression in the loaded zone.

During the experiment the visual occurrence of cracks was compared to the AE data showing that small cracks initially started at the transition zone between loaded and unloaded regions separately at the top and the bottom part (zone A, B in *Fig. 5, left*). At the same time, a horizontal crack developed in the tension region (zone C) traveling into the specimen. AE data give a clear picture of the subsequent convergence of the cracks in zone A and B. During the final stage of the

experiment, damages in zone D caused by compression load became critical and lead to the failure of the specimen. *Fig. 6* gives a comprehensive view of the development of AE activity during this experiment, which is in good agreement with the crack distribution visually obtained during the experiment. A remarkable agreement can also be noticed to the predicted failure simulated numerically (*Fig. 5, right*). This encouraged inverting the data of two AE clusters (indicated in *Fig.6* as C1 and C2) onto the moment tensor, what was done by FINCK [15].

As expected the MTI provide evidence of the tension crack hypothesis for the cracks occurred in region C1. Besides, a quantitative statement has to take into account some ambiguities, because pure tension cracks are not properly covered by the used fault models in the inversion scheme [3, 19]. As stated above, events in cluster C2 were believed to be caused by pure shear cracks. Since the occurrence of shear failure in concrete is controversially discussed in the literature, AE events in this region were investigated with special attention. However, the picture is here not completely coherent with the shear hypothesis, since the isotropic components of these events are still high.

## **5. CONCLUSIONS AND OUTLOOK**

The described signal-based AE methods enable techniques, which are valuable tools for the analysis of fatigue and failure in materials. Some of the advantages are the possibility of continuous monitoring of damage growth in non-transparent materials and the determination of fracture type, size, energy and orientation. The localization of AE events due to cracking in concrete is done automatically and with appropriate accuracy due to the homogeneity and isotropy of the material.

Several fracture mechanical experiments were conducted to study the failure of concrete. For the very first time, the analysis of AE data supported by reliable moment tensor inversions enables

for high-resolution damage analysis. Three different scenarios were investigated. A *Brazilian test* caused failure due to tension and thus tensile cracks are dominant in the MTI analysis. Experiments pulling reinforcement bars out of a concrete cube showed *Double-couple* mechanisms to be the origin of the generated failure process. This is, however, not a proof of the shear fracture hypothesis in concrete, since most of the analyzed events had a location next to the steel-concrete interface being therefore located at a pre-existing fault zone. The failure mechanisms should be addressed rather to be friction in this case.

Finally, an experiment suggested by REINHARDT & XU [22] was conducted, whereby regions of “pure shear stress” were expected to exist. The AE data are giving more evidence here to the scepticism regarding the existence of shear in concrete, because *mode I* components are not negligible in the data. Therefore, theories to favour stick-slip models with more or less small tensile components to cause an initial failure followed by en-echelon cracks [23] and friction [24] will be evaluated in more detail using the experimental methods described in this paper and in GLASER & JOHNSON [25].

## **ACKNOWLEDGEMENTS**

The authors are indebted to Prof. Hans-Wolf Reinhardt, University of Stuttgart, and Prof. Steven D. Glaser, University of California, Berkeley, for numerous stimulations. The numerical simulation of one of the experiments was conducted by Prof. Shilang Xu. Contributions of Jochen H. Kurz regarding the data analysis and of Gerhard Bahr and Markus Schmidt regarding the experimental work are gratefully acknowledged. A part of this research was supported by the Deutsche Forschungsgemeinschaft (DFG) via grant GR1664/2.

## REFERENCES

- [1] Ouyang C, Landis E, Shah SP. "Damage Assessment in Concrete using Quantitative AE," *J. Engineering Mechanics*, Vol. 117, No. 11, ASCE, 1991, 2681-2698.
- [2] Grosse CU, Reinhardt HW, Dahm T. Localization and classification of fracture types in concrete with quantitative acoustic emission measurement techniques. *NDT&E Int.* 1997; 30: 223-230.
- [3] Grosse CU, Reinhardt HW, Finck F. Signal-based acoustic emission techniques in civil engineering. *J. of Mat. Civ. Eng.* 2003; 15(3): 274-279.
- [4] Berthelot JM, Robert JL. Modeling concrete damage by acoustic emission. *J. of Ac. Emission* 1987; 6 (1): 43-60.
- [5] Labuz JF, Chang HS, Dowding CH, Shah SP. Parametric study of AE location using only four sensors". *Rock mechanics and rock engineering* 1988; 21: 139-148.
- [6] Grosse CU, Reinhardt HW. Entwicklung eines Algorithmus zur automatischen Lokalisierung von Schallemissionsquellen. *Die Materialprüfung* 1999; 41: 342-347.
- [7] Köppel S, Grosse CU. Advanced acoustic emission techniques for failure analysis in concrete. Proc. of 15. World Conf. on Non-Destructive Testing (WCNDT), Rome, 2000, on CD-ROM, <<http://www.ndt.net/article/wcndt00/papers/idn231/idn231.htm>>.
- [8] Kurz JH, Grosse CU, Reinhardt HW. Strategies for reliable automatic onset time picking of acoustic emissions and of ultrasound signals in concrete. *Ultrasonics* 2005; 43: 538-546.
- [9] Grosse CU, Finck F, Kurz JH, Reinhardt HW. Improvements of AE technique using wavelet algorithms, coherence functions and automatic data analysis techniques. *J. of Constr. and Build. Mat.* 2004; 18 (3): 203-213.
- [10] Dahlen FA, Tromp J. *Theoretical Global Seismology*. Princeton, New Jersey: Princeton University Press, 1998.
- [11] Ohtsu M, Okamoto T, Yuyama S. Moment Tensor Analysis of AE for Cracking Mechanisms in Concrete. *ACI Structural Journal*, Vol. 95, No. 2, 1998, 87-95.
- [12] To AC, Glaser SD. Full waveform inversion of a 3-D source inside an artificial rock *J. of Sound and Vibration* 2005; 285 (4-5): 835-857.
- [13] Dahm T. Relative moment tensor inversion based on ray theory: theory and synthetic tests. *Geophys. J. Int.* 1996; 124: 245-257.
- [14] Andersen LM. A relative moment tensor inversion technique applied to seismicity induced by mining. PhD thesis, University of Witwatersrand, Johannesburg, South Africa, 2001.

- [15] Finck F. Untersuchung von Bruchprozessen in Beton mit Hilfe der Schallemissionsanalyse. PhD thesis, University of Stuttgart, Stuttgart, Germany, 2005.
- [16] Wadley HNG, Scruby CB. Elastic wave radiation from cleavage crack extension. *Int. J. Frac.* 1983; 23: 111-128.
- [17] Aki K, Richards PG. *Quantitative Seismology, Vol. 1.* Sausalito CA: University Science Books, 2002.
- [18] DIN 1048, part 5: Prüfverfahren für Beton – Festbeton, gesondert hergestellte Probekörper. Deutsches Institut für Normung e. V, 1991.
- [19] Finck F, Yamanouchi M, Reinhardt HW, Grosse CU. Evaluation of mode I failure of concrete in a splitting test using acoustic emission technique. *International J. of Fracture* 2003; 124: 139-152.
- [20] Reinhardt HW, Finck F, Grosse CU, Kurz JH. Brazilian test of concrete evaluated by AE. Ext. Abstract, International Conference on Fracture ICF-11, Turin 20-25 March 2005, (on CD-ROM).
- [21] Rosenbusch N. Entwicklung eines Programms zur Bestimmung von Ersteinsätzen und Amplituden sowie zur 3D-Lokalisierung von Schallemissionen. Diploma thesis, University of Stuttgart, Stuttgart, Germany, 2003.
- [22] Reinhardt HW, Xu S. Experimental determination of  $K_{IIc}$  of normal strength concrete. *Materials and Structures* 1998; 31: 296–302.
- [23] Eisbacher GH. *Einführung in die Tektonik.* Stuttgart: Enke Verlag, 2. Edition., 1996: 374 p.
- [24] Dieterich JH. Time-dependent friction and the mechanics of stick-slip. *Pageoph* 1978; 116: 790-806.
- [25] Glaser SD, Johnson LR. Multi-scale experimental investigation of sliding friction. NSF proposal. 2005, 19 p.

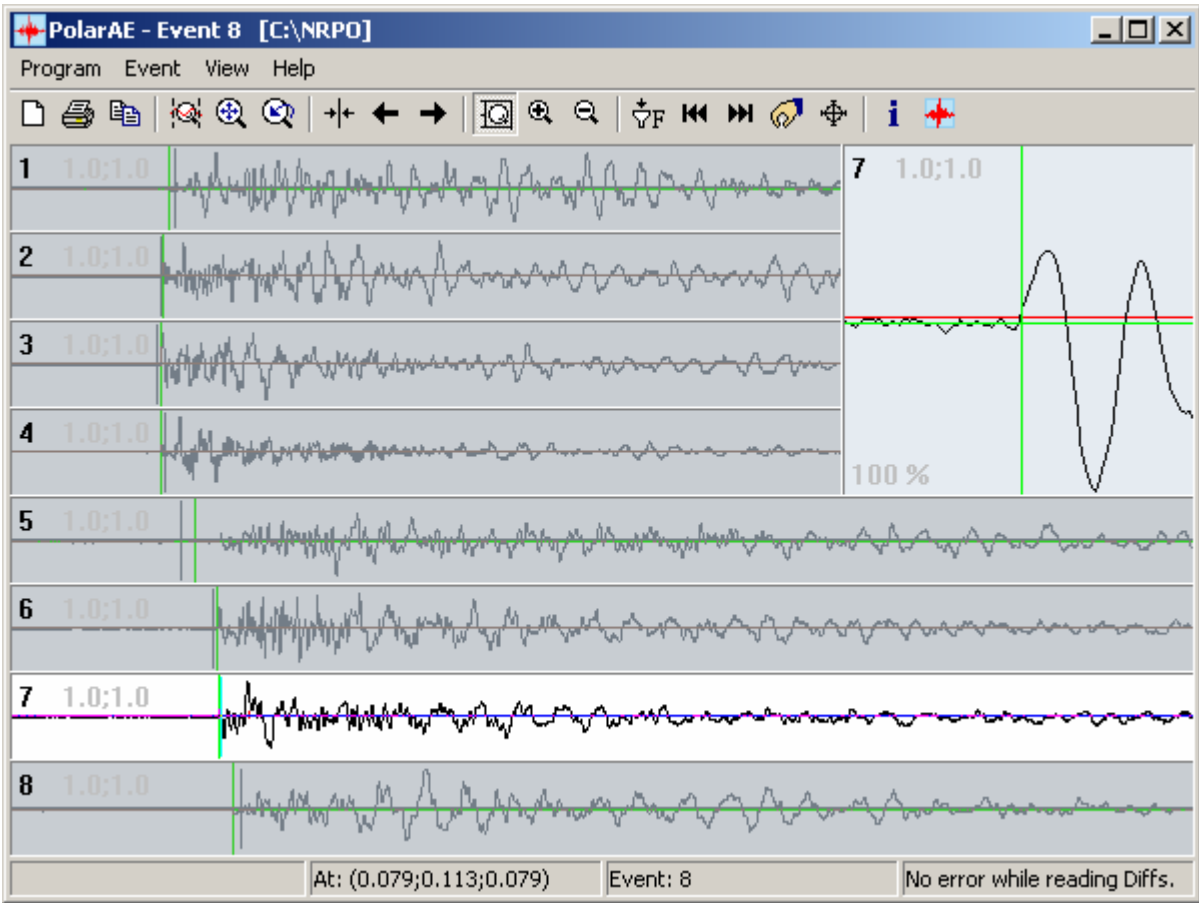

Fig.1

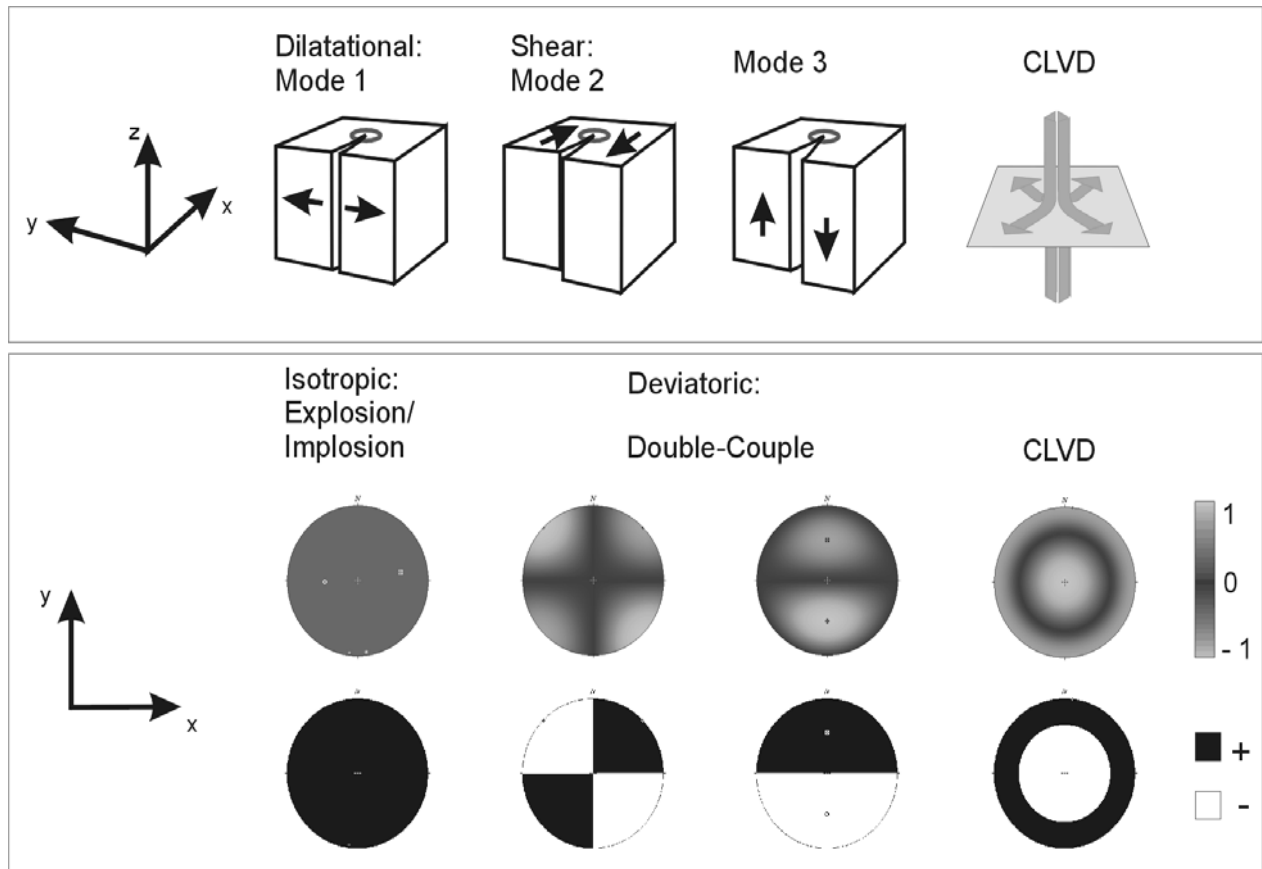

Fig.2



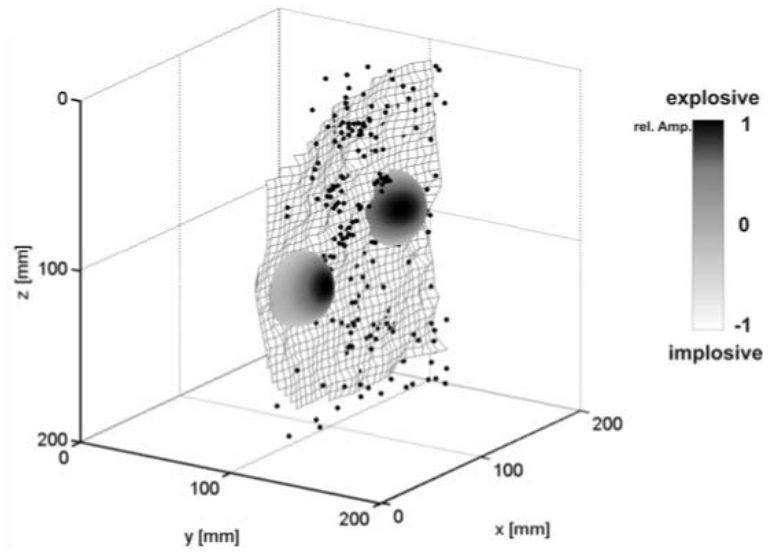
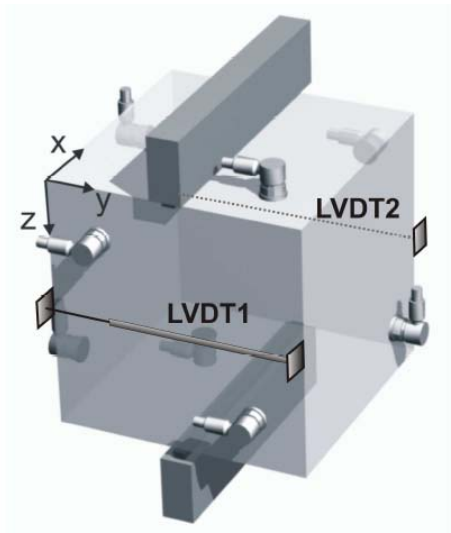

Fig.3

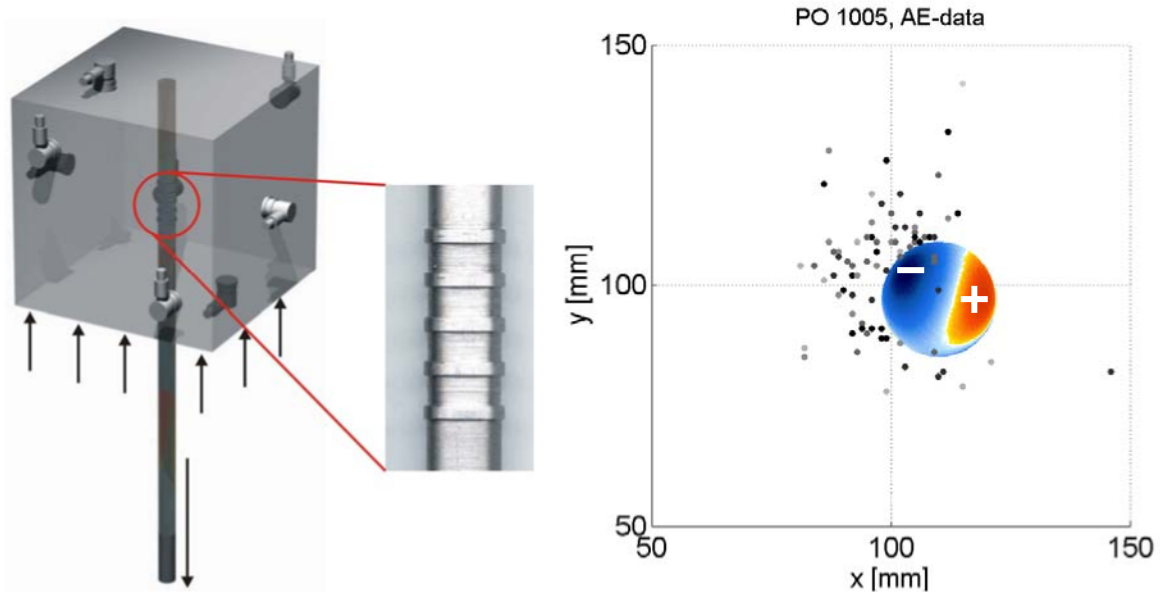

Fig.4

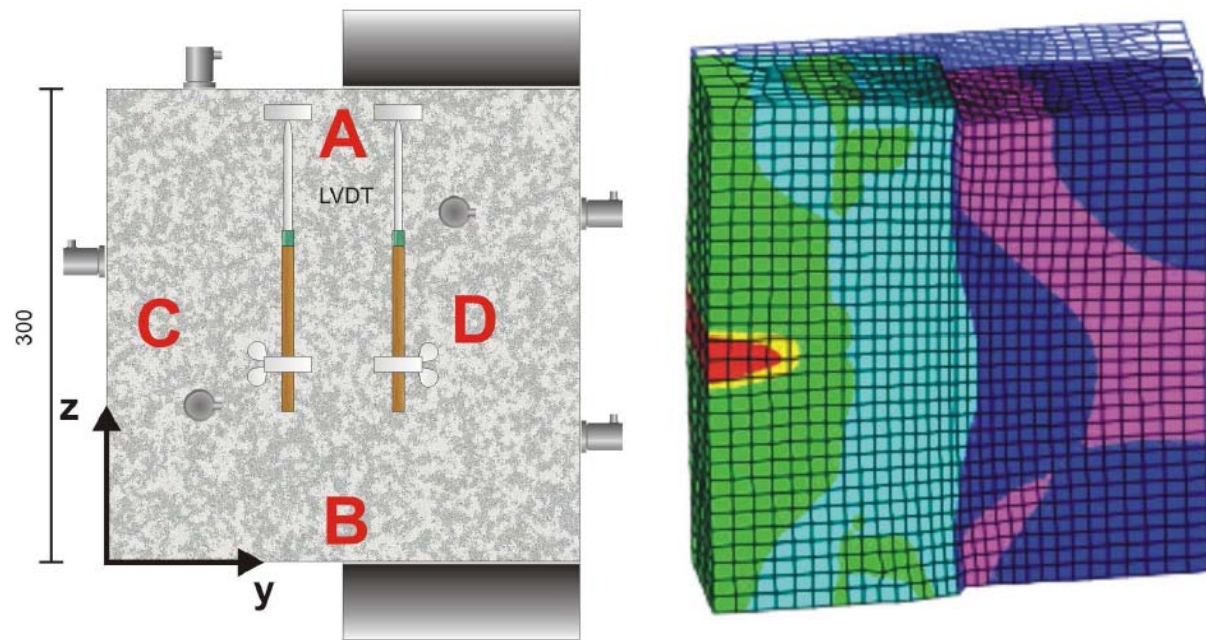
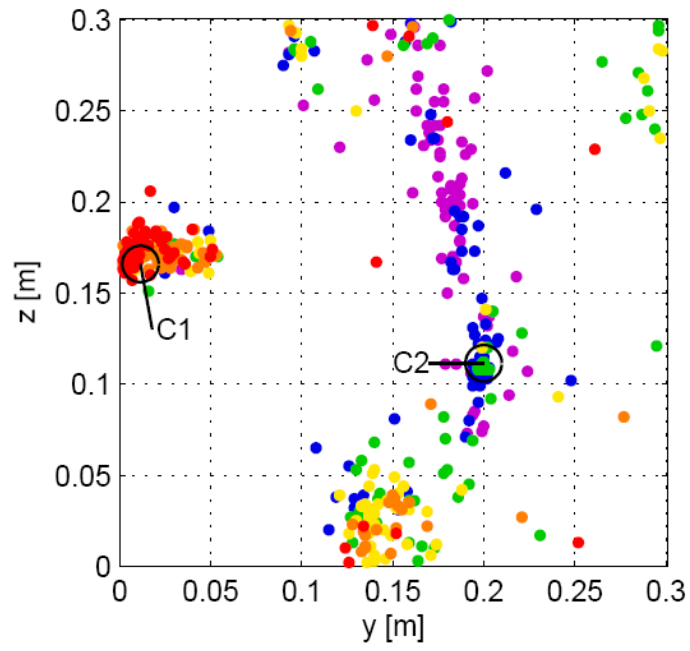

Fig.5



*Fig.6*

### Figure captions:

Fig. 1. Example of the arrival time extraction for the 3D localization of acoustic emissions using the *Polar<sup>AE</sup>* software developed at the University of Stuttgart [21].

Fig. 2. Comparison of radiation patterns of an opening crack (*mode 1*), shear cracks (*mode 2* and *3*), and the compensated linear vector dipole (CLVD). On top an illustration of the rupture zone, in the middle the distribution of the amplitudes (isotropic and deviatoric mechanisms) in a greyscale and on bottom the incident polarities of the focal particle motion, both in a stereographic projection. For more explanations see FINCK et al. [19].

Fig. 3. Left: Setup of the splitting test. Right: The topography of the crack surface and the radiation patterns of selected events from the two clusters. Both radiation patterns reveal positive (dark) amplitudes parallel to the mean tensile stress and some negative (light grey) amplitudes parallel to the z-axis due to compressive stress. [19].

Fig. 4. Left: Setup of the pull-out test. Right: Localization of acoustic emissions, which occurred during the pull-out of a ribbed steel bar out of a concrete cube. The solution of the moment tensor inversion illustrates the pull-out of the bar, with a downwards motion relative to the concrete cube [15].

Fig. 5. Left: Setup of the DENCT experiments at an unreinforced concrete cube; damage zones A-D according to the text. Right: FE simulation of the DENCT tests.

Fig. 6. Distribution of AE events with concentration in zone A-D (Fig.5, left). Two clusters (C1, C2) are accentuated with predicted dominant tensile or shear stress, respectively.