

Lawrence Berkeley National Laboratory

Lawrence Berkeley National Laboratory

Title

Long Plasma Source for Heavy Ion Beam Charge Neutralization

Permalink

<https://escholarship.org/uc/item/9w96081z>

Author

Efthimion, P.C.

Publication Date

2009-03-13

Long Plasma Source for Heavy Ion Beam Charge Neutralization

**P.C. Efthimion, E.P. Gilson, L. Grisham, R.C. Davidson, PPPL
B.G. Logan, P.A. Seidl, W. Waldron, LBNL**

Accelerator Fusion Research Division
Ernest Orlando Lawrence Berkeley National Laboratory
University of California
Berkeley, California 94720

June 2008

Long Plasma Source for Heavy Ion Beam Charge Neutralization

Philip. C. Efthimion^a, Erik P. Gilson^a, Larry Grisham^a, Ronald C. Davidson, Larry, B. Grant Logan^b, Peter A. Seidl^b, and William Waldron^b

^a Plasma Physics Laboratory, Princeton University, Princeton, NJ, 08543 USA

^b Lawrence Berkeley National Laboratory, University of California, Berkeley, CA, 94720 USA

Abstract

Plasmas are a source of unbound electrons for charge neutralizing intense heavy ion beams to focus them to a small spot size and compress their axial length. The plasma source should operate at low neutral pressures and without strong externally-applied fields. To produce long plasma columns, sources based upon ferroelectric ceramics with large dielectric coefficients have been developed. The source utilizes the ferroelectric ceramic BaTiO₃ to form metal plasma. The drift tube inner surface of the Neutralized Drift Compression Experiment (NDCX) is covered with ceramic material. High voltage (~ 8 kV) is applied between the drift tube and the front surface of the ceramics. A BaTiO₃ source comprised of five 20-cm-long sources has been tested and characterized, producing relatively uniform plasma in the 5×10^{10} cm⁻³ density range. The source was integrated into the NDCX device for charge neutralization and beam compression experiments, and yielded current compression ratios ~ 120. Present research is developing multi-meter-long and higher density sources to support beam compression experiments for high energy density physics applications.

Keywords: Plasma source; Neutralized transport, Beam neutralization

Corresponding author. Tel.: 609-243-3212; email: pefthimion@pppl.gov

1. Introduction

Heavy ion fusion and high energy density physics applications utilize space-charge-dominated beams that need to be longitudinally and radially compressed to achieve the high beam intensities required at the target [1,2]. Longitudinal compression increases the beam current and reduces the size and cost of heavy ion drivers needed for these applications. Previously, the Neutralized Transport Experiment (NTX) demonstrated transverse focusing beyond the space-charge limit by space-charge neutralizing the ion beam with background plasma [3]. Recently, the Neutralized Drift Compression Experiment

(NDCX) demonstrated that an ion beam with axial velocity tilt could achieve longitudinal current compression ratios of approximately 50 when the beam passed through background plasma [4]. In this longitudinal compression experiment, plasma was transported from a cathodic arc source to a meter distance upstream using a solenoidal magnetic field. Here we present the development and characterization of a one-meter-long Ferroelectric Plasma Source (FEPS) and also the fabrication of a multi-meter-long FEPS. The one-meter-long FEPS has been incorporated in the longitudinal compression experiments on NDCX. This source is a linear scaling of the FEPS that achieved charge neutralization and transverse focusing of ion beams on the NTX device.

2. Ferroelectric Plasma Source

Ferroelectric materials have been intensively examined as high current density electron emitters [5-7]. They have been projected to serve as large-surface-area, high-current-density cathodes. A mesh-like electrode structure is mounted to the emitting side of the ferroelectric material and the back surface has a metal plate electrode. A 3-15 kV potential is applied to the electrodes depending upon the thickness of the ferroelectric material. For ultra-thin-film ferroelectric materials, the applied voltage results in spontaneous polarization reversal on a nanosecond timescale, and a high electric field. Spontaneous polarization reversal yields a noncompensated charge at the surface and a high electron emission across the entire thin film.

For millimeter-thick ferroelectrics, the electric fields are too small to produce polarization reversal. However, plasma emission is observed and is produced by electron emission from the vacuum micro-gaps between the dielectric surface and the edge of the metal electrode surface [8]. For this configuration, the value of the dielectric constant is the key

factor. Commonly used ferroelectric materials have extremely large dielectric constants: BaTiO_3 has a dielectric constant in the range of 1000-3000, and $\text{Pb}(\text{Zr,Ti})\text{O}_3$ (PZT) has a dielectric constant in the range of 3000-6000. Once the threshold voltage is reached, plasma is formed over the entire surface of the dielectric. Typical current density yields are 0.5 A/cm^2 . Plasma emission from these dielectrics has been characterized [8]. Typically, 8 - 16 kV, 0.25 μs pulses are applied to the electrodes at operating pressures near 10^{-5} Torr. The fact that the plasma is essentially all metal means that neutrals adhere to the walls of the vacuum system and do not result in a pressure rise.

The characteristics of this plasma source are exactly what are required for the charge neutralization experiments on NTX and the beam compression experiments on NDCX. Furthermore, the ability to make the plasma-emitting layer arbitrarily long is important. The source is mounted on the walls of the drift tube just past the last focusing magnet. The drift tube is approximately 3 inches in diameter. This small tube diameter allows the density to be in the 10^{10} - 10^{12} cm^{-3} range on axis. The approach taken is to build a source with cylindrical ferroelectric pieces stacked together to form a one-meter-long ferroelectric cylinder. A cylindrical ferroelectric segment used as the building block of the long plasma sources is shown in Fig. 1.

The power supply for this pulsed source is a standard capacitor bank with a pulse-forming network to match the impedance of the source and maintain the microsecond pulse shape. As presently configured the pulse-forming network is matched to 4 ohms and has a maximum output of 8 kV and 2 kA. Thyratrons control the discharge of the charging capacitors. The output of the power supply is two 1-microsecond pulses with an adjustable time delay between the pulses. The plasma conditions can be controlled by adjusting either the applied high voltage or the delay when the ion beam passes through the plasma. With the ion beam pulse only 1 μs long, it is easy to control the plasma conditions by adjusting the time when the beam pulse passes through the plasma.

Fabrication and Characterization of the one-meter-long FEPS

Results from the prototype PZT prototype FEPS were sufficient to proceed with the design and building of the one-meter-long FEPS for NDCX. It was fabricated with BaTiO_3 ceramic instead of the PZT ceramic because the PZT ceramic ablated into a fine powder, and there was a concern for the hazard of the lead-based powder. A prototype 20-cm-long source did not work well with the thin wire electrodes used in the PZT source, and they were replaced by a steel mesh. The photograph in Fig. 1 of the cylindrical ferroelectric segment also shows the steel mesh on the inner surface of the segment. The mesh worked particularly well in producing plasma. The one-meter-long FEPS was

fabricated as five 20-cm sources separated by Delrin insulating rings with 1 inch holes to provide diagnostic ports along the plasma. Figure 2 shows a photograph of the entire FEPS assembled, including the diagnostic ports. During the fabrication and testing, a number of rings were damaged and the source length was reduced from 1 m to 85 cm.

Simply connecting the five sources in parallel to a single pulse-forming network power supply yielded non-uniform source performance due to the time-dependent nature of the load that each of the five plasma sources experienced. Furthermore, the first two sources fabricated were extensively tested compared to the remaining three.

Consequently, the first two sources required higher voltage than the remaining three to achieve the same nominal density of mid- 10^{10} cm⁻³. The power supply used for the earlier testing and described above provides two voltage pulses by two capacitor banks and pulse-forming networks charged with one voltage supply. With the variability in the five sources, the two banks and networks were electrically separated to independently charge the two groups of plasma sources. Each group of sources was connected in parallel across the outputs of each pulse-forming network. High-power resistors were added to the 3 newer sources to optimize the voltages applied to the sources to achieve densities in the mid- 10^{10} cm⁻³ range. The resistors were necessary since each group of sources was supplied with the same voltage. The density along the entire source in Fig. 2 is reasonably uniform. Further resistor optimization can improve the uniformity if necessary.

Neutralization Experiments on NDCX

The FEPS was shipped to LBNL and mounted into NDCX (Neutralized Drift Compression Experiment). NDCX has the ability to apply a velocity tilt to the beam pulse so the back of the beam pulse catches up to the front of the pulse to achieve longitudinal compression. Transverse compression is achieved with focusing magnets. Both compression schemes are applied simultaneously but will not succeed without beam charge neutralization.

Initial experiments were on transverse compression. The last focusing magnets direct the beam on a trajectory that focuses it to a spot size smaller than permitted by the space-charge limit. Before the beam approaches the space-charge limit, it enters the plasma created by the FEPS, where it accumulates electrons and charge-neutralizes. The neutralized beam continues on its focusing trajectory, does not diverge, and achieves an extremely small spot size. The spot size is on the order of 4 mm diameter and is smaller than achievable without charge neutralization. The measured current was twice that achieved when compression was applied with no plasma source (Fig. 3).

In the next experiments the velocity tilt was optimized for the FEPS. With both longitudinal and transverse compression applied the ferroelectric plasma source achieved a factor of 120-fold increase in peak current- somewhat better than previously achieved (Fig.4). There was also a reduction in the transverse spot size. However, when the FEPS was operated along with the MEVA plasma source, the longitudinal compression was not as good but the transverse spot size was smaller (Figs. 3 & 4).

New Source Development

Recently additional lengths of the FEPS have been fabricated for new compression experiments. A new 30 cm section will be added to the existing 85 cm source. It will be energized by the existing power supply. Furthermore, a new 5 section FEPS has been build with the diameter and the same ferroelectric material. It is 107 cm in length and has a power supply and distribution of energy to the five sections similar to the previous source. This brings the total length of plasma sources to 223 cm. They will be installed together in NDCX for a new series of compression experiments. The new capability will allow the velocity tilt to be more gradual and with the longer neutralizing plasma column the heavy ion beam can focus to a smaller diameter and less temporal and transverse aberrations than created in the previous experiments with stronger tilt and a shorter plasma column. All of the FEPS source sections are shown in a schematic of NDCX in Fig. 5.

Next generation sources will have to operate at densities an order of magnitude higher than the existing FEPS for future warm density matter experiments. Higher voltage and double-pulse operation will be examined to extend the density operating range of the source. Another technique is to reduce the diameter of the ferroelectric source by using ferroelectric cylindrical sections that are only 1.135" in diameter rather than the present 3.00" diameter cylindrical. Previous studies show that the fall off of density from the ferroelectric surface is exponential and is an order of magnitude over 1 cm. A single small diameter source made with a single segment has been pulsed, but its density will be shortly measured. Eventually an additional source operating at four orders of magnitude higher density over a few mm will be needed for the warm dense matter experiments. Concepts for that source are being developed including ionizing a small diameter gas jet with a powerful pulsed excimer laser.

References

- [1] B. G. Logan and D. A. Callahan, Nucl. Instr. and Meth. In Phys. Research A 415 (1998) 468.
- [2] D. A. Callahan, Fusion Eng. Des. 32-33 (1996) 441.
- [3] P. K. Roy, S. Yu, et al., Phys. Plasmas 11 (2004) 2890.
- [4] P. K. Roy, et al., Phys. Rev. Lett. 95 (2005) 234801.
- [5] G. Rosenman, et al., Appl. Phys. Rev. 88 (2000) 6109.
- [6] A. Dunaevsky, et al., Journal of Applied Physics 95 (2004) 4621.
- [7] A. Dunaevsky, et al., Journal of Applied Physics 90 (2001) 3689.
- [8] A. Dunaevsky, et al., Journal of Applied Physics 89 (2001) 4.

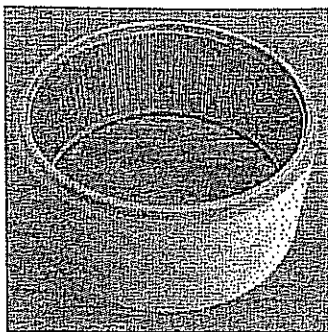

Figure 1: Photograph of the 1.6"-long BaTiO₃ ferroelectric source segment.

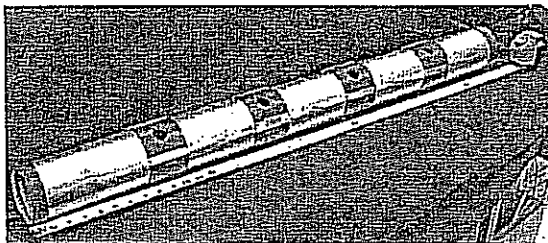

Figure 2 The one-meter-long BaTiO₃ FEPS consists of 5 individual sources with diagnostic ports between the sources.

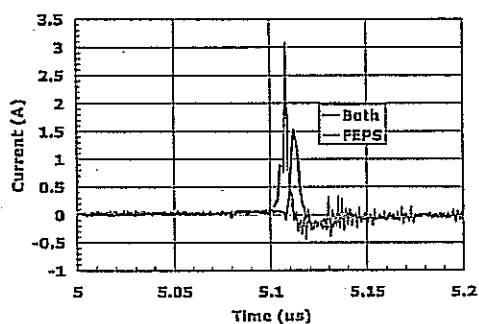

Figure 3: Time trace of the longitudinally compressed ion beam with charge neutralization with the FEPS and with both plasma sources.

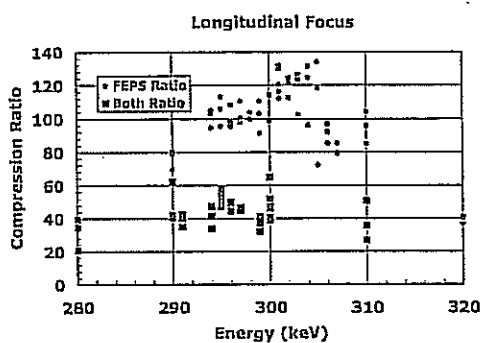

Figure 4: Longitudinal compression using the FEPS for charge neutralization yields a 120 compression.

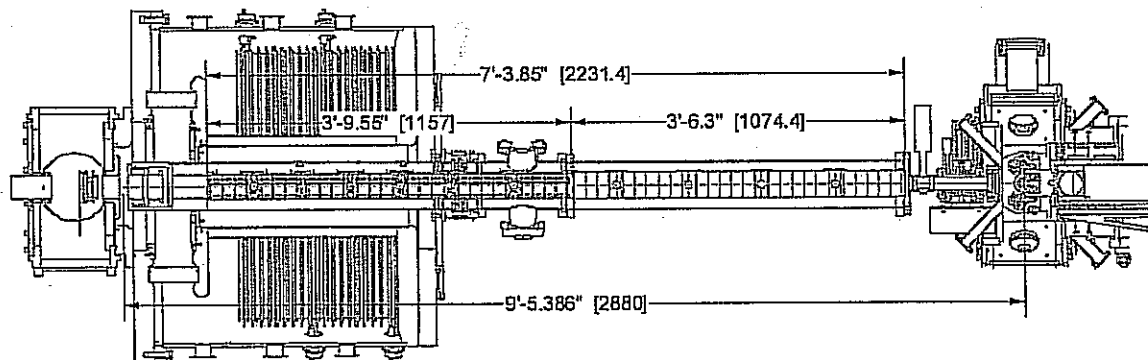

Fig. 5 Schematic of NDCX with all of the FEPS sections, totalling 223 cm, mounted in the drift tube. The longer plasma column along with a more gradual velocity tilt is expected to reduce temporal and spatial aberrations in compression experiments.