

Lawrence Berkeley National Laboratory

LBL Publications

Title

An Automatic Lithium Drifting Apparatus for Silicon and Germanium Detectors

Permalink

<https://escholarship.org/uc/item/9xm43683>

Authors

Goulding, Fred S

Hansen, W L

Publication Date

1964-02-01

Copyright Information

This work is made available under the terms of a Creative Commons Attribution License, available at <https://creativecommons.org/licenses/by/4.0/>

UCRL-11261

c.2

University of California Ernest O. Lawrence Radiation Laboratory

TWO-WEEK LOAN COPY

*This is a Library Circulating Copy
which may be borrowed for two weeks.
For a personal retention copy, call
Tech. Info. Division, Ext. 5545*

AN AUTOMATIC LITHIUM-DRIFTING APPARATUS
FOR ³¹SILICON AND GERMANIUM DETECTORS

Berkeley, California

UCRL-11261
c.2

DISCLAIMER

This document was prepared as an account of work sponsored by the United States Government. While this document is believed to contain correct information, neither the United States Government nor any agency thereof, nor the Regents of the University of California, nor any of their employees, makes any warranty, express or implied, or assumes any legal responsibility for the accuracy, completeness, or usefulness of any information, apparatus, product, or process disclosed, or represents that its use would not infringe privately owned rights. Reference herein to any specific commercial product, process, or service by its trade name, trademark, manufacturer, or otherwise, does not necessarily constitute or imply its endorsement, recommendation, or favoring by the United States Government or any agency thereof, or the Regents of the University of California. The views and opinions of authors expressed herein do not necessarily state or reflect those of the United States Government or any agency thereof or the Regents of the University of California.

Proceedings 9th Scintillation and
Semiconductor Counter Sympos
Symposium Wash. Feb. 26-28,
1964

UCRL-11261

UNIVERSITY OF CALIFORNIA
Lawrence Radiation Laboratory
Berkeley, California

AEC Contract No. W-7405-eng-48

AN AUTOMATIC LITHIUM DRIFTING APPARATUS
FOR SILICON AND GERMANIUM DETECTORS

Fred S. Goulding and W. L. Hansen

February 8, 1964

AN AUTOMATIC LITHIUM DRIFTING APPARATUS FOR SILICON AND GERMANIUM DETECTORS

Fred S. Goulding and W. L. Hansen

Lawrence Radiation Laboratory
University of California
Berkeley, California

Abstract

Drifting a thick lithium-drifted counter (silicon and germanium) is a time-consuming operation that frequently results in a poor device, owing to inadequate knowledge of progress of the drifting operation. The drifting apparatus described here automatically controls the temperature of the detector that is being drifted to maintain the leakage current at a preselected value. While drifting proceeds, a continuous measurement is made of the distance of the lithium-drifted region from the opposite face of the wafer. When the drifted region reaches 30 mil or less from the back of the wafer a meter indicates the thickness of the undrifted region and, when this thickness falls below a preselected value, the temperature of the detector is automatically reduced to room temperature. The need for constant supervision of the drifting operation is thereby eliminated, and reliance on theoretical drift-rate calculations to predict the drift-through time is avoided. The technique has been applied to the manufacture of lithium-drifted silicon detectors with excellent results.

The application of the technique to lithium-drifted germanium γ detectors is also discussed briefly.

Introduction

Lithium drifting in p-type silicon to produce thick depletion layers is now a well-established technique, and recent work by Williams¹ and Tavendale² and other groups, including ours, indicates the importance of this technique when applied to germanium to produce low-temperature γ -ray detectors. In early types of silicon lithium-drifted detectors the drifted region was allowed to proceed only part way through the slice of silicon, thereby avoiding problems of charge injection from the face opposite the lithium side. However, the window resulting at one side from the thick lithium diffusion (≈ 5 to 10 mils) and at the other side from the undrifted silicon was unsatisfactory for many purposes. It has now become standard practice to drift completely through the silicon slice, then to etch the side opposite to the lithium diffusion and to form what is loosely termed a "gold surface barrier" at this face. (Although the face opposite the lithium diffusion is used as the entry port for particles, we refer to it as the "back" of the detector, since it seems natural for a device engineer to regard the junction as the front.) This produces a very thin window at the back of the detector.

A number of parameters control the drift process, and the major differences between the various groups working in the field lies in their choice of optimum parameters. We refer here only to silicon, for which the art is well established, and deal with germanium very briefly at the end of this paper. Parameters that affect the drifting process include the following.

(a) Resistivity of original "p" type silicon. The higher the resistivity, the lower the temperature at which silicon becomes intrinsic and, therefore, the lower the possible drift temperature. However, quite adequate drift rates are possible for resistivities as high as 2000 Ω cm (intrinsic temperature about 150° C). Most manufacturers and laboratories use low-resistivity silicon (≈ 100 Ω cm) because of its availability and low cost. The cost is a small factor; material costs are negligible in these detectors.

(b) Temperature. The drift rate is a very sensitive function of temperature, and several groups, led originally by Miller,³ drift at very high temperatures ($\approx 150^\circ$ C), which are controlled by allowing the power developed in the device by its leakage current to be dissipated by immersion in a liquid fluorocarbon that boils at the surface of the device. This method accomplishes very fast drifting of thick detectors. Earlier work was usually carried out by drifting at lower temperatures ($\approx 120^\circ$ C) with the device clamped to a hot plate. This required longer drift times, but the degree of compensation in the drifted region was probably more exact than in detectors drifted at high temperatures, since lithium enters the lattice in such a way as to compensate the thermally generated carriers (which are a bigger component at higher temperatures) as well as the fixed acceptors. In several cases, groups using the high-temperature process carry out a final lower-temperature drift to redistribute the lithium.

(c) Drift time. In principle, drifting is terminated at the time when the drifted region reaches the back of the device. Since no method of measuring the exact time at which this occurs has been available, it has been common practice to calculate the time for drift-through. Unfortunately this calculation can be substantially in error, owing mainly to uncertainty about the device temperature. In general, several devices are drifted on a single hotplate whose temperature is not the same at all points, and also the thermal resistance between the device and the hotplate is an unknown and variable quantity.

The work described in this paper has been based upon the assumption that a completely automatic drifting process capable of drifting lithium in silicon at the minimum possible rate, and of monitoring the drift process so as to terminate it at the correct time, would be a useful contribution to the art of making lithium-drifted detectors. Emphasis on low drift rates and correct termination of the drift process has arisen from the observation that detectors produced by earlier techniques exhibit varying degrees of polarization when used at low temperatures. One possibility seems to be that excess lithium, which may become electrically inactive in the lattice, contributes traps that cause polarization. As this would certainly be a function of the total quantity of lithium drifted into the silicon, we have chosen to work with high-resistivity material ($\approx 1500 \Omega \text{ cm}$), although the automatic drift technique is capable of working in other resistivity ranges.

Evidence available is still insufficient to confirm that polarization effects are absent in low-temperature applications of detectors produced by this technique, although a few detectors have been tested without observing any evidence of polarization. However, the value of the automatic technique in other respects has been amply demonstrated. Eight units of the type described here have been in use for lithium drifting in silicon for almost 2 months, and the ease with which drifting can be accomplished, with the expenditure of very little human effort, is quite impressive. The slower drifting used here (as compared with that used by other groups) is no disadvantage, as the machine requires no intervention on the part of the operator and, when drifting is completed, the process is automatically terminated and the device is maintained under reverse bias at room temperature until the operator removes it from the drift oven. In fact, before starting a drifting operation, the operator can select a precise distance from the back of the wafer at which drifting will be stopped. For many detector applications, no further processing is required on the back surface, and problems due to current injection at the back are completely avoided. In other applications, a brief process is required to produce a thin uniform window.

Technique of Measurement and Control

Automatic control of the drift operation is based on measurements of two parameters taken continuously during drifting. For the greater part of the drift cycle control is exercised over the temperature of the wafer to maintain the detector leakage current constant. To accomplish this a high-power silicon transistor is attached to a copper block on which the wafer sits, and the power applied to the block by the transistor (30 watts maximum) is controlled according to the signal generated by a difference amplifier which compares the leakage current with a switched (demand) current. During all parts of the drift cycle, drift voltage of about 500 V is applied to the lithium face of the wafer.

To determine the distance of the undepleted

region from the back surface of the wafer (note that the lithium-drifted region is extended by a depleted region into the undrifted "p" material), the resistance between two conducting layers on the back surface of the wafer is measured. As the depleted region approaches the back of the wafer, the resistance rises, and its value, at any time, is a direct measure of the distance of the depleted region from the back of the wafer. Choice of the contact geometry on the back is arbitrary, but we have standardized on a gold evaporation onto a lapped back with a masking ring sitting on the wafer surface to give the pattern shown in Fig. 1. Calculation of the impedance between the two gold regions is simple if the thickness of the undepleted region is much less than 1 mm, and, as small window thicknesses are of most interest, the result of the calculation is accurate enough for our purpose:

$$R \approx 0.1 \rho/W, \quad (1)$$

where ρ = resistivity of p-type silicon,

W = thickness of undepleted region

(e. g., for $W = 10^{-3}$ cm, $\rho = 1000 \Omega \text{ cm}$,

$$R \approx 100 \text{ k } \Omega).$$

The drifting process is terminated when the resistance reaches a preset value selected by the operator prior to the start of the drifting.

The measured resistance includes a component due to the contact resistance of the evaporated gold layer with the silicon. To reduce this to a small value care must be taken to clean the surface thoroughly prior to evaporation. It is possible, with good techniques, to reduce this resistance to less than 2 k Ω at room temperature. This is small compared with the resistance values of greatest interest, and it becomes smaller at drift temperatures. Another difficulty in interpreting resistance readings arises because of variation of resistivity of the silicon with temperature. Typically, the resistivity increases by about a factor of two between room temperature and 120° C, owing to a reduction in mobility caused by lattice scattering. Above 120° C the resistivity decreases rapidly as the number of thermally excited carriers begins to increase. As our drifting is carried out in the temperature range 120 to 130° C, we use a factor-of-2 increase in resistivity in interpreting resistance readings. One result of this resistivity variation is evident at the end of the drift period. When the resistance measurement indicates that the window W has the desired thickness the temperature of the wafer is automatically reduced. However, the resistivity decreases as the temperature falls, thereby tending to force drifting to continue. The result is a slow reduction of temperature under control of the resistance-measuring circuit so that the final window corresponds to the preset resistance value as measured at room temperature.

Description of Apparatus

A cutaway view of the drifting oven is shown in Fig. 2. The hotplate, consisting of a hollow block of copper, is enclosed in an asbestos heat shield, and a controlled heat leak through three brass legs causes the block to cool at a fairly rapid rate ($5^{\circ}\text{C}/\text{minute}$ from 125°C) when the heat source is turned off. Heat is supplied by a power transistor mounted within the block. The transistor is operated at 30 watts maximum power and is capable of heating the block from room temperature to 125°C in about 12 minutes. The three legs mount on a $1/4$ -in. -thick copper plate which also serves as a heat sink for seven similar units. Water or forced-air cooling of this plate is desirable if all eight units are operated simultaneously.

The wafer to be drifted is mounted on the flat top surface of the copper block and pushed beneath the steel spring arm, which applies drift voltage to the device. At the same time, the insulated spring wire pushing through the hole at the center of the top surface of the block makes contact with the central evaporated gold region on the wafer. Measurement of the resistance between this wire and the copper block is used for window control. A microswitch (not shown in Fig. 2) breaks the drift supply voltage when the asbestos cover of the oven is removed. A thermocouple (not shown in Fig. 2) is mounted on one side of the copper block.

Figure 3 shows the circuit of the control unit. In our unit, eight circuits mount in a single bin and meters are switched between the various control units. A temperature indicator, also switched, allows determination of the approximate temperature in each drift oven. Only a brief description of the circuit of Fig. 3 is given, as its operation is fairly conventional. The device leakage current, shared between the two back contact areas, passes through transistors Q-4 and Q-5 into the base of Q-10. At the same time, the switched demand current flows out of this base. This current may be set to 0, 1, 2, 4, or 8 mA. If a drift operation is just starting, the device leakage current is low, and, if the demand switch is set to 1 mA, transistor Q-10 is nonconducting. Q-11 will therefore conduct, driving Q-12 and the heater transistor Q-13 into conduction. Power in Q-13 is limited to a safe value by collector saturation of Q-12 and the effect of the $10\text{-}\Omega$ emitter resistance in Q-13. The temperature of the drifting oven rises until the detector leakage current increases to 1 mA (the demand setting), at which time Q-10 comes into conduction and the temperature controller assumes control to maintain the current at 1 mA.

The resistance between the two evaporated gold regions on the back of the detector is measured by a pulse method. An ac method is required to separate the effect of device leakage current from that due to the resistance. A 1-kc/sec emitter-coupled multivibrator applies positive 1-V $100\text{-}\mu\text{sec}$ pulses to the base of Q-4. The resulting pulse current in Q-4 is due mainly to current flowing through the undepleted region of the detector between the emitters of Q-4 and Q-5. Q-6 and

Q-7 amplify the pulse current in Q-4 and produce a pulse voltage signal at the collector of Q-7 given by

$$V_{\text{pulse}} \approx (15/R) \times 10^3. \quad (2)$$

The negative pulse output signal at the collector of Q-7 is ac-coupled to the base of Q-8, and dc restored at this point with respect to a preset value determined by the window control. Q-8 rectifies the pulse wave form, with the result that the dc voltage developed at the base of Q-9 is equal to the setting of the window control minus the rectified pulse voltage. When the drift process starts, R is small and the base of Q-9 is at a negative potential, so the window meter connected to its emitter indicates a thick window. As drifting proceeds R increases, the meter indication becomes smaller, and, at a value of R determined by the setting on the window control, the meter reading becomes zero. When this happens, the diode connecting the emitter circuit of Q-9 to the common emitters of Q-10 and Q-11 conducts. As R becomes larger (i. e., the window becomes smaller) Q-9 conducts, reducing the current in Q-11 and, thereby, also the drive to power transistor Q-13. The temperature then falls under the control of the window-measuring circuit.

Wafer Preparation and Detector Finishing Steps

Our present method of making detectors is described very briefly, although this is changed frequently as ways to improve it become apparent. The steps in the process are as follows.

(a) Wafers are cut from floating-zone silicon to a thickness about 8 mils larger than the desired sensitive thickness.

(b) Wafers are lapped, care being taken to maintain front and back surfaces as parallel as possible. Experience indicates that 0.25-mil parallelism is not too difficult to achieve.

(c) Wafers are thoroughly washed with detergent, trichloroethylene, and methyl alcohol.

(d) Lithium is evaporated and diffused through a suitable mask onto one side of the wafer. The size and shape of the evaporated region depends upon the application of the detector. Excellent control of the depth of lithium diffusion results from preheating the wafer to 400°C in the vacuum evaporator, evaporating for 1 minute, then stopping the evaporation and cooling the wafer rapidly by passing cold water through a cooling coil mounted on the heater strip (this process was worked out by Walter Stockton and Harry Smith). This process results in about 3-mil diffusion depth.

(e) The gold contact structure is evaporated on the back of the wafer.

(f) A mesa is now etched on the lithium face of the wafer. The depth of etch is about 5 mils.

(g) Wafers are now drifted with the window control set to terminate drifting when the window at the back face is about 2 mils thick. During drift the demand current is generally set to a value that results in a wafer temperature in the range 110 to 130°C . Currents are usually 1 or 2 mA if the surfaces are properly cleaned following the mesa etch.

(h) When drifting is completed, a decision is

made on the basis of requirements as to the type of window necessary in the device. If a thin window is not important a gold evaporation over the existing contact structure is all that is required. If a thin window is required, the original gold contact structure is removed by aqua regia followed by HF. By masking the front of the detector and a 2-mm ring around the edge of the back with Picein, one retains a ring of the original gold at the back of the device. The remainder of the back is then etched to a depth of 4 mils, resulting in a shallow well-shaped structure on the back of the device. Masking is removed with trichloroethylene and the wafer is cleaned thoroughly with methyl alcohol. The wafer is then left standing in room air for 24 hours and a surface barrier is formed on the back by a gold evaporation.

(i) The junction edge (i. e., around the lithium mesa) is protected by setting the surface states (wash with 1:1 HF:H₂O for 15 sec followed by 1-min wash in methyl alcohol), then painting with a silicone varnish (Dow-Corning 991).

Application of Technique to Germanium Detectors

The automatic drifting technique described here has been applied to germanium lithium-drifted detectors, but no attempt has yet been made to control the window thickness as in the silicon counters. In the germanium detectors drift conditions are very different from those used with silicon detectors, but the same basic controller is used. Drift temperatures are in the range 20 to 70° C, drift currents in the 10- to 100- mA range, and voltages from 100 to 1000 V. The large power dissipation in the device requires very good thermal contact between the device and the hotplate, and the thermal resistance of the heat leakage path from the hotplate must be decreased (as compared with the silicon drift oven) to prevent device runaway. To accomplish these objectives a liquid metal alloy is applied on the back of the germanium detector, a brass tube replaces the legs on the silicon oven, and the cold plate is refrigerated. The automatic drift process is even more valuable for germanium than silicon, as manual operation of the drift process is extremely tedious because of the continuous changes that occur in drift conditions during a period of several hours at the start of drifting.

Two major problems occur frequently in lithium-drifted germanium detectors. The tendency of lithium to precipitate at vacancies in germanium results in disappearance of lithium from its electrically active state during the drift process. Its behavior is improved by diffusion of copper at the same time as lithium in the initial diffusion process, as copper fills the vacancies and reduces the lithium precipitation rate by a large factor.⁴ A further difficulty arises owing to the extreme sensitivity of germanium detectors to surface effects, particularly when stored even for brief periods at room temperature in normal environments. We have found no solution to this problem except to protect the junction edge with a silicone rubber (RTV102), and to arrange to avoid exposure of the device to deleterious conditions.

Acknowledgments

The contributions of Harry Smith, Blair Jarret, Morris Roach, Stuart Wright, and Richard Davis to this work are gratefully acknowledged. The work described here was carried out as part of the program of the Nuclear Chemistry Department of the Lawrence Radiation Laboratory, under contract with the U. S. Atomic Energy Commission.

References

1. P. P. Webb and R. L. Williams, Gamma-Ray Spectroscopy using a Germanium Lithium-Drifted Diode, Nucl. Instr. Methods 22, No. 2, 361 (1963).
2. A. J. Tavendale, Characteristics of Lithium-Ion Drift Germanium Gamma Spectrometers, -paper presented at The International Symposium on Nuclear Electronics, Paris, Nov. 1963.
3. G. L. Miller, B. D. Pate, and S. Wagner, Production of Thick Semiconductor Radiation Detectors, I. R. E. Trans. Nucl. Sci. NS-10 (1), 220 (1963).
4. J. R. Carter and R. A. Swalin, On the Kinetics and Mechanism of the Precipitation of Lithium from Germanium, J. Appl. Phys. 31 (7), 1191 (1960).

FIGURE CAPTIONS

Fig. 1 - Evaporated gold contact geometry.

Fig. 2 - Drifting oven: cutaway view. (Asbestos
oven cover not shown.)

Fig. 3 - Control circuit schematic.

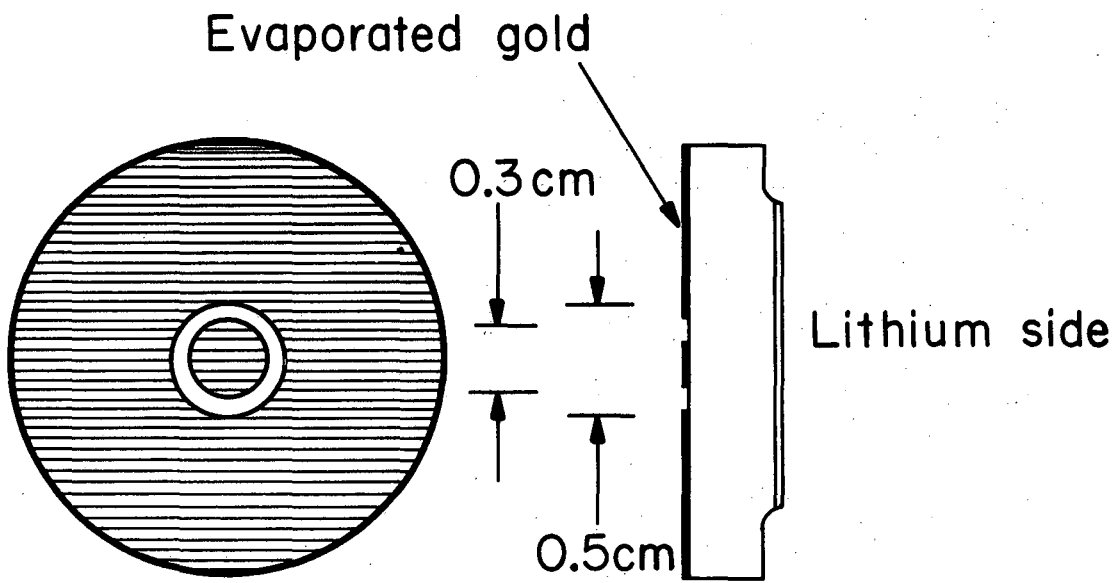

MU - 33306

Fig. 1

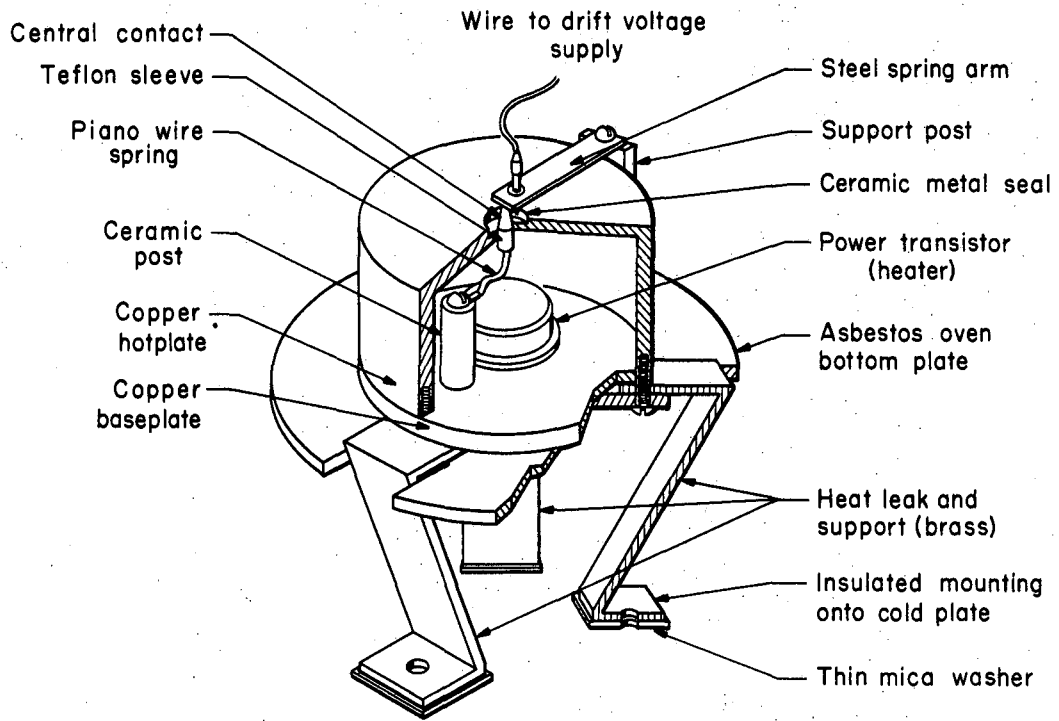

MU-33307

Fig. 2

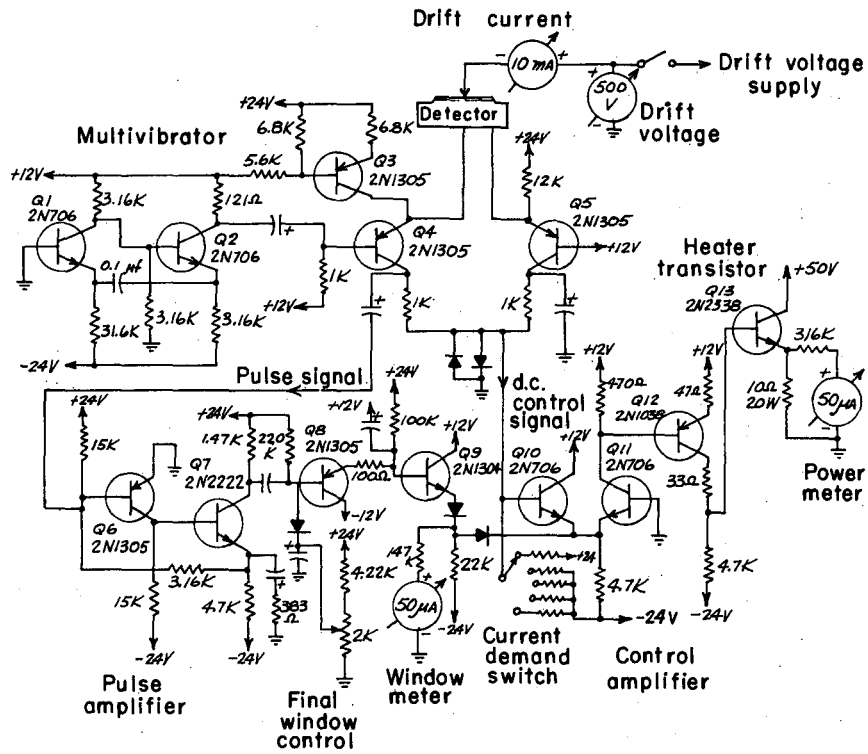

MU-33308

Fig. 3

This report was prepared as an account of Government sponsored work. Neither the United States, nor the Commission, nor any person acting on behalf of the Commission:

- A. Makes any warranty or representation, expressed or implied, with respect to the accuracy, completeness, or usefulness of the information contained in this report, or that the use of any information, apparatus, method, or process disclosed in this report may not infringe privately owned rights; or
- B. Assumes any liabilities with respect to the use of, or for damages resulting from the use of any information, apparatus, method, or process disclosed in this report.

As used in the above, "person acting on behalf of the Commission" includes any employee or contractor of the Commission, or employee of such contractor, to the extent that such employee or contractor of the Commission, or employee of such contractor prepares, disseminates, or provides access to, any information pursuant to his employment or contract with the Commission, or his employment with such contractor.

