

Lawrence Berkeley National Laboratory

Recent Work

Title

ALS Insertion Device Block Measurement and Inspection

Permalink

<https://escholarship.org/uc/item/9z32t0zd>

Authors

Marks, S.
Carrieri, J.
Cook, C.
[et al.](#)

Publication Date

1991-05-01



Lawrence Berkeley Laboratory

UNIVERSITY OF CALIFORNIA

Accelerator & Fusion Research Division

Presented at the IEEE Particle Accelerator Conference,
San Francisco, CA, May 6-9, 1991, and to be
published in the Proceedings

ALS Insertion Device Block Measurement and Inspection

S. Marks, J. Carrieri, C. Cook, W.V. Hassenzahl,
E. Hoyer, and D. Plate

May 1991

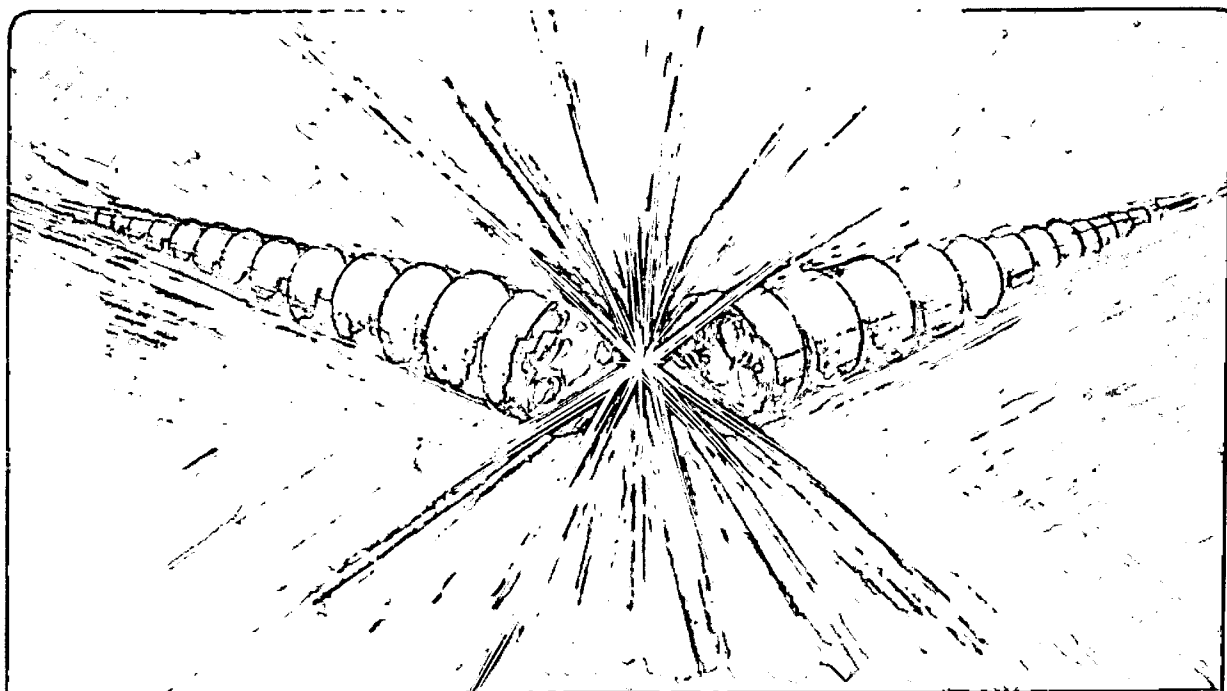

LOAN COPY |
Circulates |
for 4 weeks | Bldg. 50 Library. |
Copy 2

LBL-29955

DISCLAIMER

This document was prepared as an account of work sponsored by the United States Government. While this document is believed to contain correct information, neither the United States Government nor any agency thereof, nor the Regents of the University of California, nor any of their employees, makes any warranty, express or implied, or assumes any legal responsibility for the accuracy, completeness, or usefulness of any information, apparatus, product, or process disclosed, or represents that its use would not infringe privately owned rights. Reference herein to any specific commercial product, process, or service by its trade name, trademark, manufacturer, or otherwise, does not necessarily constitute or imply its endorsement, recommendation, or favoring by the United States Government or any agency thereof, or the Regents of the University of California. The views and opinions of authors expressed herein do not necessarily state or reflect those of the United States Government or any agency thereof or the Regents of the University of California.

**ALS INSERTION DEVICE BLOCK MEASUREMENT AND
INSPECTION***

S. Marks, J. Carrieri, C. Cook, W.V. Hassenzahl, E. Hoyer, and D. Plate

Accelerator and Fusion Research Division
Lawrence Berkeley Laboratory
University of California
Berkeley, CA 94720

May 1991

Paper presented to the IEEE Particle Accelerator Conference, San Francisco, CA, May 6-9, 1991

ALS INSERTION DEVICE BLOCK MEASUREMENT AND INSPECTION

S. Marks, J. Carrieri, C. Cork, W.V. Hassenzahl, E. Hoyer, and D. Plate

Accelerator and Fusion Research Division, Lawrence Berkeley Laboratory
University of California, Berkeley, California 94720

Abstract

The performance specifications for ALS insertion devices require detailed knowledge and strict control of the Nd-Fe-B permanent magnet blocks incorporated in these devices. This paper describes the measurement and inspection apparatus and the procedures designed to qualify and characterize these blocks. A detailed description of a new, automated Helmholtz coil facility for measurement of the three components of magnetic moment is included. Physical block inspection and magnetic moment measurement procedures are described. Together they provide a basis for qualifying blocks and for specifying placement of blocks within an insertion devices' magnetic structures.

I. INTRODUCTION

The Advanced Light Source (ALS) at the Lawrence Berkeley Laboratory will use insertion devices, wigglers and undulators, to produce intense photon beams. These insertion devices are designed as hybrid structures that include Nd-Fe-B blocks as the source of magnetic field that energizes vanadium permendur poles. The basic structure is illustrated in Figure 1, which shows a pole assembly including six magnetic blocks. Each insertion device typically contains between 1,000 and 3,000 blocks. The block specifications are summarized below :

- Nominal Principal Magnetic Moment per Unit Volume $M_z = 10.6$ kOe or greater
- Minimum allowed $M_z = 10.4$ kOe
- Allowed variation in $M_z = \pm 2.5\%$
- Alignment of magnetic axis = $\pm 3^\circ$.

The midplane magnetic field of an insertion device, which determines the spectral performance, is dominated by the shape and placement of the poles and the total flux entering the poles due to the adjacent Nd-Fe-B blocks. Therefore, the primary requirements for the blocks are on the principal magnetic moment, M_z . The peak midplane magnetic field determines the nominal value of this moment. The allowable block to block variation is determined by the acceptable variation in the midplane field. For previous insertion devices designed at LBL, this was the only requirement. Experience with previous designs and increased performance specifications led to additional block specifications for ALS insertion devices. New considerations concern the off axis components of the magnetic moment, which cause beam steering, and the distribution of flux perpendicular to the beam direction, which is associated with quadrupole and higher order multipoles. These affects are most significant near the midplane where they have the greatest effect on the beam.

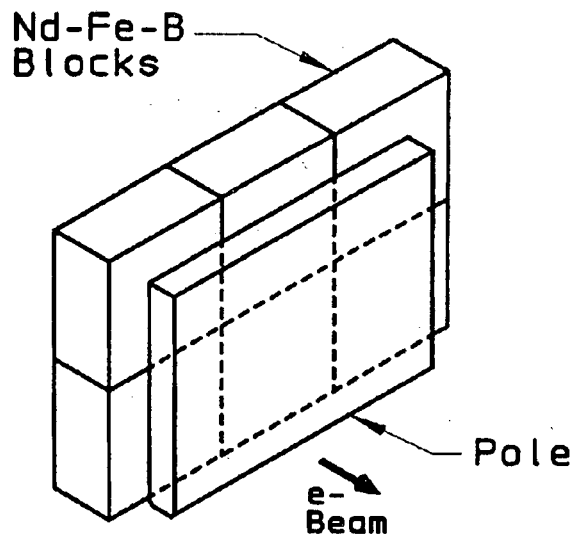

Fig. 1. Insertion Device Pole Structure for ALS U5.0.

II. PHYSICAL INSPECTION

The first step in block qualification is a physical inspection. This includes a visual inspection, dimensional checks, and a qualitative magnetic field check using magnaview film (Edmund Scientific stock number 33447). The visual inspection screens the blocks for flaws in the plating, cracks and surface voids larger than 2 mm. The block width and thickness are checked by passing the blocks through two "go"/"no-go" gauges. Blocks that fall within the tolerance fit through the "go" part of the gauge, indicating that it is not too large, but do not fit through the "no-go" part of the gauge, indicating that it is not too small.

The magnaview film consists of an emulsion of fine iron grains contained between two translucent plastic sheets. When exposed to a magnetic field the metal grains align themselves with the local field direction. When held under a light source, the grains aligned in the plane of the paper reflect and this region appears light. Other regions appear dark. By putting a sheet of the magnaview film in contact with a block and viewing under a light, one can get a picture of the magnetic quality of the block.

III. HELMHOLTZ COIL SYSTEM

After the blocks have been examined by the procedure described above, the Helmholtz coil system is used to measure magnetic moment. The following objectives were established for a new Helmholtz coil system.

- 1) The system must measure three components of magnetic moment to an accuracy of +/- 0.1% of the main component, M_z .
- 2) The system must be fast; capable of processing at least 20 blocks per hour.
- 3) The system must be easy to use and must minimize the possibility of human error.
- 4) The system must store data in a standard, secure and accessible format.

The first three requirements, coupled with the need to measure upwards of 10,000 blocks, motivated the design of an automated system. This was based on the recognition that the manual procedure used previously was slow, extremely tedious and prone to operator error, and would be incompatible with the construction schedule and the large number of blocks to be measured. The fourth requirement motivated the incorporation of a standard commercial data base system into the data acquisition software.

The Helmholtz coil functions in the following way. When a block at or near the center of a Helmholtz coil is rotated continuously, a periodic voltage is induced according to Equation (1) below.

$$V(t) = \frac{N\omega}{RG} [m_y \cos(\omega t) + \{m_z \cos(\chi) + m_x \sin(\chi)\} \sin(\omega t)], \quad (1)$$

where N is the number of turns in each of the two coils, R is the radius of the coils (m), $G = 1.3975$ is the geometry factor for a Helmholtz coil pair [1], and ω is the rotation rate (radians per second) for the block. The angle χ corresponds to the angular orientation of the block with respect to the spin axis. The three components of magnetic moment are determined by first rotating the block about an axis parallel to m_x , $\chi = 0^\circ$, and then flipping the block so that it rotates about m_z , $\chi = 90^\circ$. A Fourier decomposition of the sampled voltage for the first orientation determines m_z and m_y . Components m_x and m_y are determined from the second orientation (note the redundant measurement of m_y).

The Helmholtz coil voltage is sampled 256 times per revolution, for 10 revolutions, for both configurations, $c = 0^\circ$ and $c = 90^\circ$. The voltage is corrected for the instantaneous velocity and the values from each revolution are Fourier analyzed separately. The average of the 10 resulting amplitudes is used for the value of the moment and the variation as a measure of the error.

A. Hardware

Figure 2 is a photograph of the Helmholtz coils and the associated mechanical hardware. The system consists of two 60 cm diameter coils and a rotating block holder driven by a servo motor. A linear actuator is coupled to the head assembly and produces the 90° block flip. The magnetic blocks are secured in the head with a keyed fixture. An incremental rotary disk encoder is attached directly to the spin axis.

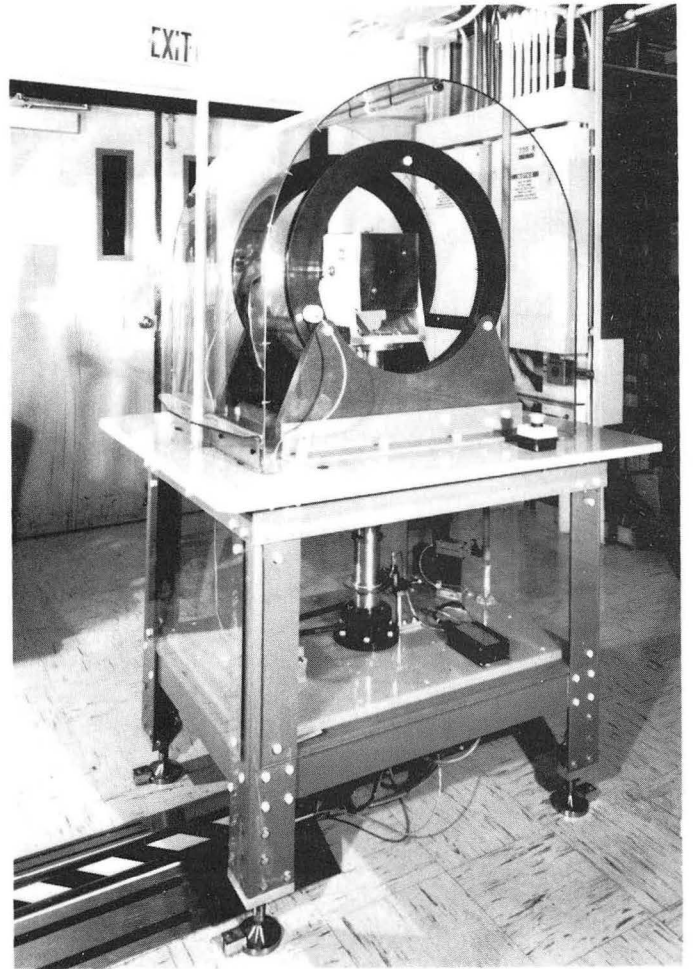

Figure 2. Helmholtz Coil and Mechanical Hardware

The magnetic moment measurement system also includes an operator interface stand and an electronics rack. The operator stand includes a Sun 3/80 workstation and an operator "keystation." The workstation is the operator interface during measurements; it performs all the data processing, database storage and access to measurement results. The "keystation" is a safety feature that prevents access to the block holder while it is rotating. When the key that is used to lock the block into the holder is inserted into the "keystation", a Lexan shield is lowered, the head is allowed to rotate, and the test begins.

The electronics rack contains various instruments and a real-time subsystem for fast data collection and instrument control. The equipment includes a VME crate, a Hewlett Packard 3458A digital voltmeter (DVM), a Compumotor KHX-250 servo driver/controller for the block rotation motor, and a Compumotor AX driver/controller for a linear actuator that executes the block flip. The VME crate includes a Motorola MVME-147 real time central processing unit (CPU), a Burr Brown MPV991 timer/counter module, and a Motorola MVME-300 GPIB controller.

The MVME-147 provides real-time data collection and instrument control. The DVM samples the coil voltage, which is stored in internal memory. Sampling occurs when triggers are

received from the timer/counter module, which processes 1024 pulses per revolution from the Teledyne Gurley model 8708 ring encoder. Time between pulses is measured to provide angular velocity information.

Figure 3 is a logical block diagram of the hardware components and their interconnections. The DVM is controlled and its data is retrieved via GPIB. The motor driver/controllers are connected to the MVME-147 via RS-232 ports. Communication between the MVME-147 and the Sun 3/80 workstation occurs over an Ethernet interface.

B. Software

The software is divided into two major subsystems that correspond to the real-time hardware and the operator workstation. Coordination between the subsystems is provided by using the Sun remote procedure call (RPC) mechanism. Figure 4 is a block diagram of the software modules.

The *Mv300* module controls the MVME-300 GPIB control board. The *Dvm* interface module is for communication with the DVM via the IEEE-488 interface bus and the *Mv300* device handlers. The device handler for the MPV991 timer/counter module, *Mpv991*, provides services for access and control of the parallel counter channels and interrupt controller. *Encoder* is an interface module for setup, initiation, and sampling of the MPV991 timer/counter with the specific hardware interconnections for our system where it is interfaced with the spin axis incremental encoder. *Flip* is an interface module for communication with the flip axis motor driver. The module is used to initialize and calibrate the flip axis positioner as well as toggle between the two measurement configurations. *Scan_svc* is the top level server task on the real-time subsystem that provides remote procedure call service to client tasks. This task is spawned during system initialization and it listens to the network for service requests. *Scan_clnt* is the client interface module. It resides on the operator workstation as a subroutine library that coordinates network connections, RPC access, and disconnection to the server module. *ScanMaster* is the routine that runs on the operator workstation and provides basic coordination of the measurement, user prompts and information, retrieves and processes data, and stores measurement results. Results are stored in an Informix database; access to the database is provided by structured query language subroutine calls embedded in *ScanMaster*.

IV. CONCLUSIONS AND OBSERVATIONS

The Helmholtz coil system described above has been operational since January 1991. A total of 4866 Nd-Fe-B blocks have been successfully measured. An average measurement rate of 20 blocks per hour was sustained while it was in operation, and peak measurement rates were as high as 40 blocks per hour. Repeatability of measurements was verified by remeasurement of a reference block before and after each day's sequence of measurements. This block was measured over 100 separate times during

this period. The standard deviation of these measurements was +/- 0.04%, some of which is due to temperature variation that can be corrected for.

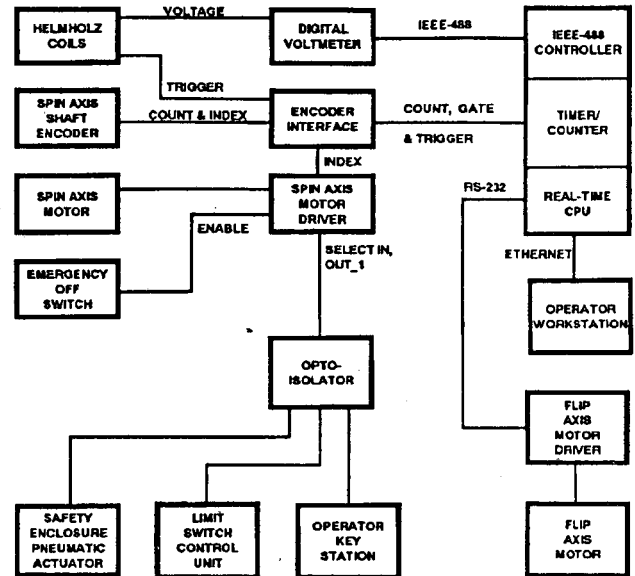

Figure 3. Block Diagram of Helmholtz Coil Hardware Components

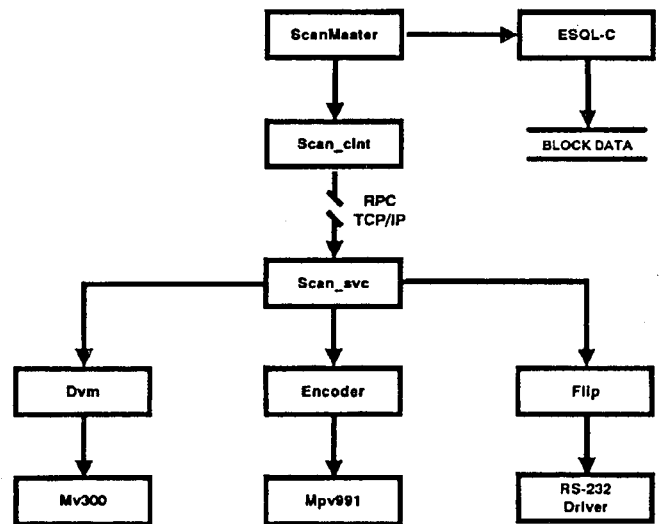

Figure 4. Block Diagram of Software for Helmholtz Coil Automated Block Measurements

V. ACKNOWLEDGMENT

This work was supported by the Director, Office of Energy Research, Office of Basic Energy Sciences, Materials Sciences Division of the U.S. Department of Energy, under Contract No. DE-AC03-76SF00098

V. REFERENCES

- [1] D. H. Nelson, F. H. Pao, R. L. Schermer, and D. A. Van Dyke, "Magnet Moment Measurements of Permanent Magnet Blocks by the Lawrence Berkeley Laboratory Magnet Measurement Engineering Group", MT400, December, 1989.

LAWRENCE BERKELEY LABORATORY
UNIVERSITY OF CALIFORNIA
INFORMATION RESOURCES DEPARTMENT
BERKELEY, CALIFORNIA 94720