

# Assessment of Critical Barriers to Alternative and Renewable Fuel and Vehicle Deployment – Workshop Series

June 2016

A Workshop Report Series from the National Center for Sustainable Transportation

Andrew Burke (co-PI), University of California, Davis  
Amy Myers Jaffe (co-PI), University of California, Davis  
Lew Fulton, University of California, Davis  
Rosa Dominguez-Faus, University of California, Davis  
Marshall Miller, University of California, Davis  
Hengbing Zhao, University of California, Davis  
Guozhen Li, University of California, Davis  
Raphael Isaac, University of California, Davis  
Paul Gruber, University of California, Davis



National Center  
for Sustainable  
Transportation

**UCDAVIS**

**SUSTAINABLE TRANSPORTATION ENERGY PATHWAYS**

*of the Institute of Transportation Studies*

## **About the National Center for Sustainable Transportation**

The National Center for Sustainable Transportation is a consortium of leading universities committed to advancing an environmentally sustainable transportation system through cutting-edge research, direct policy engagement, and education of our future leaders. Consortium members include: University of California, Davis; University of California, Riverside; University of Southern California; California State University, Long Beach; Georgia Institute of Technology; and University of Vermont. More information can be found at: [ncst.ucdavis.edu](http://ncst.ucdavis.edu).

## **U.S. Department of Transportation (USDOT) Disclaimer**

The contents of this report reflect the views of the authors, who are responsible for the facts and the accuracy of the information presented herein. This document is disseminated under the sponsorship of the United States Department of Transportation's University Transportation Centers program, in the interest of information exchange. The U.S. Government assumes no liability for the contents or use thereof.

## **UC Davis Disclaimer**

The primary purpose of this report is to summarize insights from the April 26, 2016 workshop. Therefore, the views and recommendations expressed by workshop participants, and detailed in this report, do not necessarily reflect the views of the UC Davis research team.

## **California Energy Commission Disclaimer**

This report was prepared as the result of work sponsored by the California Energy Commission. It does not necessarily represent the views of the Energy Commission, its employees or the State of California. The Energy Commission, the State of California, its employees, contractors and subcontractors make no warrant, express or implied, and assume no legal liability for the information in this report; nor does any party represent that the uses of this information will not infringe upon privately owned rights. This report has not been approved or disapproved by the California Energy Commission nor has the California Energy Commission passed upon the accuracy or adequacy of the information in this report.

## **Acknowledgments**

This study was funded by a grant from the National Center for Sustainable Transportation (NCST), supported by USDOT through the University Transportation Centers program. The authors would like to thank the NCST and USDOT for their support of university-based research in transportation, and especially for the funding provided in support of this project.



# Assessment of Critical Barriers to Alternative and Renewable Fuel and Vehicle Deployment – Workshop Series

## INTRODUCTION

The University of California, Davis and the California Energy Commission held a series of three Emerging Technologies Workshops in late 2015 and early 2016. The goal of these workshops was to identify environmentally and economically promising alternative fuel and vehicle emerging technologies, and to identify and evaluate the critical business and policy barriers blocking their widespread adoption in the State and develop solutions for those barriers. Additionally, the workshops were to analyze the broad range of commercial barriers and identify strategies to increase the adoption and rapid scale-up of emerging technologies, fuels and fueling infrastructure that will help the state achieve its goals for air quality and greenhouse gas emissions.

Each of these workshops convened groups of over 100 stakeholders engaged in the commercialization of emerging technologies for the light-, medium- and heavy-duty transportation sectors. Participants included manufacturers of incumbent and emerging alternative vehicle technologies, manufacturers of traditional and alternative fueling infrastructure, traditional and alternative fuel (including electricity) producers and suppliers, financial institutions and investors, and public agencies concerned with energy, the environment, transportation, and the California economy.

Following the workshops, Emerging Technology Workshop Reports were prepared, detailing the findings and discussions from each workshop. Abstracts for each workshop report is included below:

### **Assessment of Critical Barriers and Opportunities to Accelerate Biofuels and Biomethane as Transportation Fuels in California**

*September 17, 2015*

This report summarizes the findings and recommendations of the workshop and related backup materials concerned with the status of biofuels technologies, current and projected markets for biofuels, and government policies and regulations.

At the present time, the primary biofuels being marketed in the U.S. are corn-derived ethanol blended with gasoline (15 bg/y) and soy-bean derived FAME biodiesel blended with standard diesel fuel (2 bg/y). This represents about 10% of gasoline sales and 5% of diesel sales in the U.S. The other biofuel currently being produced in significant quantities (2.3 bgge/y) is renewable natural gas (biomethane), which is primarily used, in the same location that it is produced, to generate electricity. The size of the markets for these biofuels is determined



primarily by two major government policies, the Federal RFS (renewable fuel standard) and the California LCFS (low carbon fuel standard), both of which are expected to become more stringent in future years.

Currently most biofuels are produced from corn (ethanol), soy bean and waste vegetable oils (biodiesel), and landfills and organic waste (biomethane). In 2014, less than one-half of the biodiesel was produced from waste vegetable oils. The feedstocks for liquid fuels are either of limited quantity or do not have an ultra-low carbon intensity. Their carbon intensity is greater than 30 (CI). Most future quantities of biofuels will need to be produced from cellulosic feedstocks to meet future RFS and LCFS regulations. The technologies to produce cellulosic ethanol, drop-in gasoline, renewable diesel, and renewable natural gas from cellulosic feedstocks are now under development with pre-commercialization levels of production, but they have not achieved a level of commercial readiness for large scale production. There is considerable uncertainty as to whether the many millions of metric tons required annually of the cellulosic feedstocks to fulfill U.S. Policy targets can become available. Other barriers to large scale production of biofuels include uncertainties in government policies and the need for long-term commitments, limited government funding for R&D and pilot production, and the need for large, risky capital investments for the scale-up of the technologies needed to produce billions of gge/yr of each of the biofuels. All of these uncertainties, or barriers, were discussed at the workshop and possible approaches, or solutions, to overcome them were identified and discussed.

## **Assessment of Critical Barriers and Opportunities to Commercialize Medium- and Heavy-Duty Truck Technologies in California**

*December 3, 2015*

This workshop attracted over 100 stakeholders from technology developers, fleet operators, government agencies, private investors, universities, and non-profit organizations. This report summarizes the findings and recommendations of the workshop and related information concerning the status of medium duty (MD) and heavy duty (HD) on-road and off-road vehicle technologies, current and projected markets for MD/HD vehicles, and government policies and regulations that will influence the growth of MD/HD vehicle markets in the next 10-15 years.

The major drivers for the development of advanced MD/HD vehicles are the need to reduce their greenhouse gas emissions and air quality related pollutants. The need to reduce the reliance of freight transportation fossil fuels is also a driver. The emissions from engines used in MD/HD vehicles, primarily diesel engines, have been regulated for many years, with the most recent standards set for 2010. Due to the high prices of fuel encountered throughout much of the last decade, there has been a desire among MD/HD vehicle operators to increase the fuel economy of their vehicles; however, it was not until 2011 that EPA/NHTSA set the first fuel efficiency and CO<sub>2</sub> emission standards for engines and MD/HD vehicles (Phase 1) as an element of climate change policy. The engine standards also included those on NO<sub>x</sub>. The Phase 1



standards for 2014-2017 are in the process of being made more stringent for 2018-2027 (Phase 2). These regulations are the primary drivers for the development of technology improvements (i.e. both vehicle and powertrain technologies) to reduce the fuel consumption and greenhouse gas emissions from MD/HD trucks and buses. EPA/NHTSA studies indicate that the 2027 standards that reduce fuel consumption and CO<sub>2</sub> emission by about 25% from the 2010 baseline can be met without the need for implementing advanced vehicle electrification technologies, such as hybrids, batteries, and fuel cells. Significant improvements in engine efficiencies, however, will be needed.

Advanced powertrain technologies for hybrid-electric, all-electric, and fuel cell powered MD/HD vehicles are being developed worldwide by large OEMs and small start-up companies. On-road demonstrations of all of these advanced technologies are underway for many types of trucks. These technologies and their costs relative to conventional engine/transmission technology are reviewed in this report. At the present time, the primary market for these advanced technologies is the transit bus market, where they are being sold in relatively large numbers worldwide. In particular, battery-powered buses are sold in China by the thousands per year by multiple bus suppliers and, in the United States, hybrid-electric buses represent about 30% of the new transit bus sales. Fuel cell-powered buses are also being demonstrated worldwide, though in small numbers. The costs of the advanced buses are much greater than the conventional buses in both the United States and China, and their sales are supported by government subsidies.

The continuing experiences with advanced buses indicate that the associated technologies are well-developed. As has been found with traction batteries used in vehicles of all types and sizes, it is expected that the cost of advanced vehicles and the components used in them will decrease markedly as the volume of production increases in the coming years. As discussed in the report, during this period of large cost reduction and technology improvements, the primary drivers of sales of advanced technology vehicles are government regulations and subsidies. Experience has shown numerous times that when subsidies are phased out, sales of the advanced technologies decrease very quickly unless these technologies are mandated by regulations. In this case, it can be expected that the Phase 1 and 2 EPA/NHTSA standards for all types of MD/HD trucks will be met without subsidies because of the regulations that are currently in place. Markets for MD/HD vehicles meeting regulations more stringent than Phase 2 will require significant reductions in the costs of advanced vehicles and technologies and/or more stringent regulations in the future.

### **Critical Barriers and Opportunities for PEV Commercialization in California: Infrastructure for Light-Duty Vehicles, Freight, and People Movement**

*April 26, 2016*

This report summarizes the status of the infrastructure for charging electric vehicles and its commercialization. It discusses insights from the workshop, in which over 130 stakeholders



from industry, government and academia participated. The workshop highlighted critical barriers to the commercialization and recommended actions to maximize and accelerate the commercialization. Part I of the report is concerned with the infrastructure for light-duty plug-in electric vehicles. Part II is concerned with the infrastructure for medium-duty and heavy-duty vehicles.

#### *Part I: Infrastructure for light-duty electric vehicles*

At the present time (April 2016), there are about 200,000 PEVs on the road in California and about 20,000 non-residential charging stations available to provide battery charging for them. The California ZEV Action Plan (2015) from the Governor's Office has set goals of 1 million PEVs by 2020 and 1.5 million PEVs by 2025. This will require about 200,000 non-residential charging stations by 2020 and about 300,000 stations by 2025. These charging stations must be placed so that PEV owners who do not live in single-family dwellings have convenient access to them. In addition, about 10,000 fast charging points must be built along the major highways in California so that PEVs can be used for inter-city travel. To date many of the charging stations have been built with funding from CEC and CARB, but in the future the major funding for the large expansion of charging stations needed will likely come from the investor-owned electric utilities who have shown a serious interest in providing infrastructure for electrification of transportation. It is critical that the CPUC formulate in the near future an acceptable approach for the involvement of the utilities in large infrastructure projects. Auto manufacturers could become involved in building infrastructure like Tesla, but that seems unlikely. Both the PEV and battery charger technologies that meet the car buying public's needs are available at decreasing costs as sales volumes increase. Hence a major factor in maintaining increasing sales of PEVs will likely be the timely building of the battery charging infrastructure needed by the new PEV owners. The cost of the infrastructure seems manageable being in the range of \$100-\$200 million per year between now and 2025. At the present time, the business case for installing and operating charging stations is difficult, but it will significantly improve as the numbers of electric cars on the road continues to increase.

#### *Part II: Infrastructure for medium-and heavy-duty electric vehicles*

At the present time there are less than 500 MD/HD electric vehicles on the road in California and the charging infrastructures for those vehicles have been designed and built specifically for them. Medium-duty electric delivery trucks/vans represent the largest number of MD/HD electric vehicles on the road and charging of their batteries can be done using available Level 2 chargers. Charging the batteries of transit buses and other HD vehicles requires special equipment due to the size (kWh) and high voltage of their battery packs. In the case of transit buses, the batteries can be slow charged (charging times of 6-8 hours) at the bus garages using special Level 3 chargers or fast charged (in less than 5 minutes) enroute using overhead charging units with which the buses are docked at selected bus stops. This latter approach requires high power (500-600 kW) and is used for Proterra buses by several transit agencies in California. Demonstrations of several heavy-duty class 8 electric trucks by TransPower utilize the motor inverter electronics on board the vehicle for charging their large (200 kWh) battery

packs. This requires the availability of a 240V or 480V 3-Phase, high power (at least 70 kW) electrical service for the battery charging.

The direct-connection technology for charging batteries in MD/HD electric vehicles appears to be well-developed and commercially available in the United States, Europe, and Japan. At the present time, high voltage, high power charging stations are expensive primarily because the products have not been standardized both because sales volumes are low and standards for both connectors/docking units and interface protocols have not yet been established.

Meetings are currently underway world-wide to establish the needed standards. Development of high power wireless charging technology is presently underway for HD electric vehicles. Deployment/demonstration of the wireless technology has only begun.

In most cases, the charging facilities for MD/HD electric vehicles will be provided by the vehicle operators in collaboration with the local electrical utilities. The business case for the charging stations should be reasonably attractive because they can be optimally sized for the fleet to be charged. For transit buses, funding for charging facilities is available as part of FTA grants for zero emissions vehicles. For demonstration projects, funding for small fleets and/or single vehicles is available in California with HVIP and CEC grants.

# Biofuels Commercialization, Technology, Emerging Markets, and Government Policies

May 2016

A Workshop Report from the National Center  
for Sustainable Transportation

Andrew Burke (co-PI), University of California, Davis  
Amy Myers Jaffe (co-PI), University of California, Davis  
Lew Fulton, University of California, Davis  
Rosa Dominguez-Faus, University of California, Davis  
Marshall Miller, University of California, Davis  
Hengbing Zhao, University of California, Davis  
Guozhen Li, University of California, Davis  
Raphael Isaac, University of California, Davis  
Paul Gruber, University of California, Davis



National Center  
for Sustainable  
Transportation

**UCDAVIS**

**SUSTAINABLE TRANSPORTATION ENERGY PATHWAYS**

*of the Institute of Transportation Studies*



## **About the National Center for Sustainable Transportation**

The National Center for Sustainable Transportation is a consortium of leading universities committed to advancing an environmentally sustainable transportation system through cutting-edge research, direct policy engagement, and education of our future leaders. Consortium members include: University of California, Davis; University of California, Riverside; University of Southern California; California State University, Long Beach; Georgia Institute of Technology; and University of Vermont. More information can be found at: [ncst.ucdavis.edu](http://ncst.ucdavis.edu).

## **U.S. Department of Transportation (USDOT) Disclaimer**

The contents of this report reflect the views of the authors, who are responsible for the facts and the accuracy of the information presented herein. This document is disseminated under the sponsorship of the United States Department of Transportation's University Transportation Centers program, in the interest of information exchange. The U.S. Government assumes no liability for the contents or use thereof.

## **UC Davis Disclaimer**

The primary purpose of this report is to summarize insights from the September 17, 2015 workshop. Therefore, the views and recommendations expressed by workshop participants, and detailed in this report, do not necessarily reflect the views of the UC Davis research team.

## **California Energy Commission Disclaimer**

This report was prepared as the result of work sponsored by the California Energy Commission. It does not necessarily represent the views of the Energy Commission, its employees or the State of California. The Energy Commission, the State of California, its employees, contractors and subcontractors make no warrant, express or implied, and assume no legal liability for the information in this report; nor does any party represent that the uses of this information will not infringe upon privately owned rights. This report has not been approved or disapproved by the California Energy Commission nor has the California Energy Commission passed upon the accuracy or adequacy of the information in this report.

## **Acknowledgments**

This study was funded by a grant from the National Center for Sustainable Transportation (NCST), supported by USDOT through the University Transportation Centers program. The authors would like to thank the NCST and USDOT for their support of university-based research in transportation, and especially for the funding provided in support of this project.



# **Biofuels Commercialization, Technology, Emerging Markets, and Government Policies**

**Report for the California Energy Commission  
Workshop, “Assessment of Critical Barriers and  
Opportunities to Accelerate Biofuels and Biomethane  
as Transportation Fuels in California”  
– September 17, 2015 at UC Davis**

---

A National Center for Sustainable Transportation Research Workshop Report

May 2016

**Sustainable Transportation Energy Pathways Program, Institute of Transportation Studies,  
University of California, Davis**

Andrew Burke (co-PI)

Amy Myers Jaffe (co-PI)

Lew Fulton

Rosa Dominguez-Faus

Marshall Miller

Hengbing Zhao

Guozhen Li

Raphael Isaac

Paul Gruber



[page left intentionally blank]

# TABLE OF CONTENTS

EXECUTIVE SUMMARY .....	i
1. Purpose and objectives of the Workshop.....	1
2. Summaries of the general findings of the Workshop .....	2
2.1 Status (2015) of biofuels markets and technology .....	2
2.2 Critical barriers for commercialization of biofuels.....	3
2.3 Ideas and solutions to overcome the barriers .....	6
3. Findings of Session #1; setting the stage: Status (2015) of biofuels markets.....	12
3.1 Quantities of fossil fuels used in 2014-15 .....	12
3.2 Biodiesel and renewable diesel .....	13
3.3 Biomethane.....	17
3.4 Drop-in hydrocarbon fuels .....	34
3.5 Feedstocks for various biofuels .....	43
4. Findings for Session #2: Critical barriers for commercialization of biofuels and biomethane .....	50
4.1 Capital and R&D funding is uncertainty .....	50
4.2 Uncertainty in Government policies and regulations .....	51
4.3 Uncertainty in feedstock availability, source, and cost.....	53
4.4 Barriers for drop-in liquid fuels.....	53
4.5 Barriers for renewable natural gas .....	55
5. Finds for Session #3: Ideas and solutions to overcome barriers .....	57
5.1 Ways to maintain continuity of government regulations, incentives, and R&D funding.....	57
5.2 Ways to structure incentives and government policies to accelerate improvements in technology, scale-up of projects, and feedstock availability and flexibility .....	57
5.3 Ways to improve the business climate for biofuel commercialization by increasing private investment, oil industry involvement, and general economic profitability .....	59
5.4 Ways to improve the carbon intensity and long-term availability of feedstocks for low carbon fuels .....	60
5.5 Ways to accelerate the development of technology for biofuels, especially drop-in bio-gasoline and diesel, from cellulosic feedstocks .....	62
5.6 Ways to increase customer demand for biofuels to enhance investments in infrastructure and vehicles that can use biofuels.....	63
6. References.....	64
Appendix I: Workshop Agenda and Attendees .....	67
Appendix II: Participants' Comments .....	74

# Biofuels Commercialization, Technology, Emerging Markets, and Government Policies

## EXECUTIVE SUMMARY

The University of California Davis and the California Energy Commission held a workshop, *“Assessment of Critical Barriers and Opportunities to Accelerate Biofuels and Biomethane as Transportation Fuels in California,”* at UC Davis on September 17, 2015. This report summarizes the findings and recommendations of the workshop and related backup materials concerned with the status of biofuels technologies, current and projected markets for biofuels, and government policies and regulations.

At the present time, the primary biofuels being marketed in the U.S. are corn-derived ethanol blended with gasoline (15 bg/y) and soy-bean derived FAME biodiesel blended with standard diesel fuel (2 bg/y). This represents about 10% of gasoline sales and 5% of diesel sales in the U.S. The other biofuel currently being produced in significant quantities (2.3 bgge/y) is renewable natural gas (biomethane), which is primarily used, in the same location that it is produced, to generate electricity. The size of the markets for these biofuels is determined primarily by two major government policies, the Federal RFS (renewable fuel standard) and the California LCFS (low carbon fuel standard), both of which are expected to become more stringent in future years.

Currently most biofuels are produced from corn (ethanol), soy bean and waste vegetable oils (biodiesel), and landfills and organic waste (biomethane). In 2014, less than one-half of the biodiesel was produced from waste vegetable oils. The feedstocks for liquid fuels are either of limited quantity or do not have an ultra-low carbon intensity. Their carbon intensity is greater than 30 (CI). Most future quantities of biofuels will need to be produced from cellulosic feedstocks to meet future RFS and LCFS regulations. The technologies to produce cellulosic ethanol, drop-in gasoline, renewable diesel, and renewable natural gas from cellulosic feedstocks are now under development with pre-commercialization levels of production, but they have not achieved a level of commercial readiness for large scale production. There is considerable uncertainty as to whether the many millions of metric tons required annually of the cellulosic feedstocks to fulfill U.S. Policy targets can become available. Other barriers to large scale production of biofuels include uncertainties in government policies and the need for long-term commitments, limited government funding for R&D and pilot production, and the need for large, risky capital investments for the scale-up of the technologies needed to produce billions of gge/yr of each of the biofuels. All of these uncertainties, or barriers, were discussed at the workshop and possible approaches, or solutions, to overcome them were identified and discussed.

## STATUS (2015) OF THE BIOFUELS MARKETS AND TECHNOLOGIES

The first purpose of the workshop was to summarize the status of biofuels markets and technologies in California. This status, as of Fall 2015, for U.S. and California biofuels markets is summarized as follows:

**Ethanol** – About 15 billion gallons of ethanol was used in the U.S. in 2014, nearly all produced from corn kernels. The volume of ethanol used is directly related to the 10% limit set for blending with gasoline. Very little ethanol was produced from cellulosic feedstock in 2014. California used 1.6 billion gallons of ethanol in 2014, but produced only 0.22 billion gallons.

**Biodiesel (FAME-Fatty Acid Methyl Ester)** – The U.S. produced 1.8 billion gallons of biodiesel in 2014, mostly from soy bean and waste oil feedstocks. About 1/3 of the biodiesel was made from waste vegetable oils. Biodiesel's chemical composition is not the same as conventional diesel, so it is used only in blends with the conventional fuel. The blends are B5 and B20 with only blends of less than B5 being called diesel fuel. Blends up to B20 can be used without engine modification, but vehicle performance and emissions are degraded. California produced 65 million gallons in 2014.

**Renewable diesel** – Most of the renewable diesel used in the U.S. is imported from South East Asia, especially from Singapore. The volume of the imports varies between 0.12 and 0.2 billion gallons per year. The chemical composition and combustion characteristics of renewable diesel are close to those of conventional fossil-based diesel fuel. Blending of renewable diesel with conventional diesel fuel is not necessary, and RD100 can be used in conventional diesel engines and infrastructure without restrictions. California currently produces a very small volume of renewable diesel fuel.

**Drop-in gasoline** – There is essentially no commercial production of drop-in gasoline or aviation jet fuel produced from biomass in the U.S. There are a small number of R&D and demonstration projects underway that produce small amounts of fuel from woody feedstocks.

**Biomethane** – Biogas is produced by the anaerobic digestion of organic wastes and from natural processes occurring in landfills. Biogas is a mixture of methane, CO<sub>2</sub>, and other trace elements. Recovery of the methane from biogas is a critical step to the marketing of biomethane. Biomethane can be injected into commercial natural gas pipelines if its heat value is close to that of natural gas (1000 Btu/scf). An NREL study in 2012 estimated that about 420 billion scf of biomethane could be produced in the U.S. from various forms of organic waste and landfills. This is 5% of the natural gas used to generate electrical power, or 56% of natural gas used in transportation. The California Biomass Collaborative estimated in 2013 that California could produce 93 billion scf of biogas. Hence, the energy content of biomethane is relatively small compared to the present uses of natural gas. The price of biomethane is much higher than natural gas (by a factor of about 2) primarily due to the need to clean the biogas. There is, however, considerable local use of biogas to generate electrical power and heat on farms and

at waste water treatment facilities.

**Feedstock to produce biofuels** – Many millions of dry metric tons of feedstock per year are required to produce each of the biofuels in volumes of billions of gallons per year. For example, about 15 million metric tons are needed to produce one billion gallons gasoline-equivalent (bgge) in the cases of ethanol, biodiesel, renewable diesel, or drop-in gasoline (the exact amount for each biofuel depends on the conversion efficiency for the fuel production process). Potential supplies of feedstocks are large, but only a small fraction of the potential supply is expected to be available to produce biofuels. This is because of competing options for use of the resources to produce the feedstock and logistics for its collection and transportation. In the case of California in 2014, the technically feasible supply estimated by the California Biomass Collaborative is 80 million metric tons, but the currently available supply is estimated to be only 30 million metric tons for all biofuels combined. Hence it appears that biofuel production in California is currently feedstock constrained, which would need to change in the future to reach the technical potential. The California Biomass Collaborative estimated that the state only has about 80 million tons of feedstock potentially available for all biofuel production at the present time.

## **CRITICAL BARRIERS FOR COMMERCIALIZATION OF BIOFUELS**

The workshop identified a number of critical barriers to the commercialization of biofuels. The most important of those barriers are the following:

**Technical and economic uncertainty** - The uncertainty that a technology for producing biofuels is efficient, reliable and economically viable is one of the barriers for successful commercialization. It is necessary to *maintain* adequate funding during the demonstration and early production stages of development of the technology. These stages require years and funding agencies and investors can become impatient and stop funding projects when progress appears to be slow. The long development timelines required also make it difficult to get a significant ROI on these types of projects. Scaling up the manufacturing processes for large scale production is very expensive, requiring large capital investments. This is a major final barrier unless the final scale-up is done by an energy company with large profits to invest in future products.

**Uncertainty in government policies and regulations** - The number one barrier to investment in biofuels, discussed by stakeholders at the workshop, was policy uncertainty, particularly how long a policy might remain in effect. These policies included the following:

- EPA National RFS (Renewable Fuel Standard)
- California LCFS (Low Carbon Fuel Standard) post-2020
- California Cap-and-trade eligibility

In the case of renewable natural gas (RNG) transportation fuel projects, uncertainty of the duration of RFS2 and California LCFS programs resulted in the obligated parties' unwillingness

to commit to firm pricing for purchase of RNG. Policy uncertainties affect revenue predictability, and hence profitability, for all biofuels projects.

**Uncertainty in feedstock availability, source, and cost** - Various workshop attendees noted that biofuel production faces uncertainties in both the supply and cost of feedstocks. Attendees cited the importance of “BCAP” (Biomass Crop Assistance Program, <http://www.fsa.usda.gov/programs-and-services/energy-programs/BCAP/index>) type programs that financially assist “owners and operators of agricultural and non-industrial private forest land who wish to establish, produce, and deliver biomass feedstocks” (USDA, 2015) especially cellulosic feedstock. Near-term feedstock barriers also include the scale and logistics of managing feedstock, which is generally sparsely distributed. Hence there is need for a logistics infrastructure that combines biomass processing and concentration of feedstock streams to enable increasing scale of biomass facilities.

**Lack of progress in developing technologies for drop-in liquid fuels from biomass** - Currently gasoline is the end-use fuel used in the greatest quantity, followed by diesel. Hence, replacing gasoline in the current road fleet with a drop-in biomass based fuel would be the fastest way to reduce GHGs for the current fleet. There are a number of companies and projects underway in the U.S. and Europe to develop technologies to produce drop-in gasoline from cellulosic biomass. However, progress in those developments has been slow, and the cost of moving from laboratory pilot hardware systems to demonstration scale systems is high and relatively risky. Consequently, at the present time, there are no commercial scale drop-in gasoline facilities in operation and none seem to be planned for the near-future. The development of facilities to produce biomass based gasoline has been slow and will likely continue to be slow in the near future.

#### **Barriers to commercialization of biomethane (renewable natural gas, or RNG)**

Key barriers to the commercialization of RNG are the low cost of fossil natural gas and the uncertainty of RINS and LCFS credits. These barriers are particularly important, because the cost of producing RNG is relatively high due in large part to the need to remove CO<sub>2</sub> and other impurities from the biogas. This makes it difficult for RNG to penetrate the fossil natural gas market and even more difficult to compete with diesel fuel for trucks. There was general consensus among stakeholders at the workshop that rules recommended by major Californian utilities concerning the properties of RNG to be injected into the pipeline make it difficult to commercialize it. According to the stakeholders, these rules are more stringent than for conventional natural gas, restrict sale of RNG to nearby consumers, and should be relaxed.

#### **IDEAS AND SOLUTIONS TO OVERCOME THE BARRIERS**

##### **Ways to maintain continuity of government regulations, incentives, and R&D funding**

As expressed by several workshop participants, a key issue is that state and federal governments do not make a clear, continuing, long-term commitment to the commercialization of biofuels as a critical means of reducing GHGs from vehicles of various types. The regulations



and incentives put in place should be structured such that their effectiveness is independent of the price of fossil energy, in particular oil. Regulations and incentives should function, according to stakeholders, such that the development of biofuel technology and sale of biofuels does not ebb and flow in response to free market forces (i.e., fossil energy prices). As stated by stakeholders at the workshop:

- The regulations and incentives should reflect primarily the need for progress in reducing GHGs and hence be in place for long periods of time (10-20 years) without the possibility, or fear, of cancelation or significant weakening.
- The regulations should be coordinated so that complying with regulations from one agency is not made more difficult or less effective due to regulations from another agency.
- It was suggested at the workshop that a high level task force be set up in California to coordinate all the state regulations related to GHG reduction.
- Government R&D funding should be concentrated on projects that, if successful, would attract private funding for the demonstration and commercialization stages.
- More diligent vetting of new projects is key so that projects of little chance of success or minimal importance are not funded.

### **Ways to structure incentives and government policies to accelerate improvements in technology, scale-up of projects, and feedstock availability and flexibility**

The discussion of government incentives and policies at the workshop covered a broad range of issues. The most important issue was consistency of funding and regulatory programs. Without having significant consistency in incentives and policies, industry often struggles to receive private investment and meet regulatory compliance. The following are ideas expressed by workshop participants, summarized by the UC Davis team:

#### **Grants and Incentives**

AB 1826 based incentives help secure feedstock and increase tipping fees that strongly affect the economics of a project. Presently, enforcement of the AB 1826 requirements, according to assembled workshop stakeholders, is not clear and should be strengthened. CEC grant funding, according to stakeholders, should focus on R&D and demonstrations of high risk, but high (potentially) effective, technologies that are not yet economically attractive. Funds must be distributed in a timely manner in order not to adversely affect project progress and scheduling. There was also general consensus among stakeholders that the CEC AB118/AB8 funding fills an important, needed gap in the commercialization spectrum for alternative fuels and vehicles in California.

CalRecycle loans and grant funding [Recycling Market Development Zones (RMDZ) program] provides low interest loans for anaerobic digestion projects. Funding release has been slowed by legislative action. Stakeholders stated that the funding must be made available when expected so projects can be properly planned and funds used most effectively.

RINS and LCFS credits can add revenue to projects to make them more economically attractive. Financial partners often do not include these credits when they evaluate projects for funding because the future of these credits is uncertain and the credit pricing fluctuates significantly. Stakeholders stated repeatedly that, in order to help companies secure financial partner funding, RINS and LCFS credits should be fixed long term through the legislation. The availability and pricing should be fixed for periods of at least 10 years.

There are tax incentives for electricity but not for transportation fuels. Hence stakeholders stated that biofuel technology applications tend to move toward electricity rather than to transportation. Assuming the need to shift to more biofuels in transportation to help achieve environmental or other goals, there should be tax incentives for renewable transportation fuels.

The CEC's Alternative and Renewable Fuel & Vehicle Technology program (ARFVTP) allocates \$100 million per year to advance the early commercialization of alternative fuels and vehicles in California. Of this total, \$20 million per year is made available to advance biofuels production and supply, but according to workshop participants this allocation is not enough, as biofuels produce the majority of program benefits and generate most of the LCFS credits. A biofuels funding initiative, which would include an in-state production incentive and infrastructure expansion, was proposed at the workshop and was widely supported. Legislative action in this area may be starting, with several assembly and senate bills using funding from the Greenhouse Gas Reduction Fund (GGRF) which is from Cap-and-Trade allowance auction proceeds. These funds are only now becoming available, but they would be a significant source looking forward with \$25 million in funding becoming available for biofuels projects during the current year due to efforts by the California Biofuels Cap and Trade Initiative. Additional funding of \$40 million may also be available from the California Air Resources Board during the current year. Funds could be allocated based on CalEnviroScreen scoring to provide more support towards disadvantaged communities.

State and federal funding is not well integrated with private capital, according to stakeholders. Mechanisms could be, in the view of workshop participants, put in place to leverage public funding to create synergies between the two. Government funding agencies should work with private funders to identify opportunities, vet technologies, and oversee management to enhance the effectiveness of the funding.

### **Other Government Policies**

Stakeholders agreed that it is critical to have consistent, strong, reliable, and coordinated government policies to send the message to industry that they can rely on these policies when planning projects.

Compliance policies should be coordinated across all relevant agencies. For example, the Clean Air Act and the California Environmental Quality Act (CEQA) require agencies to identify the

significant environmental impacts of projects and to ensure that negative impacts are avoided or mitigated.

Building codes, program rules, and reporting requirements are often changed too frequently and can make compliance extremely difficult. One possible solution to coordinating and producing more consistent government policies is the creation of a high-level biofuels task force. The task force would interact with all relevant government agencies which oversee environmental policies and help to eliminate barriers between these agencies. Industry participation on the taskforce would be imperative.

Stakeholders stated that infrastructure must be developed to work well with the existing transportation fuels industry. Since most renewable transportation fuel (e.g. renewable diesel and RNG) is blended with fossil fuels, to increase renewable fuel blending stakeholders suggested that government should invest in storage and blending infrastructure. They also stated that government should work with the existing petroleum and natural gas industries to find solutions to the barriers to blending.

The EPA consistently sets renewable fuel requirements well below total capacity, according to stakeholders; the requirements should be set close to what the industry can actually provide, including biofuel reserves. The California LCFS is performance based, but the RFS is not. In many stakeholders' view, the RFS should be changed to be based on performance.

### **Ways to improve the business climate for biofuel commercialization by increasing private investment, oil industry involvement, and general economic profitability**

The following recommendations to improve the business climate for biofuels were suggested by invited speakers and discussants at the workshop.

- California state agencies could guarantee 90% of RNG project asset-secured debt (whether bonds or commercial debt) with a term of 15 years (including up to 2 years of construction and 13 year amortization) used to finance up to 80% of capital expenditures and related debt costs. A projected Debt Service Coverage Ratio of 1.2:1 would be required to qualify for state agency guarantee. The state credit rating could be made available to RNG projects without immediate, or perhaps any, use of tax dollars.
- Obligated parties under the LCFS must be willing to enter into a 15 year RNG Purchase Agreement with a formula for pricing RINS and LCFS credits (as opposed to fixed price) and with a "regulatory out" if the RFS2 program or the LCFS credits program terminates.
- Loan guarantees should support RNG projects that meet California objectives of reducing the number of diesel vehicles on road and the adoption of alternative fueled vehicles, such as CNG/LNG.
- Greater state support, including cap-and-trade auction revenue, is needed to benefit in-state California biofuel production.
- Financial incentives for incumbent companies should be offered to encourage them to

sell biofuels.

- Financial support should be offered to promote improved access and production of in-state bio-mass feedstock.

### **Ways to reduce the carbon intensity and increase the long-term availability of affordable feedstocks for low carbon fuels**

It is important to have a rational, transparent approach to determining the carbon intensity of feedstock and biofuels that is applicable as technologies and policies change. This will improve both the reliability of carbon intensity estimates and the availability of feedstock.

One approach to determining the carbon intensity of biogas and biofuels is investigating the 'counterfactual' – that is, what would be the result if no biofuel/biogas was produced versus what would be the result if it were produced. This comparison should include consideration of alternate uses of the relevant feedstock when that is appropriate. Taking the example of biomethane, applying the counterfactual approach can make the carbon intensity of biogas negative. If no biogas were collected, carbon would leak to the atmosphere from decaying biomass. By creating the biogas pathways, this carbon is collected and put to useful work as a fuel. The counterfactual approach for forest and agricultural residue-sourced biogas is either rotting dead wood or agricultural residues left to decompose or be burned. These residues can be collected and processed using thermochemical processes (gasification) to produce biogas. If these residues are used to produce biofuels, the same counterfactual approach can be applied. An aspect that should be considered in the fuel carbon intensity determination is the ratio of energy-input to energy output ( $E_i:E_o$ ) of the processes involved. Lower ratios are better. The ratio is dependent on 1) the mechanization of the planting and harvest of the crop and how much chemical fertilizer is needed, 2) the biomass yield, and 3) the biofuel yield. Minimizing the first and maximizing the second and third will improve the  $E_i:E_o$  ratio. This is why sugarcane ethanol from Brazil has significantly lower carbon intensity than American corn ethanol.

In summary, the lowest carbon intensity biogas/biofuels will be produced from wastes. For non-waste feedstocks, it is important to minimize land use change that result in a net release of carbon. Finally, for any feedstock/biofuel/biogas case, inefficiencies should be reduced in each conversion step, because conversion yields are the normalizing factor in the estimation of the carbon intensity.

### **Ways to accelerate the development of technology for biofuels, especially drop-in bio-gasoline and diesel, from cellulosic feedstocks**

The development of technology to produce drop-in, hydrocarbon biofuels has been slow, and at the present time there is no significant production of drop-in gasoline or aviation jet fuel. There is significant production of drop-in diesel fuel, but it is primarily produced from soybean and other oils, which are not ideal feedstocks for future, large scale, sustainable fuel production. In order to establish large scale production capability (many bgge/yr), it is necessary to develop cost-effective technologies for producing hydrocarbon, biofuels and very

large, sustainable sources (many million metric tons/yr) of cellulosic feedstock. Neither of these requirements is currently close to being met. Development of the production technology will require large R&D and capital investments over long periods of time (> 10 years). This will result only if there is a national commitment to replace fossil-based fuels for vehicles with biofuels that is evident from regulations and fuel and price incentives that will remain in place for at least 10 years. This commitment could encourage the large oil companies to get re-involved with biofuel production and marketing.

Providing the large scale, sustainable feedstock supply will require state and national, coordinated programs that will organize both the production and gathering of the cellulosic feedstocks needed. These feedstocks must be low carbon intensity to satisfy the LCFS and RFS requirements, which will become more demanding in future years. Financial incentives for both capital investments in technology R&D and to feedstock suppliers will be necessary over many years. This will be possible only if the U.S. makes a firm commitment to replace a significant fraction of its fossil-based fuels with sustainable, biofuels.

### **Ways to increase customer demand for biofuels to enhance investments in infrastructure and vehicles that can use biofuels**

There are two ways to have high demand for biofuels. One way is to require, through regulation, blends of biofuels with fossil-based fuels, as in the case of gasoline and ethanol. The demand for ethanol would increase significantly if the blend fraction was increased from 10% to 15%. The second way is to have the price of the biofuel to the consumer be lower than the competitive fossil-based fuel. This is the approach taken in Brazil to promote the use of sugarcane based ethanol. Vehicles sold in Brazil are required to have bi-fuel capability. The biofuel is kept competitive by varying the tax on the different fuels as the price of oil changes. Government policies could be used in the U.S. to influence the use of biofuels in vehicles. Cost aside, consumers must be assured that the use of a biofuel will not damage the engine in their vehicle or negate the vehicle warranties. According to one workshop participant, some of the federal labeling of biofuels is more restrictive than warranted based on actual engine performance tests. Hence, the labeling should be re-evaluated so as to not to discourage consumers un-necessarily from using biofuels. Stakeholders at the workshop noted that the California Air Resources Board has not encouraged the use of biofuels as strongly as it has other alternatives such as EVs and fuel cell vehicles. Large incentives to buyers of EVs has increased demand for those vehicles. On the other hand, biofuels not only lack those incentives, but the national blend wall has also limited the fuels' penetration into the market. One participant at the workshop suggested that setting minimum quotas for a certain percentage of flex fuel vehicles sold by manufacturers could also stimulate demand. This would increase ethanol demand if the price of E85 on an energy basis was less than gasoline.

## 1. Purpose and objectives of the Workshop

Both the U.S. and California have made commitments to achieve an 80% reduction in energy-related greenhouse gases (GHGs) from 1990 levels by 2050, in order to help stabilize atmospheric concentrations of GHGs. Governor Brown of California, this past summer, made additional commitments to achieve up to 50% reduction in petroleum usage in vehicles by 2030. In addition to electricity, hydrogen, and natural gas in some cases, biofuels are a necessary, but challenging, element of a sustainable transportation portfolio in most world regions, including California. In very low carbon fuel mix scenarios developed by UC Davis, the California Air Resources Board, and others, use of biofuels would need to grow considerably, displacing petroleum-based transportation fuels by up to one third in the year 2050 in order for GHG goals to be met by that date (Yang, 2015). The recent STEPS White Paper described biofuels potential role and challenges as follows:

“Large quantities of low carbon fuels will likely be needed to meet the world’s increasing levels of travel and need to achieve climate change goals. For example, electricity and hydrogen appear to be potentially attractive fuels for light duty vehicles, but these energy carriers may not be suitable for aviation, shipping or long haul trucking. Biofuels made from non-food sources such as agricultural, municipal, and forest waste, high yielding cellulosic crops, and algae are potentially important low carbon liquid fuel options. Despite billions of dollars invested over the last decade in these advanced biofuels, the jump from labs and small demonstrations to commercial-scale operations is proceeding slowly. Progress is being made, however, at many existing commercial biorefineries to incrementally lower the carbon intensity of fuels; these facilities are improving efficiencies and adding new process fuels, as well as expanding into small scale cellulosic production using existing infrastructure and feedstock supply logistics.” (Fulton et al, NextSTEPS White Paper: Three Routes Forward for Biofuels – Incremental, Transitional, and Leapfrog, 2014).

To achieve lower-carbon trucking in California and the US (e.g., an “80-in-50” target, or 80% reduction in GHGs by 2050 compared to a 1990 baseline) Fulton et al (2015) produced scenarios including electricity, hydrogen and biofuels that indicated that “a combination of strong uptake of zero-emission trucks and advanced biofuels will likely be needed to hit such a target, but even with this combination, meeting the target will be very challenging.”

The UC Davis Institute of Transportation Studies (ITS-Davis) and the California Energy Commission (CEC) conducted joint workshops on September 17-18, 2015 to seek and discuss insights on the growth of biofuels and biomethane in California, progress achieved to date, critical barriers, and requirements needed to boost commercialization. The workshops were held at UC Davis on September 17, 2015 and at the CEC on September 18, 2015.

This document summarizes recent UC Davis research insights on commercialization of biofuels in California and insights from the September 17 workshop at UC Davis, in which over 100 stakeholders (see Appendix I) from industry, government and academia discussed the status of biofuels in California, highlighted critical barriers to commercialization, and recommended

actions to maximize and accelerate commercialization.

The September 17 workshop was the first in a series of three workshops, funded by the CEC and through the National Center for Sustainable Transportation, aimed at assessing critical barriers to commercialization for alternative fuel and vehicles technologies in California. The objective of this CEC-funded research is to “identify environmentally and economically promising alternative fuel and vehicle emerging technologies, and to identify and evaluate the critical business and policy barriers blocking their widespread adoption in the state and actionable solutions to overcome those barriers. Through this subtask we seek to analyze the broad range of commercial barriers and identify strategies to increase the adoption and rapid scale-up of emerging technologies, fuels and fueling infrastructure that will help the state achieve its AB118 targets and goals for air quality and greenhouse gas emissions” (excerpted from UC Davis Statement of Work, CEC Agreement ARV-13-020).

## 2. Summaries of the general findings of the Workshop

### 2.1 Status (2015) of biofuels markets and technology

#### 2.1.1 Status of the markets

**Ethanol** – About 15 billion gallons of ethanol was used in the U.S. in 2014, nearly all produced from corn kernels. The volume of ethanol used is directly related to the 10% limit set for blending with gasoline. Very little ethanol was produced from cellulosic feedstock in 2014. California used 1.6 billion gallons of ethanol in 2014, but produced only 0.22 billion gallons.

**Biodiesel (FAME)** – The U.S. produced 1.8 billion gallons of biodiesel in 2014, most produced from soy bean and waste vegetable oil feedstocks. About 1/3 was produced from waste vegetable oils in 2014. Biodiesel’s chemical composition is not the same as conventional diesel, so it is used only in blends with the conventional fuel. The blends are B5 and B20 with only blends of less than B5 being called diesel fuel. Blends up to B20 can be used without engine modification, but vehicle performance and emissions are degraded.

**Renewable diesel** – Most of the renewable diesel used in the U.S. is imported from South East Asia especially from Singapore. The volume of the imports vary between 0.12 and 0.2 billion gallons per year. The chemical composition and combustion characteristics of renewable diesel are close to those of conventional fossil-based diesel fuel. Renewable diesel is produced by hydroprocessing at elevated temperature and pressure. The feedstock used is essentially the same as for biodiesel. Blending of renewable diesel with conventional diesel fuel is not necessary, and B100 can be used in conventional diesel engines without restrictions. Bio-diesels produced from cellulosic feedstocks are considered renewable. California currently produces a very small volume of renewable diesel fuel.

**Drop-in gasoline** – There is essentially no commercial production of drop-in gasoline or aviation

jet fuel produced from biomass in the U.S. There are a small number of R&D and demonstration projects underway that produce small amounts of fuel from woody feedstocks.

**Biomethane** – At the present time, biogas is produced by the anaerobic digestion of organic wastes and from natural processes occurring in landfills. Biogas is a mixture of methane, CO<sub>2</sub>, and other trace elements. Recovery of the methane from biogas is a critical next step to the marketing of biomethane. Biomethane can be injected into commercial natural gas pipelines if its heat value is close to that of natural gas (1000 Btu/scf). An NREL study in 2012 estimated that about 420 billion scf of biomethane could be produced in the U.S. from various forms of organic waste and landfills. This is 5% of the natural gas used to generate electrical power, or 56% of natural gas used in transportation. Hence, the energy content of biomethane is relatively small compared to the present uses of natural gas. The price of biomethane is much higher than natural gas (by a factor of about 2) primarily due to the need to clean the biogas. There is, however, considerable local use of biogas to generate electrical power and heat on farms and at waste water treatment facilities.

**Feedstock to produce biofuels** – Many millions of dry metric tons of feedstock per year are required to produce each of the biofuels in volumes of billions of gallons per year. For example, about 15 million metric tons are needed to produce one billion gallons gasoline-equivalent (bgge) in the cases of ethanol, biodiesel, renewable diesel, or drop-in gasoline. Potential supplies of feedstocks are large, but only a small fraction of the potential supply is expected to be available to produce biofuels. This is because of competing options for use of the resources to produce the feedstock and logistics for its collection and transportation. In the case of California in 2014, the technically feasible supply estimated by the California Biomass Consortium is 80 million metric tons, but the currently available supply is estimated to be only 30 million metric tons for all biofuels combined. Hence it appears that biofuel production in California is currently feedstock constrained, which would need to change in the future to reach the technical potential.

## 2.2 Critical barriers for commercialization of biofuels

### 2.2.1 Capital and R&D funding

The uncertainty that a technology for producing biofuels will be efficient and economically viable is one of the barriers for successful commercialization. Maintaining adequate funding during the R&D and the pilot production stages is particularly difficult. These stages can require a number of years and funding agencies and investors can become impatient when progress appears to be slow and difficult for them to assess. Scaling up the manufacturing processes for large scale production is very expensive, requiring large capital investments. This is a major final barrier unless the final scale-up is done by an energy company with large profits to invest in future products.

Biofuel and biomethane projects seem to be lacking in funding at the present time. Investors seem to deem biofuel and biomethane projects as riskier than typical investments for several



reasons. One reason for this perception is that most of the oil companies, who are making large profits and have large profits to reinvest do not see the need for biofuels development and continue to make their investments in more conventional energy resources. State and federal funding can be adequate for R&D and small pilot demonstration projects but are usually inadequate for scale-up to large scale production volumes needed to attain biofuel prices competitive with fossil-based fuels.

### *2.2.2 Uncertainty in government policies and regulations*

The number one barrier to investment in biofuels, as discussed at the Sept. 17 workshop, is policy uncertainty, particularly how long a policy might remain in effect. Uncertainties from multiple levels of government were presented by academic speakers at the workshop (e.g., Elkind, 2015):

- EPA RFS (Renewable Fuel Standard)
- LCFS (Low Carbon Fuel Standard) post 2020
- Cap-and-trade eligibility

Other speakers at the workshop (e.g., Williams, 2015) provided additional insights from the industry's perspective. In renewable natural gas (RNG) transportation fuel projects, uncertainty of the duration of RFS2 and California LCFS programs resulted in the obligated parties' unwillingness to commit to firm pricing for purchase of RNG, since the value of Renewable Identification Numbers (RINS) and LCFS credits beyond 2022 are uncertain. A short duration RNG Sales Agreement with unpredictable pricing will not support the needed project finance debt for RNG projects or any other, large biofuels projects. Policy uncertainties affect revenue predictability, and hence profitability, for biofuels projects.

### *2.2.3 Uncertainty in feedstock availability, source, and cost*

Various workshop attendees noted that biofuel production faces uncertainties in both the supply and cost of feedstocks. Attendees cited the need for more "BCAP" (Biomass Crop Assistance Program, <http://www.fsa.usda.gov/programs-and-services/energy-programs/BCAP/index>) type programs to financially assist "owners and operators of agricultural and non-industrial private forest land who wish to establish, produce, and deliver biomass feedstocks" (USDA, 2015) especially cellulosic feedstock. Near-term feedstock barriers also are concerned with the scale and logistics of managing feedstock. Biomass is generally sparsely distributed, and biomass facilities are often small in scale, in contrast to concentrated and large refineries that produce gasoline. Hence, there is need for a logistics infrastructure that combines biomass processing streams, concentration of feedstocks, and other steps to enable increasing facility scales as more concentrated energy streams become available.

### *2.2.4 Barriers for the development of drop-in liquid fuels*

Currently gasoline is the end-use fuel used in the greatest quantity, followed by diesel. Hence, replacing gasoline in the current road fleet with a drop-in biomass based fuel would be the

fastest way to reduce GHGs for the current fleet. Further, understanding the barriers to the development of technologies to produce and market drop-in gasoline from biomass should have a high priority, according to workshop participants. Producing a drop-in diesel fuel appears to be less difficult/expensive than a drop-in gasoline fuel.

There are a number of companies and projects underway in the U.S. and Europe to develop technology to produce drop-in gasoline from cellulosic biomass. However, progress in those developments has been slow, and the cost of moving from laboratory pilot hardware systems to demonstration scale systems is high and relatively risky. The costs of scale-up from pilot to demonstration, and then especially to commercial scale, can be very expensive. In addition to cost, the risks of failure are high due to the high pressure and temperature of the processes and the need for the use of high cost catalysts, which can have limited life under these operating conditions. Consequently, at the present time, there are no commercial scale drop-in gasoline facilities in operation and none seem to be planned for the near-future. The development of facilities to produce biomass based gasoline has been slow and likely will continue to be slow in the near future.

A related issue is the blending of ethanol with gasoline. Ethanol is the most available blendable fuel for light-duty vehicles. Currently nearly all gasoline sold in California and the U.S. contains 10% ethanol. Nearly all of this ethanol is produced from corn, which limits the GHG reduction of this ethanol in gasoline. The total ethanol used currently is limited by the 10% “blend wall”. The blending limit could be raised to 15% if there could be agreement on it with the auto industry and other stakeholders. More ethanol could also be used if there were a larger market for E85 for use in flex-fuel vehicles.

Another barrier to the use of ethanol to reduce GHG is that most of the ethanol is produced from corn kernels rather than cellulosic bio-materials. The reasons for this include the competitive advantage of corn ethanol, the slow development of processes for the commercial scale production of ethanol from cellulosic materials, and the current high cost of cellulosic ethanol.

### *2.2.5 Barriers for renewable natural gas*

Barriers to the commercialization of RNG are the low cost of fossil natural gas, with which renewable gas must compete, and the uncertainty of RINS and LCFS credits. Another factor that affects profitability is the large variability of tipping fees for solid waste disposal. The cost of producing RNG is relatively high due in large part to the need to remove CO<sub>2</sub> and impurities from the biogas. This makes it difficult for RNG to penetrate the fossil natural gas market and even more difficult to compete with diesel fuel for trucks.

Access to market is key for RNG. There was general, and fairly vehement, consensus among stakeholders who attended the September 17 workshop that rules recommended by major California utilities (i.e., PG&E and SoCalGas) make it difficult for RNG to be injected into the pipeline. According to stakeholders, these rules limit the sale of RNG to only nearby

consumers. These rules are a key barrier to the large scale commercialization of RNG and should be relaxed.

## **2.3 Ideas and solutions to overcome the barriers**

### ***2.3.1 Ways to maintain continuity of government regulations, incentives, and R&D funding***

As expressed by several workshop participants, a key issue is that state and federal governments do not make a clear, continuing, long-term commitment to the commercialization of biofuels as a critical means of reducing GHGs from vehicles of various types. The regulations and incentives put in place should be structured such that their effectiveness is independent of the price of fossil energy, in particular oil. Regulations and incentives should function, according to stakeholders, such that the development of biofuel technology and sale of biofuels does not ebb and flow in response to free market forces (i.e., fossil energy prices). As stated by stakeholders at the workshop, the regulations and incentives should reflect primarily the need for progress in reducing GHGs and hence be in place for long periods of time (10-20 years) without the possibility, or fear, of cancelation or significant weakening. The regulations should be coordinated so that complying with regulations from one agency is not made more difficult or less effective due to regulations from another agency. It was suggested at the workshop that a high level task force be set up in California to coordinate all the state regulations related to GHG reduction.

Particular examples of what could be done are the following. At the Federal level, RFS alternative fuel requirements and related incentives and price supports, according to stakeholders, should be set to promote growth in the biofuels industries favoring those fuels thought to be most critical for GHG reductions. Any tax credits for biofuel development and related facilities should remain in place for 10-20 years (an adequate time period for the development of biofuels technologies). Government R&D funding should be concentrated on projects that, if successful, would attract private funding for the demonstration and commercialization stages. More diligent vetting of new projects is key so that projects of little chance of success or minimal importance are not funded.

Other key regulations are those related to the LCFS and information concerning the carbon intensity of various alternative fuels, feedstocks, production processes, and vehicle end uses. The fuel quantity targets and carbon intensity values set by California have a strong influence on projects undertaken and funded nationwide. Hence these targets and values should be set in a systematic manner over an extended period of years so that developers of biofuel technology and those that finance those developments can be confident that the ground rules will not change during the development. It is critical that the regulations related to the LCFS and the RFS are consistent and coordinated to support biofuels production in the long-term as well as in the short-term.

### *2.3.2 Ways to structure incentives and government policies to accelerate improvements in technology, scale-up of projects, and feedstock availability and flexibility*

The discussion of government incentives and policies at the workshop covered a broad range of issues. The most important issue was consistency of funding and regulatory programs. Without consistency industry can struggle to receive private investment and meet regulatory compliance. What can be done regarding incentives and regulations will be discussed separately.

#### **Incentives**

AB 1826 based incentives help secure feedstock and increase tipping fees that strongly affect the economics of a project. Presently enforcement of the AB 1826 requirements is not clear and should be strengthened.

CEC grant funding, according to stakeholders, should focus on R&D and demonstrations of high risk, but high (potentially) effective, technologies that are not yet economically attractive. Funds must be distributed in a timely manner in order not to adversely affect project progress and scheduling. There was general consensus among stakeholders that the CEC AB118/AB8 funding fills a needed gap in the commercialization spectrum for alternative fuels and vehicles.

CalRecycle loans and grant funding (RMDZ program) provides low interest loans for anaerobic digestion projects. Funding release has been slowed by legislative action. Stakeholders stated that the funding must be made available when expected so projects can be properly planned and funds used effectively.

RINS and LCFS credits can add revenue to projects to make them more economically attractive. Financial partners often do not include these credits when they evaluate projects for funding because the future of these credits is uncertain and the credit pricing fluctuates significantly. Stakeholders stated repeatedly that in order to help companies secure financial partner funding, RINS and LCFS credits should be fixed long term through the legislation. The availability and pricing should be fixed for periods of at least 10 years.

There are tax incentives for electricity but not for transportation fuels. Hence stakeholders stated that biofuel technology applications tend to move toward electricity rather than to transportation. Assuming the need to shift to more biofuels in transportation to help achieve environmental or other goals, there should be tax incentives for renewable transportation fuels.

The ARFVTP program does not allocate enough funding to biofuels, according to workshop participants even though biofuels produce the majority of program benefits and generate most of the LCFS credits. A biofuels funding initiative, which would include an in-state production

incentive and infrastructure expansion, was proposed at the workshop and was widely supported. Funds could be allocated based on CalEnviroScreen scoring.

State and federal funding is not well integrated with private capital according to stakeholders. Mechanisms could be, in the view of workshop participants, put in place to leverage public funding to create synergies between the two. Government funding agencies should work with private funders to identify opportunities, vet technologies, and oversee management to enhance the effectiveness of the funding.

### **Government Policies**

Stakeholders agreed that it is critical to have consistent, strong, reliable, and coordinated government policies to send the message to industry that they can rely on these policies when planning projects.

Compliance policies should be coordinated across all relevant agencies. For example, the Clean Air Act and the California Environmental Quality Act (CEQA) require agencies to identify the significant environmental impacts of projects and to ensure that negative impacts are avoided or mitigated.

Building codes, program rules, and reporting requirements are often changed frequently and can make compliance extremely difficult. One possible solution to coordinating and producing more consistent government policies is the creation of a high-level biofuels task force. The task force would interact with all relevant government agencies which oversee environmental policies and help to eliminate barriers between these agencies. Industry participation on the taskforce would be imperative.

Stakeholders stated that infrastructure must be developed to work well with the existing transportation fuels industry. Since most renewable transportation fuel is blended with fossil fuels (e.g. renewable diesel and RNG), to increase renewable fuel blending, stakeholders suggested that government should invest in storage and blending infrastructure. They also stated that government should work with the existing petroleum and natural gas industries to find solutions to the barriers to blending.

The EPA consistently sets renewable fuel requirements well below total capacity, according to stakeholders; the requirements should be set close to what the industry can actually produce. The California LCFS is performance based, but the Renewable Fuel Standard (RFS) is not. The RFS should be changed to be based on performance.

### *2.3.3 Ways to improve the business climate for biofuel commercialization by increasing private investment, oil industry involvement, and general economic profitability*

The following recommendations to improve the business climate for biofuels were suggested by invited speakers and discussants at the workshop:

- California state agencies could guarantee 90% of RNG project asset-secured debt (whether bonds or commercial debt) with a term of 15 years (including up to 2 years of construction and 13 year amortization) used to finance up to 80% of capital expenditures and related debt costs. A projected Debt Service Coverage Ratio of 1.2:1 would be required to qualify for state agency guarantee. The state credit rating could be made available to RNG projects without immediate, or perhaps any, use of tax dollars.
- Obligated parties under the LCFS must be willing to enter into a 15 year RNG Purchase Agreement with a formula for pricing RINS and LCFS credits (as opposed to fixed price) and with a “regulatory out” if the RFS2 program or the LCFS credits program terminates.
- Loan guarantees should support RNG projects that meet California objectives of reducing the number of diesel vehicles on road and the adoption of alternative fueled vehicles, such as CNG/LNG.
- Greater state support, including cap-and-trade auction revenue, is needed to benefit in-state California biofuel production.
- Offer of financial incentives for incumbent companies to encourage them to sell biofuels is needed.
- Improved access and financial support for in-state feedstock production is needed. (More recommendations are noted in Section 5.3.)

### *2.3.4 Ways to improve the carbon intensity and long-term availability of feedstocks for low carbon fuels*

It is important to have a rational, transparent approach to determining the carbon intensity of feedstock and biofuels that is applicable as technologies and policies change. This will improve both the reliability of carbon intensity estimates and the availability of feedstock.

One approach to determining the carbon intensity of biogas and biofuels is that termed ‘counterfactual’ - that is, what would be the result if no biofuel/biogas was produced vs. what would be the result if it were produced. This comparison should include consideration of alternate uses of the relevant feedstock when that is appropriate.

Taking the example of biomethane, applying the counterfactual approach is extremely favorable as it can even make the carbon intensity of biogas negative. If no biogas were collected, carbon would leak to the atmosphere from decaying biomass. By creating the biogas pathways, this carbon is collected and put to useful work as a fuel. The counterfactual approach varies across feedstocks. In the case of landfills and wastewater treatment plants (WWTP), most regulations require producers to flare the biogas, which is better in the short term for the

climate than just venting it. Flaring converts methane to carbon dioxide. Therefore, there is a tradeoff where less powerful but longer lived CO<sub>2</sub> is emitted instead of more powerful and short term methane. In the case of manure, where no flaring is possible, the gas would just be leaked into the atmosphere. The counterfactual approach here would be methane (not CO<sub>2</sub>) emitted to the atmosphere.

The counterfactual approach for forest and agricultural residue-sourced biogas is either rotting dead wood or agricultural residues left to decompose or be burned. These residues can be collected and processed using thermochemical processes (gasification) to produce biogas. If these residues are used to produce biofuels, the same counterfactual approaches apply. However it might be preferable to convert to biogas rather than to biofuel given that the process is simpler and the inefficiencies of each conversion step are avoided.

An aspect that can greatly increase any fuel carbon intensity is the ratio of energy-input to energy output (E<sub>i</sub>:E<sub>o</sub>). Lower ratios are better. The ratio is dependent on 1) the mechanization of the planting and harvest of the crop and how much chemical fertilizer is needed, 2) the biomass yield, and 3) the biofuel yield. Minimizing the first and maximizing the second and third will improve the E<sub>i</sub>:E<sub>o</sub> ratio. This is why sugarcane ethanol from Brazil has significantly lower carbon intensity than American corn ethanol. The former has low energy inputs (mostly human labor) and high sugar yields (thus high ethanol yields), and the latter is highly mechanized (high energy inputs) and has lower sugar content (lower ethanol yields). If cellulosic biofuels are commercial, they would be equivalent to using more of the biomass that grows naturally. Therefore, the ratio of E<sub>i</sub>:E<sub>o</sub> would also decrease. For this reason cellulosic biofuels will have lower carbon intensity than the first generation biofuels.

From this perspective, the amount of low carbon intensity biofuels available are probably limited. The very low (or even negative) carbon intensity biofuel/biomass only exists if produced from wastes. For the non-waste based biofuel, cellulosic feedstocks would be preferred to starchy/sugar based biofuels but cellulosic processes are not yet fully commercial. In summary, the lowest carbon intensity biogas/biofuels will be produced from wastes. For non-waste feedstocks, it is important to minimize land use change that result in a net release of carbon. Finally, for any feedstock/biofuel/biogas case, inefficiencies should be reduced in each conversion step, because conversion yields are the normalizing factor in the estimation of the carbon intensity.

### *2.3.5 Ways to accelerate the development of technology for biofuels, especially drop-in bio-gasoline and diesel, from cellulosic feedstocks*

The development of technology to produce drop-in, hydrocarbon biofuels has been slow, and at the present time there is no significant production of drop-in gasoline or aviation jet fuel. There is significant production of drop-in diesel fuel, but it is primarily produced from soybean and other oils, which are not ideal feedstocks for future, large scale, sustainable fuel production. In order to establish large scale production capability (many bgge/yr), it is

necessary to develop cost-effective technologies for producing hydrocarbon, biofuels and very large, sustainable sources (many million metric tons/yr) of cellulosic feedstock. Neither of these requirements are currently close to being met. Development of the production technology will require large R&D and capital investments over long periods of time (> 10 years). This will result only if there is a national commitment to replace fossil-based fuels for vehicles with biofuels that is evident from regulations and fuel and price incentives that will remain in place for at least 10 years. Hopefully, this commitment will encourage the large oil companies to get re-involved with biofuel production and marketing.

Providing the large scale, sustainable feedstock supply will require state and national, coordinated programs that will organize both the production and gathering of the cellulosic feedstocks needed. These feedstocks must be low carbon intensity to satisfy the LCFS and RFS requirements, which will become more demanding in future years. Financial incentives for both capital investments in technology R&D and to feedstock suppliers will be necessary over many years. This will be possible only if the U.S. makes a firm commitment to replace a significant fraction of its fossil-based fuels with sustainable, biofuels.

### *2.3.6 Ways to increase customer demand for biofuels to enhance investments in infrastructure and vehicles that can use biofuels*

There are two ways to have high demand for biofuels. One way is to require, through regulation, blends of biofuels with fossil-based fuels, as in the case of gasoline and ethanol. The demand for ethanol would increase significantly if the blend fraction was increased from 10% to 15%. The second way is to have the price of the biofuel to the consumer be lower than the competitive fossil-based fuel. This is the approach taken in Brazil to promote the use of sugarcane based ethanol. Vehicles sold in Brazil are required to have bi-fuel capability. The biofuel is kept competitive by varying the tax on the different fuels as the price of oil changes.

As of July 2015, in most states in the US the per-gallon cost of E85 was below the cost of gasoline (AFDC July 2015), and in some cases (e.g. California), it was substantially less. However, some consumers are aware that, on a per-gallon basis, the energy content of E-85 is not as high as gasoline and consequently, the fuel economy of their vehicle will be lower with E85. Experience has shown that most drivers of flex-fuel vehicles in the US use mostly gasoline, not E85.

Cost aside, consumers must be assured that the use of a biofuel will not damage the engine in their vehicle or negate the vehicle warranties. According to one workshop participant, some of the federal labeling of biofuels is more restrictive than warranted based on actual engine performance tests. Hence, the labeling should be re-evaluated so as to not to discourage consumers un-necessarily from using biofuels.

Stakeholders at the workshop noted that the California Air Resources Board has not encouraged the use of biofuels as strongly as it has other alternatives such as EVs and fuel cell



vehicles. Large incentives to buyers of EVs have increased demand for those vehicles. On the other hand, biofuels not only lack those incentives, but the national blend wall has also limited the fuels' penetration into the market. One participant at the workshop suggested that setting minimum quotas for a certain percentage of flex fuel vehicles sold by manufacturers could also stimulate demand. This would increase ethanol demand if the price of E85 on an energy basis was less than gasoline.

### 3. Findings of Session #1; setting the stage: Status (2015) of biofuels markets

#### 3.1 Quantities of fossil fuels used in 2014-15

For purposes of comparison, it is of interest to note the quantities of fossil-based fuels sold in the U.S. and California in 2014-15. These fuels include gasoline, diesel, and natural gas. The sales of the various fuels are shown in Table 1 below.

**Table 1. Fossil-based fuel sales in the U.S. and California (EIA statistics for 2014)**

Fossil-based fuel	Sales, U.S.	Sales, California
Gasoline	137 x10 <sup>9</sup> gge/yr	15 x10 <sup>9</sup> gge/yr
Diesel	36 x10 <sup>9</sup> gge/yr	3 x10 <sup>9</sup> gge/yr
aviation jet fuel	16 x10 <sup>9</sup> gge/yr	NA
Natural gas	35 bcf (280 x 10 <sup>3</sup> gge/yr)	17 bcf (136 x 10 <sup>3</sup> gge/yr)

The table indicates that billions of gallons of gasoline, diesel, and jet fuel are used in the U.S. and California. Hence in order for biofuels to have a significant effect on either the petroleum used for transportation fuels or GHG emissions from vehicles, it is necessary that billions of gallons of biofuels be produced from sustainable, low carbon intensity (gCO<sub>2</sub>/MJ) feedstock (see Table 2). Estimated production of biofuels in 2020 are not available for all cases of biofuel and feedstock.

**Table 2. Status of the production of various biofuels 2015-2020**

Fuel	Feedstock	California		U.S.		Reference sources
		2014 actual (bg/y)	2020 projected (bg/y)	2014 actual (bg/y)	2020 projected (bg/y)	
ethanol	Corn	1.6 used .22prod.		14.7 used	12 prod	California Biomass Consortium, CBMC; USEIA1
ethanol	cellulosic	0.22 prod. -----	.40 prod.			California Biomass Consortium
biodiesel	Cooking and crop oils	0.065	0.31	1.8	2.0	USEIA1; RusTeall,workshop
Renewable diesel	Oils and adv. proc.	Mostly imports	-----	Mostly imports	-----	USEIA2
Drop-in gasoline	cellulosic	-----	-----	.5	-----	USEIA3
Renewable natural gas	Wastes and landfills	0.26 bgge/y	0.76 bgge/y	2.3 bgge/y (available)	6.1 bgge/y (potential)	CBMC; USDA August 2014
Hydrogen from biogas	Wastes and landfills	-----	-----	1.6 bgge/y (available)	4.2 bgge/y (potential)	NREL July 2014

### 3.2 Biodiesel and renewable diesel

Both biodiesel and renewable diesel can be derived from biomass. However, biodiesel and renewable diesel are two distinctly different fuels and are produced via different technologies. Soybean oil remains the largest feedstock for producing biodiesel.

#### 3.2.1 Biodiesel

Biodiesel is defined as the mono alkyl esters of long-carbon-chain fatty acids derived from renewable lipid feedstocks. It is produced through a transesterification process, reacting fatty

acids contained in oil-rich biomass and animal fats catalytically with an alcohol (typically methanol or ethanol). The transesterification requires an alkaline catalyst, normally potassium hydroxide, and the dilute acid esterification needs the presence of sulfuric acid. Biodiesel is also referred to as FAME (fatty acid methyl ester) or RME (rape seed methyl ester) in Europe. Biodiesel is chemically different from petro-diesel and renewable diesel because it contains oxygen atoms. Biodiesel can be produced from a large variety of feedstocks:

- Virgin oil feedstock such as soybean oils and rapeseed are typical feedstocks;
- Waste vegetable oil;
- Animal fats;
- Algae is a new feedstock and currently under investigation;
- Oil from halophytes such as *Salicornia bigelovii*.

### **3.2.2 Renewable Diesel**

Renewable diesel, also called “green diesel” or “second generation diesel,” refers to fuels derived from biomass that are chemically not esters, and which are produced via different processing methods, such as hydrothermal processing, hydroprocessing (hydrotreating or hydrodeoxygenation), or indirect liquefaction. Renewable diesel has petrodiesel-like chemical composition.

#### **Hydrothermal Processing**

Hydrothermal processing is also called thermal depolymerization, cracking, and pyrolysis. In hydrothermal processing, biomass is reacted in water at elevated temperature and pressure (typically 570-660°F and 100-170 atm.) to form oils and residual solids. Reaction times are on the order of 15-30 minutes. The process converts the large polymers of biomass into smaller molecules. After reaction, the organics are separated from the water; a distillate cut suitable for diesel use is thus produced.

#### **Hydroprocessing**

The hydroprocessing process is currently utilized by petroleum refineries. In the hydroprocessing process, feedstock can be the same as for biodiesel or renewable diesel, and the feedstock is reacted with hydrogen in the presence of a catalyst under elevated temperature and pressure (typically 600-700°F and 40-100 atm.). The reaction times are on the order of 10 – 60 minutes. The triglyceride-containing oils can be hydroprocessed either as a co-feed with petroleum or as a dedicated feed using existing refineries. Many companies are utilizing this hydrotreating process as the basis for their renewable diesel projects.

#### **Indirect Liquefaction (Fischer-Tropsch Process) for Cellulosic Biodiesel**

In the indirect liquefaction process for making renewable diesel fuel, biomass (predominately cellulosic material) is converted, through high temperature gasification, into synga. The syngas is then catalytically converted into liquid fuel using Fischer-Tropsch process. There are different

gasification and pyrolysis processes available to produce the syngas [Canabarro]. This indirect liquefaction technology has been applied to coal-to-liquids fuel and natural gas-to-liquids fuel. Common feedstock for gasification includes:

- Agricultural crop residues;
- Forest residues;
- Energy crops;
- Organic municipal wastes and animal wastes.

### 3.2.3 Status of U.S. Biodiesel and Renewable Diesel

Both biodiesel and renewable diesel fuels are currently produced from refining vegetable oils such as soybean oil, canola oil, corn oil, palm oil, and others, or animal fats such as poultry and tallow (Table 3). Soybean oil remains the largest feedstock.

**Table 3. Yearly U.S. Inputs to Biodiesel Production (million pounds)\***

Feedstock	Vegetable Oils					Animal Fats	
Period	Soybean Oil	Canola Oil	Corn Oil	Palm Oil	Other	Poultry	Tallow
2013	5,507	646	1,068	632	---	160	465
2014	4,802	1,046	970	63	96	173	355

\*data from the Energy Information Administration

The total U.S. production of biodiesel was 1,270 million gallons with an average annual production capacity of 2,090 million gallons in 2014. The 212 million gallons of biodiesel imported into the U.S. in 2014 was sourced primarily from Canada (47%), reclaiming its spot as the top U.S. supplier after being surpassed by Argentina in 2013. The remaining volumes of regular biodiesel imports entered the U.S. primarily on the East Coast, mostly from Indonesia and Argentina. U.S. renewable diesel imports reached 121 million gallons in 2013, down 42% from 2013. Slightly more than 92% of total U.S. renewable diesel imports came from Singapore and entered the U.S. primarily through West Coast ports, likely destined for California LCFS compliance. The yearly and monthly U.S. biodiesel production, consumption, imports, exports, and feedstock are shown in the following figures.

### Biodiesel and Other Renewable Fuels Overview

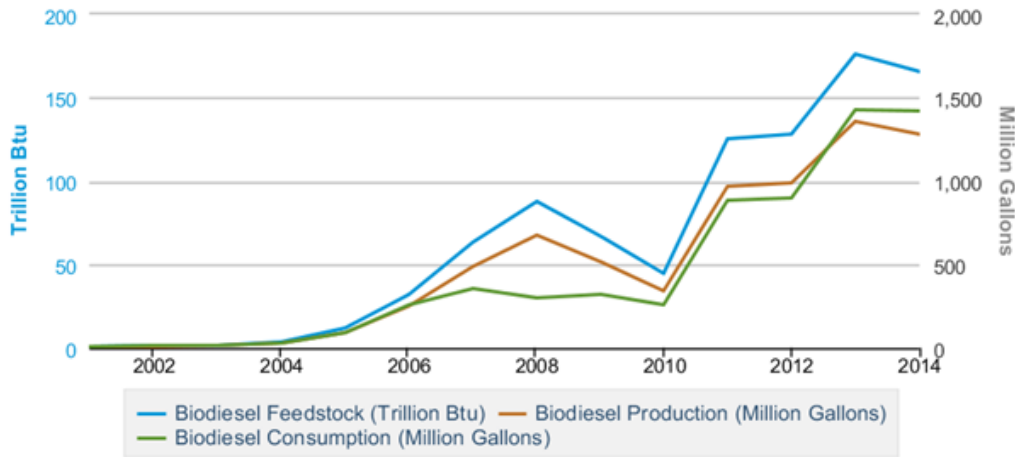

Data source: U.S. Energy Information Administration

Figure 1. Yearly U.S. Biodiesel Feedstock<sup>1</sup>, Biodiesel Production, and Biodiesel Consumption

### Biodiesel and Other Renewable Fuels Overview

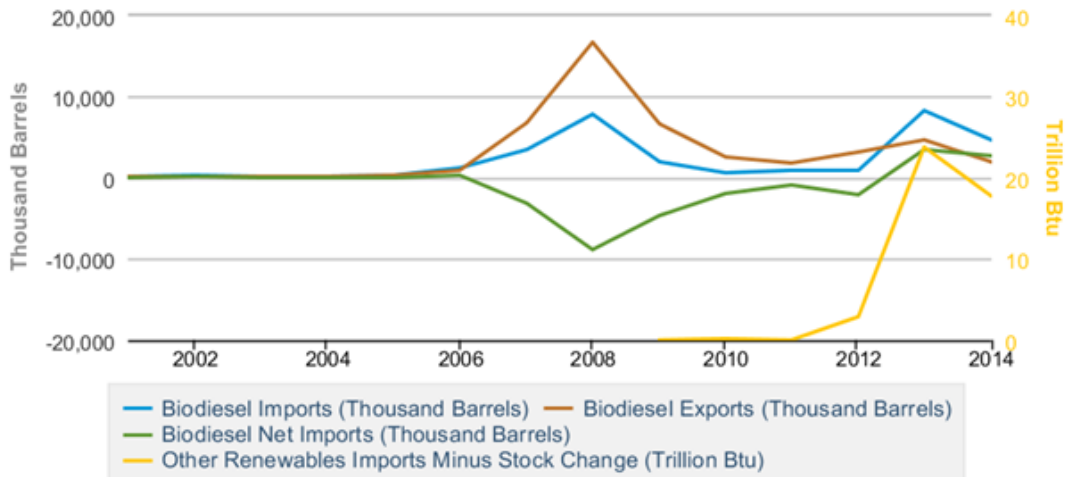

Data source: U.S. Energy Information Administration

Figure 2. Yearly U.S. Biodiesel Imports, Exports, Net Imports, and Other Renewable Fuel<sup>2</sup> Imports

<sup>1</sup> Feedstock: total vegetable oil and other biomass inputs to the production of biodiesel – calculated by multiplying biodiesel production by 5.433 million Btu per barrel.

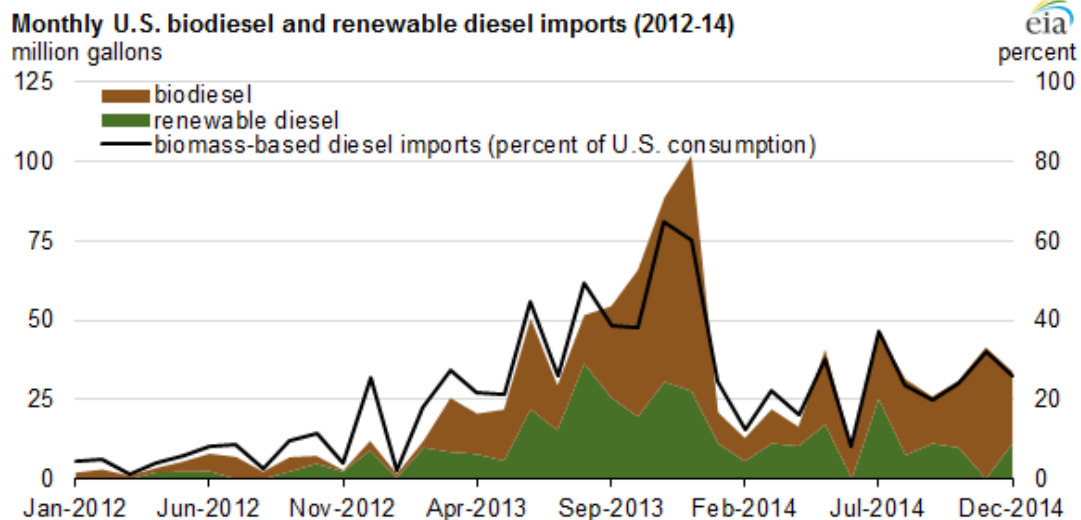
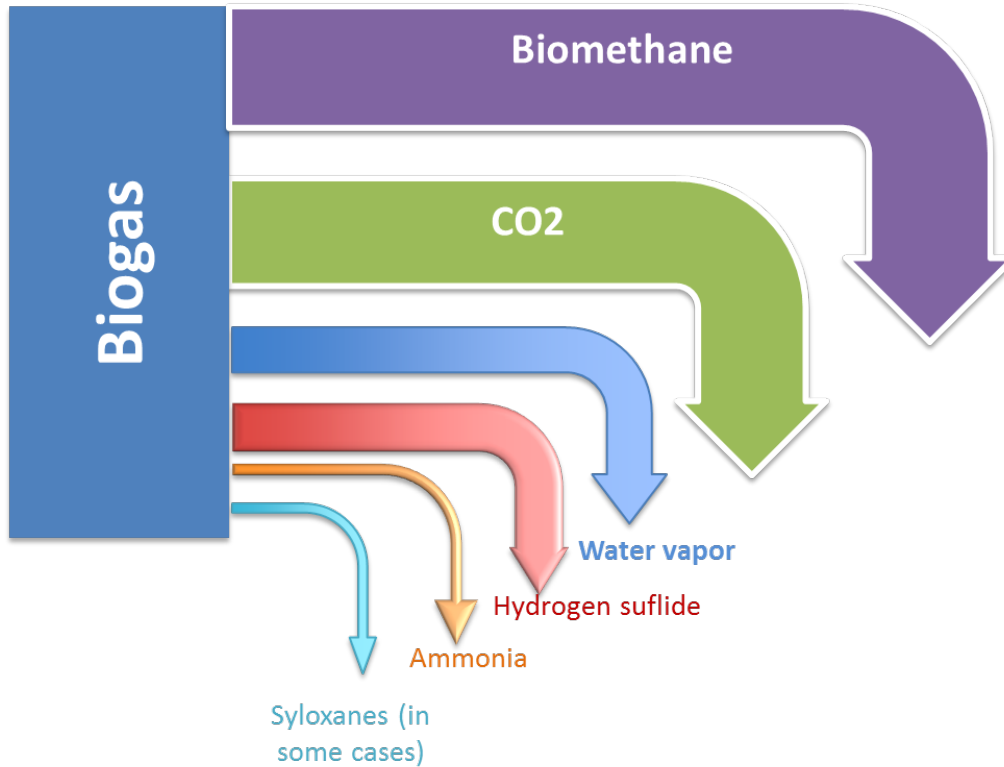

**Figure 3. Monthly U.S. Biodiesel and Renewable Diesel Imports**

### 3.3 Biomethane

Organic waste that is anaerobically digested produces biogas. Biogas is comprised of biomethane, bio-CO<sub>2</sub> and other trace elements with compositions that vary depending on the feedstock of origin. Biomethane is the component of interest, as it is chemically identical to methane in fossil natural gas. Unlike fossil methane, however, it is produced from renewable sources; thus it is also called RNG. Any kind of biomass can theoretically be fermented anaerobically into biogas, but common biomethane feedstocks include organic waste in urban solid waste (i.e., food or green waste), manure, and wastewater treatment plant sludge. Organic matter landfilled decays anaerobically and generates landfill biomethane (i.e., landfill gas). The biological process is the same as in anaerobic digesters, only that it is uncontrolled, with the sole intervention being that of collecting and managing the biogas via venting, flaring or combustion. Biomethane can also be formed thermochemically via gasification of organic materials into synthetic gas (i.e., syngas) followed by methane engineering synthesis. The thermochemical pathway is more appropriate for cellulosic feedstocks that are not easily digested by microbes or for waste streams with inconsistent composition, the latter unsuitable for the biological process. On the other hand, biological conversion of biomass to methane, when possible, is less costly.

<sup>2</sup> Other renewables include other renewable diesel fuel and other renewable fuels, produced from renewable biomass



**Figure 4. Separation steps necessary for the upgrading of biogas to biomethane**

Untreated biogas (Table 4) can be used for combined heat and power applications under the right conditions. According to an American Biogas Council 2005 report, dairy manure biogas can be used on-farm for direct electrical generation without special biogas treatment when the proper engine/boiler and maintenance protocols occurred (Krich et al., 2005).

Similarly, untreated biogas can theoretically be used as a transportation fuel in spark ignited gasoline engines that have been converted to operate on biogas with proper maintenance. However, vehicular gas specifications exist to ensure compatibility with engines designed to operate on natural gas.

**Table 4. Untreated biogas differs considerably from that of fossil natural gas (Krich et al., 2005)**

Component	CNG Fuel Specification <sup>a</sup>	Raw Biogas Composition <sup>a</sup>
Methane (CH <sub>4</sub> )	≥ 88	65
Ethane (C <sub>2</sub> H <sub>6</sub> )	≤ 6	≤ 0.1
C <sub>3</sub> + (Propane, etc.)	≤ 3	≤ 0.1
C <sub>6</sub> + (Hexane, etc.)	≤ 0.2	≤ 0.1
Hydrogen (H <sub>2</sub> )	≤ 0.1	≤ 0.1
Carbon monoxide (CO)	≤ 0.1	≤ 0.1
Oxygen (O <sub>2</sub> )	≤ 1.0	≤ 0.1
Inert gases (CO <sub>2</sub> + N <sub>2</sub> )	1.5 – 4.5 (range)	35
Sulfur	16 ppm	50 – 2000 ppm
Dew point	≥ 10° F below 99% winter design temp <sup>b</sup>	Saturated (non-compliant)
Particulate matter	Non-damaging to engines, etc.	Variable
Odorant	Easily detectable	Detectable

<sup>a</sup> Expressed as % unless otherwise noted.

<sup>b</sup> ASHRAE, 1989 (Chapter 24, Table 1).

Biogas's exact composition varies according to feedstock of origin (Table 5). American landfill gas and wastewater-sourced biogas, unlike other types of biogas, contain siloxanes. This is not the case in Europe, as the chemical that promotes siloxane formation is banned from hygienic and cosmetic products.



Table 5. Composition of EU landfill and AD biogas compared to fossil natural gas (Mintz, Han, Wang, & Saricks, 2010)

**TABLE 2 Composition and Characteristics of Biomethane and Fossil Natural Gas**

Parameter	Unit	EU AD-Based		NG from NA	NG from NNA	NG distributed in
		EU LFG	Biogas	Gas Field	Gas Field	US
Source		(Persson et al. 2006)		(Segeler 1965)		
LHV: average range	Btu/ft <sup>3</sup>	406	584	1081 835-1336	1145 627-1717	1049 945-1121
Density: average range	g/ft <sup>3</sup>	34.8	32.1	22.4 19.5-27.9	23.9 19.5-36.9	21.5 20.3-24.6
CH <sub>4</sub> : average range	vol %	45 36-65	63 53-70	51.5 84.7-98.8	77.0 22.8-98.0	89.4 72.8-95.2
H <sub>2</sub> : average	vol %	0-3	0	-	-	-
CO <sub>2</sub> : average range	vol %	40 15-50	47 30-47	0.55 0-6.0	4.1 0-29.0	0.7 0-2.0
N <sub>2</sub> : average range	vol %	15 5-40	0.2 -	4.03 0-29.4	1.7 0-12.1	2.9 0-17.1
O <sub>2</sub> : average range	vol %	1 0-5	0 -	0.06 0-0.4	0.1 0-1.4	0.0 0-0.4
H <sub>2</sub> S: average range	ppmv	<100 0-100	<1000 0-10000	100 0-3100	400 0-5200	
NMOC: average (as Hexane) range	ppmv			1100 0-6600	2000 0-17000	400 0-1400
NH <sub>3</sub>	ppm	5	<100	-	-	-

**Table 6. (European) composition of biogas by feedstock types<sup>3</sup>  
(NaskeoEnvironnement, 2009)**

Components	Household waste	Wastewater treatment plants sludge	Agricultural wastes	Waste of agrifood industry
CH4 % vol	50-60	60-75	60-75	68
CO2 % vol	38-34	33-19	33-19	26
N2 % vol	5-0	1-0	1-0	-
O2 % vol	1-0	< 0,5	< 0,5	-
H2O % vol	6 (à 40 ° C)	6 (à 40 ° C)	6 (à 40 ° C)	6 (à 40 ° C)
Total % vol	100	100	100	100
H2S mg/m3	100 - 900	1000 - 4000	3000 - 10 000	400
NH3 mg/m3	-	-	50 - 100	-
Aromatic mg/m3	0 - 200	-	-	-
Organochlorinated or organofluorated mg/m3	100-800	-	-	-

There exist a range of mechanisms to separate biomethane from bio-CO2 and other components. The different processes have different costs. In addition to being cleaned, biomethane must be purified. Biomethane purity (energy density) requirements change if the biomethane is to be used in-situ or injected into the pipeline. The more stringent pipeline biomethane purity requirement from California utilities, 990+ Btu/scf (vs. 950 in other states) penalizes in-state biogas consumption since other states with less stringent pipelines inject their biomethane out of state and transport it via transmission lines for in-state consumption.

<sup>3</sup> Europe does not find siloxanes in landfill and WWTP because they ban certain chemical in hygienic products that converts into siloxanes.

**Table 7. California pipeline injection requirements (USDA 2005 Biomethane Source Book)**

Table 7-3 Basic Pipeline Quality Standards for Major California Distributors

Gas Component or Characteristic	Pacific Gas and Electric Company	Southern California Gas Company
Carbon dioxide (CO <sub>2</sub> )	≤1%	≤3%
Oxygen (O <sub>2</sub> )	≤0.1%	≤0.2%
Hydrogen sulfide (H <sub>2</sub> S)	≤0.25 grains/100 scf	≤0.25 grains/100 scf
Mercaptan sulfur	≤0.5 grains/100 scf	≤0.3 grains/100 scf
Total sulfur	≤1 grain/100 scf	≤0.75 grains/100 scf
Water (H <sub>2</sub> O)	≤7 lb/million scf	≤7 lb/million scf
Total inerts	No requirement	≤4%
Heating value	Specific to receipt point	990 – 1,150 Btu/scf
Landfill gas	Not allowed	No requirement
Temperature	60 – 100° F	50 – 105° F
<i>Gas Interchangeability</i> <sup>a</sup>		
Wobbe number	Specific to receipt point	Specific to receipt point
Lifting index	Specific to receipt point	Specific to receipt point
Flashback index	Specific to receipt point	Specific to receipt point
Yellow tip index	Specific to receipt point	Specific to receipt point

scf = Standard cubic feet

Btu = British thermal units

<sup>a</sup> The various indices— Wobbe number, Lifting index, Flashback index, and Yellow tip index—are all means of determining the gas interchangeability (AGA, 1946)

Biomethane that does not meet pipeline quality specifications is often called “treated biogas” by the industry. This biogas must be free of siloxanes<sup>4</sup> and hydrogen sulfide, but tolerates the presence of carbon dioxide and other inerts that lower the energy content, as shown in the tables below from Sempra Energy (Tables 7 and 8). An update of the specifications for “treated biogas” can be found on page 21 of Tariff Rule 30.

<sup>4</sup> There are various species of siloxanes, which are volatile compounds cyclic in structure. Siloxanes take the form of a white powder, primarily silicon dioxide (SO<sub>2</sub>), and are typically found in the hot section of gas turbine components, heat exchangers, on combustion surfaces in reciprocating engines, and on post-combustion catalysts. Silicon dioxide (SO<sub>2</sub>) is a product of siloxane combustion. Siloxanes can induce microturbine and catalyst failures. Siloxanes are found in biogas from landfill and waste water treatment plants. *Siloxanes in Landfill and Digester Gas Update Ed Wheelless Los Angeles County Sanitation Districts Whittier, California Jeffrey Pierce SCS Energy Long Beach, California*

Table 8. Social Gas definition of biogas, treated biogas and biomethane. Hydrogen sulfide and water make biogas corrosive.

## Biomethane Market: Differences Between Biogas & Biomethane

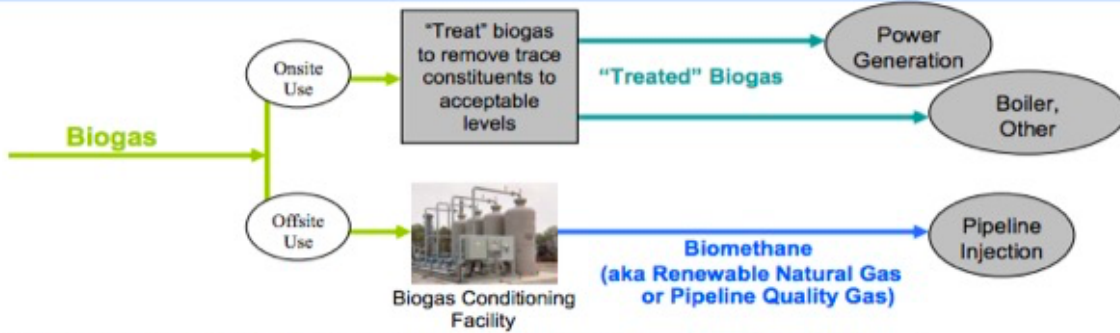

Illustration for Landfill Diverted Waste	Biogas	"Treated" Biogas	Biomethane*
<b>Gas Composition and Heating Value</b>			
CH4	62.0%	62.0%	98.5%
CO2	37.6%	37.6%	0.8%
O2, H2, N2, Others	0.4%	0.4%	0.7%
Heating Value (btu/scf)	625	625	990+
<b>Two of the Key Trace Constituents</b>			
H2S	300 ppm	1 ppm	1 ppm
Siloxanes	4,000 ppb	70 ppb	Non-detectable

\* Gas composition and trace constituent limits will/may differ by utility



### Biogas Resource Potential

Estimates of biogas potential have been estimated by several different groups: NPC, NREL and UC Davis. A 2012 analysis by the National Petroleum Council (NPC, 2012) found 4.7 TCF (trillion cubic feet, or 32.65 billion diesel gallon equivalent) were available nationally, but this included all the energy crops, agricultural and forestry wastes that could be gasified. The NPC report included all biomass sources, including those that are more likely to be converted to biofuel or electricity (see Figure 5).

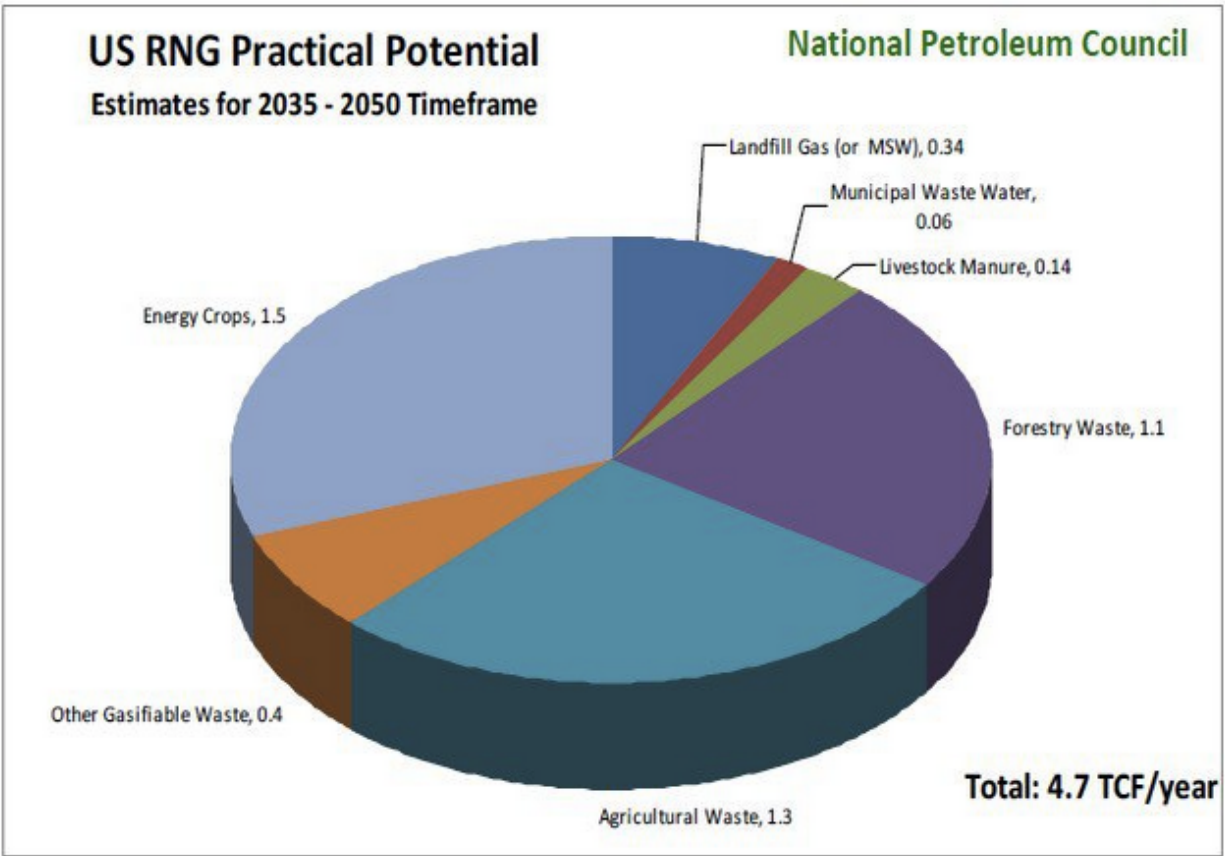

**Figure 5. NPC estimate of biomethane potential from biochemical and thermochemical pathway**

A 2014 NREL report (NREL, 2014) (Table 9) looking at methane that could be converted biochemically from the landfills, animal manure, wastewater, and organic waste in the US is about 8 million tons per year, equivalent to 420 billion cubic feet (equivalent to 5% of natural gas consumption for electric power or 56% of current transportation natural gas consumption). Total natural gas consumption in the US was a little over 26 TCF in 2013, so RNG has the potential to provide up to provide 18% of the total in the long term (2030). The NPC estimated costs for RNG at a range from \$5-\$11 per million Btu for common digester projects and up to a high of \$25 per MMBtu for gasification projects with expensive feedstocks. Current natural gas prices are around \$4 per MMBtu, but are volatile.

In a UC Davis study, estimates were made of the technical production of biogas from urban, agricultural and forestry based residues, waste water treatment facilities and landfills. Conversion of lignocellulosic materials was assumed via a thermochemical pathway (gasification-to-syngas followed by reforming to methane) to produce a synthetic renewable natural gas. The results are shown in the table below.

**Table 9. NREL estimates of methane generation potential for select biogas sources in the U.S.**

Estimated Methane Generation Potential for Select Biogas Sources in the United States

Source	Methane Potential (tonnes/yr)
Wastewater	2,339,339
Landfills*	2,454,974
Animal manure	1,905,253
IIC organic waste	1,157,883
<b>Total</b>	<b>7,857,449</b>

\* Includes candidate landfills only as defined by the EPA's Landfill Methane Outreach Program

**Table 10. California available feedstock and conversion to biomethane<sup>5</sup>**

Feedstock	Amount Technically Available	Biomethane Potential (billion cubic feet)	Biofuel Potential (million gge*) <sup>i</sup>
Agricultural Residue (Lignocellulosic)	5.3 MM BDT <sup>a</sup>	51.8 <sup>h</sup>	446
Animal Manure (Dairy & Poultry)	3.4 MM BDT <sup>a</sup>	19.5 <sup>a</sup>	168
Fats, Oils and Greases	207,000 tons <sup>b</sup>	1.9 <sup>j</sup>	16
Forestry and Forest Product Residue	14.2 MM BDT <sup>a</sup>	139 <sup>h</sup>	1200
Landfill Gas	106 BCF <sup>a</sup>	53 <sup>f</sup>	457
Municipal Solid Waste (food, leaves, grass fraction)	1.2 MM BDT <sup>c</sup>	12.7 <sup>g</sup>	109
Municipal Solid Waste (lignocellulosic fraction)	6.7 MM BDT <sup>c,d</sup>	65.9 <sup>h</sup>	568
Waste Water Treatment Plants	11.8 BCF (gas) <sup>e</sup>	7.7 <sup>k</sup>	66
<b>Total</b>		<b>351</b>	<b>3,030</b>

<sup>5</sup> Williams, R. B., B. M. Jenkins and S. Kaffka (California Biomass Collaborative). 2015. *An Assessment of Biomass Resources in California, 2013*. Contractor Report to the California Energy Commission. PIER Contract 500-11-020.

To compare the UC Davis estimates with those obtained by other groups, it is necessary to clarify the difference between *gross*, *technical* and *commercial* potential. Gross is a theoretical estimate of all possible production, whereas technical accounts for whether it is possible to capture it or not. For example, the gross potential for landfills includes all methane.

Figure 6 shows the difference between gross (yellow) and technical (brown) potential in California as estimated by UC Davis. It also shows the current natural gas consumed in transportation in California (15 BCF in 2014) and the 2022 projection from the EIA’s Annual Energy Outlook (2014 or 2013), which is slightly above that amount.

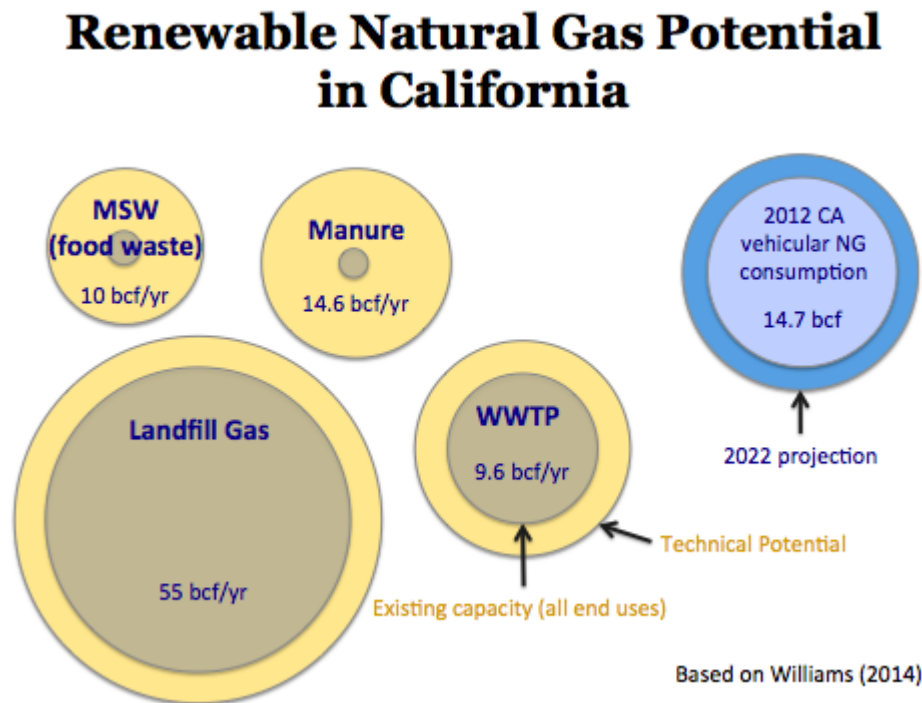

**Figure 6. Gross (yellow) and technical (brown) potential for biomethane in California by source. In blue is the current and projected (2022)<sup>6</sup> use of natural gas in transportation in California.**

UC Davis has estimated the technical potential for commercialization, that is, whether it could be produced competitively at current natural gas prices (~\$3/mmBtu), with and without subsidies. UCD has prepared a combined (i.e. all feedstocks under consideration) supply curve for RNG in California<sup>7</sup> that includes supply chain costs all the way to the delivery of biomethane in LNG or CNG stations. This supply curve indicates that the vast majority of biomethane is available only at \$5/mmBtu or more, and thus is not commercially competitive with current

<sup>6</sup> EIA Annual Energy Outlook 2013 or 2014

<sup>7</sup> UCD Biogas analysis.

natural gas prices without any type of subsidies. At current natural gas prices, only 0.5 bcf/year of biomethane are available, which represents about 3% of current natural gas use in transportation in the state. What makes RNG expensive is the capital costs of anaerobic digesters when needed (in the case of manure and organic urban waste), the cost of the clean up to pipeline quality standards, and interconnection construction costs. The cost of building a network of refueling stations for gaseous fuels is also incurred. Statewide subsidies would be needed at many levels in the supply chain. For example, a statewide subsidy to overcome the high capital investment of digesters could aide in the development of RNG, but that still leaves the cost of cleanup and interconnections to the pipeline. This cost is avoided by using the natural gas on site rather than having to inject it into the pipeline; however, then the cost of NGV equipment might be high. Even if barriers to injecting into the pipeline were overcome, the scarce gaseous fuel refueling infrastructure would pose a constraint. These barriers will be discussed in more detail in a later section, but for now it is worth noting that only 5% of the technical potential biomethane is commercially competitive with natural gas without any subsidies. This represents 30% of the total natural gas use in transportation in the state but only 0.1% of total diesel used in the state (Table 1 and 11). Subsidies can make biomethane competitive with natural gas, but cost is not the only barrier biomethane faces. Fossil natural gas prices are at historic lows and yet this fuel represents only a small fraction as compared to diesel fuel consumed suggesting other barriers, like cost of natural gas vehicles, cost of building a refueling network, and consumer behavior obstacles that have not been extensively studied in the trucking sector.

**Table 11. Biogas availability compared to other fuels for transportation**

	Biogas availability (annual) Natural gas and Diesel Consumption (annual)	Biogas as a percentage
Biogas	0.5 bcf/year (availability) (*983Btu/ft <sup>3</sup> implies 491Billion Btu/year)	
Natural gas vehicular use <sup>8</sup>	1.7 bcf/year (*983 Btu/ft <sup>3</sup> implies 1.7 trillion Btu/y)	30%
Diesel on road use <sup>9</sup>	2.7 billion gallons/year (*128,450 Btu/gallon implies 347 trillion Btu/y)	0.1%

<sup>8</sup> California natural gas vehicular fuel use in 2014 is 16.7 billion cubic feet  
[http://www.eia.gov/dnav/ng/ng\\_cons\\_sum\\_dcu\\_SCA\\_a.htm](http://www.eia.gov/dnav/ng/ng_cons_sum_dcu_SCA_a.htm)

<sup>9</sup>California On road Distillate consumption in 2013 is 2.7 billion gallons  
[http://www.eia.gov/dnav/pet/pet\\_cons\\_821dst\\_dcu\\_nus\\_a.htm](http://www.eia.gov/dnav/pet/pet_cons_821dst_dcu_nus_a.htm)



## Current status of landfill gas

In 2012 there were 600 landfills in the US that convert LFG to energy either for power generation or in boilers. In contrast, only 41 landfills produce LFG-based vehicle grade RNG, either for injection into the pipeline system or on site vehicular use (US EPA 2013).

**Table 12. Landfills currently producing pipeline quality gas or vehicle fuel (EPA 2015)<sup>10</sup>**

Landfill Name	State	County	Landfill Owner Organization (s)	Waste in Place (tons)	Waste in Place Year	LFG Collected (mmscfd)	Project Start Date	LFG Flow to Project (mmscfd)	Project Developer(s)
Altamont Landfill & Resource Recovery Facility	CA	Alameda	Waste Management, Inc.	57,857,143	2009	8.33	9/1/2009	3.6	High Mountain Fuels
Billings City Landfill	MT	Yellowstone	City of Billings, MT	5,000,000	2009	0.895	12/7/2010	0.895	LFG Technologies, Inc.; Montana-Dakota Utilities Co.
Carter Valley Landfill	TN	Hawkins	Republic Services, Inc.	12,723,765	2005	1.58	4/1/2009	1.44	TenGasCo
Cedar Hills Regional LF	WA	King	King County Solid Waste Division, WA	33,000,000	2010	18.7	10/1/2010	10.6	Bio Energy Washington, LLC (BEW)
Dane County LF #2-Rodefeld	WI	Dane	Dane County Public Works, WI	4,029,904	2008	2.3	3/18/2011	0.03	Dane County Public Works, WI

<sup>10</sup> LMOP database of operational LFG energy projects, current as of March 2015.

<http://www3.epa.gov/lmop/projects-candidates/operational.html>

Landfill Name	State	County	Landfill Owner Organization (s)	Waste in Place (tons)	Waste in Place Year	LFG Collected (mmscfd)	Project Start Date	LFG Flow to Project (mmscfd)	Project Developer(s)
Fort Bend Regional Landfill	TX	Fort Bend	WCA Waste Corporation	7,000,000	2013	2.45	6/2/2013	2.45	Enerdyne Power Systems, Inc.; Morrow Renewables, LLC
Fort Smith SLF	AR	Sebastian	City of Fort Smith Department of Sanitation, AR	8,552,007	2013	3.312	5/11/2006	2.16	Cambrian Energy Development LLC; Morrow Renewables, LLC
Franklin County SLF	OH	Franklin	Solid Waste Authority of Central Ohio, OH	16,700,762	2011	7.344	7/31/2014		Aria Energy
Fresh Kills SLF	NY	Richmond	New York City Bureau of Waste Disposal, NY	108,361,626	1999	6.53	1/1/2010	6.97	Montauk Energy Capital
Greentree Landfill	PA	Elk	Advanced Disposal Services	17,407,097	2009	10.08	7/1/2007	3.6	American Exploration; enXco LFG Holdings, LLC
Greenwood Farms Landfill	TX	Smith	City of Tyler, TX	5,500,000	2008	2.304	4/22/2009	2.304	Morrow Renewables, LLC
IESI Turkey Creek Landfill	TX	Johnson	Progressive Waste Solutions Ltd.	11,022,493	2013	1.92	9/30/2012	1.87	Morrow Renewables, LLC
Imperial Sanitary Landfill	PA	Allegheny	Republic Services, Inc.	12,890,151	2010	10.3	9/1/2007	4.2	enXco LFG Holdings, LLC
Jefferson Davis Parish Landfill	LA	Jefferson Davis	Jefferson Davis Parish Sanitary Landfill Commission, LA	9,584,310	2013	2.14	4/1/2008	2.14	Morrow Renewables, LLC

Landfill Name	State	County	Landfill Owner Organization (s)	Waste in Place (tons)	Waste in Place Year	LFG Collected (mmscfd)	Project Start Date	LFG Flow to Project (mmscfd)	Project Developer(s)
Johnson County LF	KS	Johnson	Deffenbaugh Industries, Inc.	30,000,000	2008	7	9/1/2001	4.9	Energy Investors Funds Group; Enpower Corp.
Laurel Highlands LF	PA	Cambria	Waste Management, Inc.	5,870,124	2010	2.93	7/1/2006	2.93	Air Liquide-MEDAL; Leaf Clean Energy
Live Oak LF	GA	DeKalb	Waste Management, Inc.	5,266,000	2002	6.48	3/1/2009	6.48	Jacoby Energy Development, Inc.
McCarty Road LF	TX	Harris	Republic Services, Inc.	28,918,718	1998		3/1/1986	9.7	Montauk Energy Capital
McCommas Bluff Landfill	TX	Dallas	City of Dallas, TX	40,000,000	2013		1/1/2008	7	Cambrian Energy Development LLC; Clean Energy Renewable Fuels
Meadow Branch Landfill	TN	McMinn	Waste Connections, Inc.				9/28/2011	2.5	Renewco LLC
Milam Recycling and Disposal Facility	IL	St. Clair	Waste Management, Inc.	16,000,000	2004	5.05	12/31/2014	3.5	WM Illinois Renewable Energy, LLC
Monroeville LF	PA	Allegheny	Waste Management, Inc.	7,808,222	2010	3.87	10/29/2004	2.48	Montauk Energy Capital
North Sanitary Landfill	OH	Montgomery	Waste Management, Inc.	6,150,000		0.77	5/1/2003	2.672	DTE Biomass Energy
North Shelby Landfill	TN	Shelby	Republic Services, Inc.	5,500,000	2001	2.79	9/30/2014		Clean Energy Renewable Fuels

Landfill Name	State	County	Landfill Owner Organization (s)	Waste in Place (tons)	Waste in Place Year	LFG Collected (mmscfd)	Project Start Date	LFG Flow to Project (mmscfd)	Project Developer(s)
Oklahoma City Landfill	OK	Oklahoma	Waste Connections Inc. - Central Region	10,401,150			5/1/2008	2.02	Timberline Energy, LLC
Richfield Landfill	MI	Genesee	Richfield Landfill, Inc.			0.9	11/1/2006	0.9	Blue Skies Energy, LLC
River Birch Landfill	LA	Jefferson	River Birch, Inc.	7,500,000	2007	5.76	6/1/2010	5.76	River Birch, Inc.
Riverview Land Preserve	MI	Wayne	City of Riverview, MI	21,523,745	2008	6.12	4/1/2013	0.14	City of Riverview, MI
Rumpke SLF, Inc.	OH	Hamilton	Rumpke	36,267,372	2005	15	1/1/1986	6	GSF Energy; Montauk Energy Capital
Sauk Trail Hills Landfill	MI	Wayne	Republic Services, Inc.	3,000,000	1999	4.6	8/20/2013	4.6	Clean Energy Renewable Fuels
Seminole Road MSW Landfill	GA	DeKalb	DeKalb County Sanitation, GA	11,538,656	2013	3.168	2/26/2013	0.198	DeKalb County Sanitation, GA
Seneca Landfill Inc.	PA	Butler	Vogel Disposal Service, Inc.	5,337,252	2011	2.87	2/1/2011	2.68	Keystone Renewable Energy, LLC
Seneca Meadows SWMF	NY	Seneca	Progressive Waste Solutions Ltd.	24,289,318	2008	12.3	3/3/2014	4.32	Aria Energy; Innovative Energy Systems, LLC
Shade Landfill	PA	Somerset	Waste Management, Inc.	7,954,742	2010	2.38	9/1/2007	3.532	Keystone Renewable Energy, LLC; Leaf Clean Energy
Sonoma County Central Disposal Site	CA	Sonoma	Sonoma County, CA	15,000,000	2002		9/30/2009	1.24	SCS Engineers
South Hills Landfill	PA	Allegheny	Waste Management, Inc.	3,507,270	2010	1.18	7/1/2008	1.18	ARC Technologies Corporation

Landfill Name	State	County	Landfill Owner Organization (s)	Waste in Place (tons)	Waste in Place Year	LFG Collected (mmscfd)	Project Start Date	LFG Flow to Project (mmscfd)	Project Developer(s)
Southern Alleghenies LF	PA	Somerset	Waste Management, Inc.	5,885,033	2010	2.88	9/1/2007	3.532	Keystone Renewable Energy, LLC; Leaf Clean Energy
St. Landry Parish LF	LA	St. Landry	St. Landry Parish Solid Waste Disposal District, LA	2,750,000	2012	0.358	4/13/2012	0.07	St. Landry Parish Solid Waste Disposal District, LA
Stony Hollow Landfill Inc.	OH	Montgomery	Waste Management, Inc.	7,640,845	2005	2.69	5/1/2003	2.672	DTE Biomass Energy
Turnkey Recycling & Environmental Enterprises	NH	Strafford	Waste Management, Inc.	8,750,000	1999	16.56	7/1/2009	7.92	University of New Hampshire
Valley LF	PA	Westmoreland	Waste Management, Inc.	5,921,742	2010	2.67	2/27/2004	1.37	Montauk Energy Capital
Westside Recycling and Disposal Facility	MI	St. Joseph	Waste Management, Inc.	3,000,000	2001	2.5	1/1/1999	2.5	DTE Biomass Energy

The US EPA Livestock Anaerobic Digester Database lists 247 operational manure digesters and 13 more in construction in the US as of May 2015 (EPA 2015). The California Biomass Collaborative lists 142 wastewater treatment digesters operating in California (CBC 2015).

**Table 13. AD projects producing pipeline quality gas or vehicle fuel by size, location and operating status (EPA 2009)<sup>11</sup>**

**Table 4. AD Projects Producing Pipeline Quality Gas or Vehicle Fuel by Size, Location and Operating Status (EPA 2009b)**

Farm/Project Name	County	State	Status	Year Operational	Animal Type	Population Feeding Digester
Hilarides Dairy	Tulare	CA	Operational	2006	Dairy	1,500
Vintage Dairy	Fresno	CA	Operational	2008	Dairy	5,000
Scenic View Dairy - Fennville	Allegan	MI	Operational	2006	Dairy	3,650
Huckabay Ridge / Microgy	Erath	TX	Operational	2008	Dairy	10,000
Emerald Dairy	St. Croix	WI	Operational	2006	Dairy	1,600
Bison Renewable Energy - Cornerstone AD	Sioux	IA	Construction	2008	Swine & Cattle	
Westpoint Dairy	Gooding	ID	Construction	2007	Dairy	
Crossen Project - Microgy	Deaf Smith	TX	Construction	2009	Dairy	10,000
Rio Leche Project - Microgy	Erath	TX	Construction	2009	Dairy	10,000
Bar 20 Dairy 2 - Microgy	Fresno	CA	Planned		Dairy	19,100
Fort St. Vrain - Microgy	Weld	CO	Planned		Dairy	N.A.
Daley Farms LLP	Olmsted	MN	Planned		Dairy	950
Mission Project - Microgy	Deaf Smith	TX	Planned		Dairy	10,000
Whitesides Dairy	Minidoka	ID	Shutdown	2004	Dairy	2,900

As of 2012, only a handful of sites were using RNG as transportation fuel in the US.

<sup>11</sup> M. Mintz, J. Han, M. Wang, and C. Saricks Well-to-Wheels Analysis of Landfill Gas-Based Pathways and Their Addition to the GREET Model 2010

**Table 14. Sites using biomethane as a transportation fuel in the U.S. (CALSTART, 2012)<sup>12</sup>**

Waste Site	Location	Vehicles Fueled with RNG
Altamont Landfill	CA	300-400 refuse trucks
Fair Oaks Dairy	IN	42 milk delivery trucks
Rodefild Landfill	WI	25-30 vehicles
Sauk Trail Hills Landfill	MI	RNG leaves site via pipeline
Columbus bio-Energy Digester	OH	25+ vehicles
Janesville Wastewater Plant	WI	40+ vehicles by 2022
St. Landry Parish Landfill	LA	15+ vehicles
Rumpke Landfill	OH	10-15 refuse trucks
Blue Line Biogenic CNG Facility (Recycling Today 2015)	CA	Up to 18 collection vehicles
Sacramento South Area Transfer Station (CEC 2016)	CA	~ 2000 DGE/day
Hilarides Dairy (Dairy Cares 2016)	CA	2 milk trucks, 6 pickups
North State Rendering (CEC 2015)	CA	14 trucks
CR&R Digester (BioCycle 2015)	CA	Eventually ~ 4,000,000 DGE/yr

### 3.4 Drop-in hydrocarbon fuels

This category of biofuels refers to fuels that can be used in engines that are presently used in vehicles without modification of the engines. Hence the fuels can be a direct replacement or substitute for the fossil-based fuels currently being used. These biofuels are thus referred to as “drop-in” fuels. The drop-in fuels have the same physical and chemical characteristics as the fossil-based gasoline, diesel, and aviation jet fuels that they replace. It is further assumed that the emissions from the engines using the drop-in fuels will be essentially the same as those using the fossil-based fuels. Of the biofuels currently used, only renewable diesel is a drop-in fuel that can be used directly or blended with fossil-based diesel fuel in any ratio. There is currently no drop-in substitute for gasoline available. Development of a drop-in gasoline substitute is a high priority in order to reach a significant fraction (>20%) of biofuels in light-duty vehicles by 2030.

The key characteristic of the drop-in fuels is that they are hydrocarbons and contain no oxygen. Since as shown in the figure below, the cellulosic feedstock to be processed to attain the drop-

<sup>12</sup> M. Mintz, J. Han, M. Wang, and C. Saricks Well-to-Wheels Analysis of Landfill Gas-Based Pathways and Their Addition to the GREET Model 2010

in fuels contain a significant fraction (40-50%) of oxygen atoms which must be removed in the biofuel process. It is this requirement that makes the processing to attain drop-in fuels difficult.

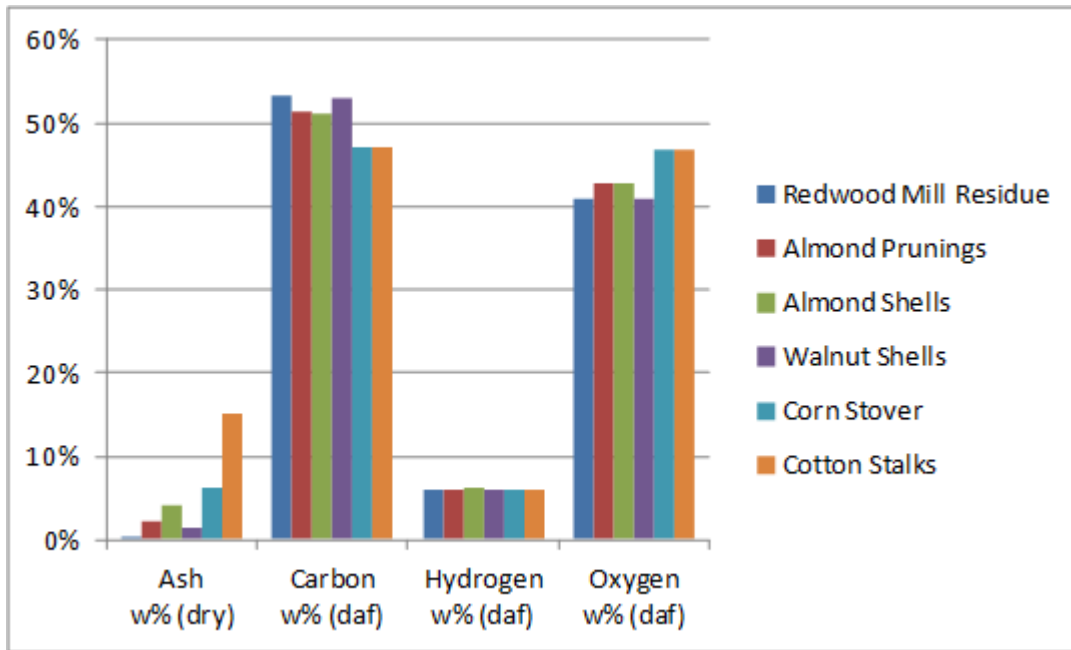

**Figure 7. Chemical composition of various cellulosic feedstocks**

There are a number of projects directed toward development of processes to produce high octane, drop-in bio-gasoline. The processes being used are indicated in the figure below. The feedstock processes are pyrolysis with hydrotreating and gasification to syngas (hydrogen and CO) followed by a chemical process (Fischer-Tropsch) to form the fuels. One of the new pyrolysis approaches being developed by the Gas Technology Institute (GTI) is referred to in the literature as IH<sub>2</sub>. Those processes can produce all the drop-in fuels – gasoline, diesel, and jet fuel – from a number of feedstocks. The IH<sub>2</sub> process will be described in some detail in the following paragraphs.



# Conversion Technologies

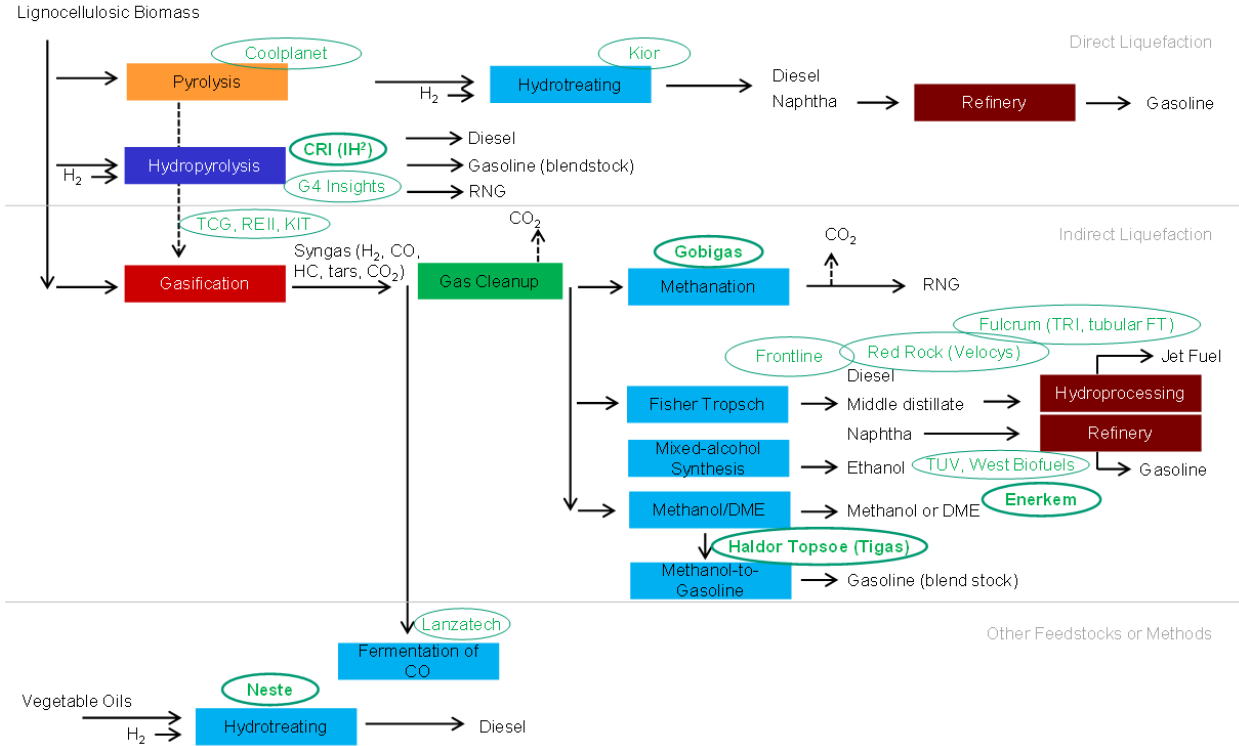

Figure 8. Lignocellulosic biomass to transportation fuel conversion technologies

## The IH<sub>2</sub> process for drop-in biofuels

### Introduction

The IH<sub>2</sub> process is a thermochemical process or series of processes that are integrated in a single process unit for which the biofuel is input and a mixture of gasoline and diesel fuel is output. The processes and hardware are described in detail in two GTI reports to DOE, one of the sponsors of the development. The reports were written by GTI and are available on the internet. The reports are listed below.

1. Biomass to Gasoline and Diesel using Integrated Hydropyrolysis and Hydroconversion (April 1, 2010-December 1, 2012), prepared for the U.S. Department of Energy, PI. Terry Marker, December 2012
2. Long Term Processing using Integrated Hydropyrolysis plus Hydroconversion (IH<sub>2</sub>) for the Production of Gasoline and Diesel from Biomass (January 1, 2011-March 31, 2013), prepare for the U.S. Department of Energy, PI. Terry Marker, December 2012

This technology appears to be suitable for scale-up and can process a wide variety of cellulosic biomass feedstock. Even though the technology has to date only been demonstrated in a 50 kg/day pilot plant at GTI, they have made significant progress in arranging for the scale-up and

commercialization of their technology. They have licensed the technology to CRI/Criterion Catalyst Company, which is member of the Royal Dutch Shell group. CRI is/has developed the catalysts needed in the processes and is continuing their involvement. GTI has also licensed the technology to SynSel Energy of Elmhurst, Ill. as their partner in preparing demonstration projects around the world. The first demonstration project will be in Grenland, Norway with completion of the facility by early 2016. This facility will process 5 metric tons/day of biomass. After the demonstration plant has been operated successfully, SynSel Energy is planning a commercial size IH2 facility in the U.S.

### Review of the IH2 technology

As noted previously, the IH2 processes and system are described in detail in the references cited above. As shown in Figure 9, the conversion of the biomass to hydrocarbon fuels is done in essentially two steps. The first step is pyrolysis in the presence of hydrogen and the second step converts the products of the first step to the fuels by further reaction with hydrogen. Most of the technologies being developed to convert biomass to hydrocarbon fuels start with pyrolysis and then hydrogenate the products. The IH2 technology is particularly attractive because it integrates the various steps into a single unit with the hydrogen needed generated within the unit. The processes are described on the following pages taken from (Canabarro, 2013).

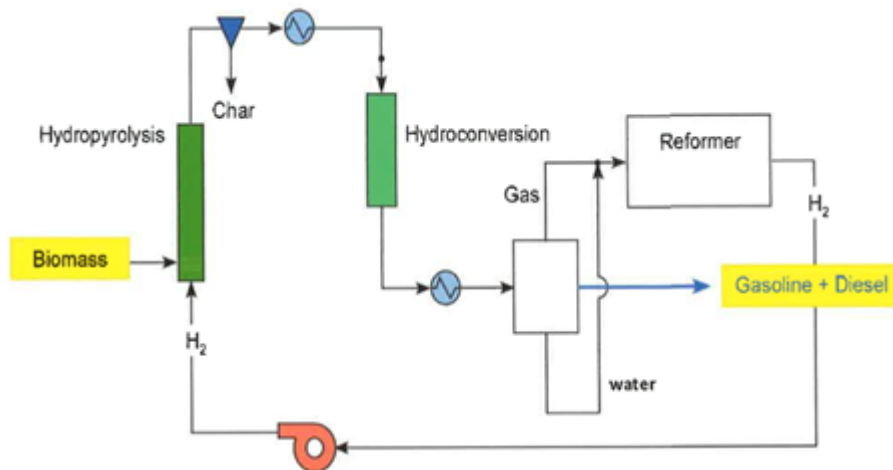
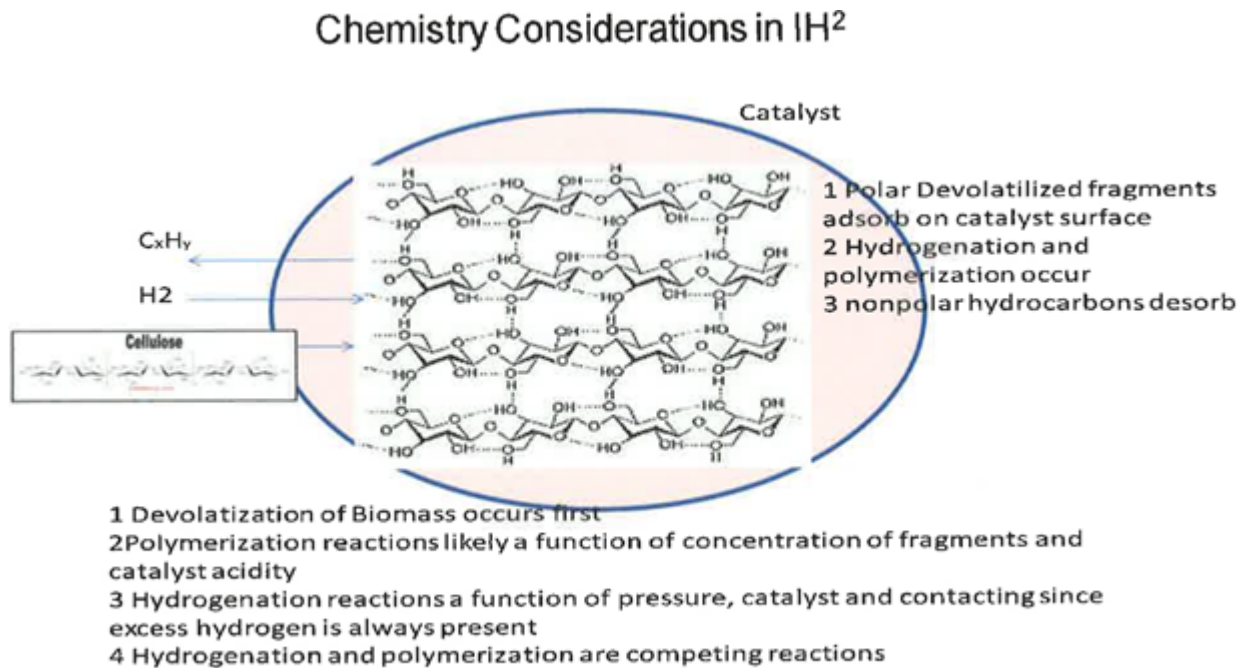

**Figure 9. The IH2 system, showing the overall process flow**

Biomass is converted to gas, liquid and char in the presence of hydrogen in a pressurized fluid-bed hydrolysis stage, the char is removed, and the vapor from this stage is directed to a second stage hydroconversion unit which further removes oxygen and produces deoxygenated gasoline and diesel products. The liquid is condensed and the C<sub>3</sub> gas from the process is sent to an integrated steam reformer. By running at the proper conditions with the proper catalyst, the hydrodeoxygenation and decarboxylation reactions are balanced so the hydrogen required for hydrolysis and hydroconversion is produced in the steam reformer. The hydrolysis

and hydroconversion processes are exothermic and produce high levels of steam. The process steps are carried out at almost the same pressure except for pressure drops through the vessels, so the energy required to compress hydrogen and recirculate it back to the first stage is available from steam produced in the process.

The chemistry of the hydrolysis step is depicted in the figure below. The hydrolysis step is the heart of the IH<sup>2</sup> process and the part which separates it from competing technologies. In the hydrolysis step, the biomass devolatilizes and then the volatile fragments are immediately hydrotreated to remove oxygen and add hydrogen to the structure. Polymerization also occurs since IH<sup>2</sup> products show a wide range of boiling points and chain length. 200-500 psi of hydrogen partial pressure is required for good yields and high oxygen removal. Since excess hydrogen is always present in IH<sup>2</sup>, the rate of hydrodeoxygenation is a function of hydrogen partial pressure. Residence time is also important since the biomass must have sufficient time to devolatilize. Biomass will devolatilize more slowly at high pressure and moderate temperature than would occur in standard pyrolysis conditions.



*Figure 2-Chemistry of Hydrolysis*

**Figure 10. The chemistry of Hydrolysis**

The IH<sup>2</sup> processes produce a mixture of gasoline and diesel with the ratio of the fuels depending on the feedstock used. The ratio varies between about 70% and 50% gasoline. The quality of the fuels and comparison with conventional fossil fuels is shown in the following tables taken from Ref (2). In Table 15, the properties of the biomass derived gasoline are compared with conventional fossil derived gasoline. It appears that the properties and cost of

the biomass-based gasoline compare favorably with the conventional gasoline. In Table 16, the properties of the biomass-based diesel fuel produced from several feedstock are compared with those of conventional diesel fuel. The properties of the biomass -based diesel compare favorably with those of the conventional diesel fuel. Table 17 compares the cost of the biomass-based fuels with the conventional fuels and indicates the costs of the biomass-based fuels are favorable. Table 18 shows that the properties of the biomass-based jet fuel compare favorably with those of conventional jet fuel.

**Table 15. Comparison of IH<sub>2</sub>-50 gasoline from wood with ASTM D4814-10b gasoline specifications**

	Test method	ASTM D4814-10b specification	IH <sup>2</sup> gasoline from wood
Distillation T 10,C max	ASTM D86	70	51
Distillation T 50 C max	ASTM D86	121	89
Distillation T 90 C max	ASTM D86	190	173
Distillation FBP C max	ASTM D86	225	195
Distillation Residue, vol % max	ASTM D86	2	1
Oxidative stability(induction period ) min	ASTM D 525	240	960+
Copper strip corrosion, 3hr @50C merit class	ASTM D 130	1	2A
RVP at 37.8C(100F) kPa,max	ASTM D5191	103	67.4
Sulfur ppm, max	ASTM D 5453	80	40

Based on these analyses it is concluded that IH<sup>2</sup> gasoline is an excellent blending component for gasoline and is close to a R-100 drop in fuel if cut properly. Its value is 100% of that of wholesale gasoline which is essentially \$2.30-\$2.50/gal or \$810-880/ton. This includes no credits for being an advanced biofuel.

This table shows the ratio of the volume of gasoline and diesel fuel varies greatly depending on the feedstock. It appears that wood feedstock from forests yields a good ratio of gasoline.

This review of the GTI IH<sub>2</sub> process and the biomass-based fuels produced using various feedstock indicates that the pyrolysis/conversion process approach can produce fuels of high quality at an attractive price. Even though this technology for producing biofuels is not highly developed at the present time (2015), the work to date seems to show that the technology can produce from cellulosic feedstock both gasoline and diesel suitable for blending with conventional fuels and as drop-in fuels to replace the conventional fuels when the biomass conversion technology is mature and scaled up for commercialization.

**Table 16. IH<sup>2</sup> diesel properties compared to petroleum derived diesel**

Component	IH <sup>2</sup> Diesel from maple (390-700)	IH <sup>2</sup> Diesel from pine (430-700F)	IH <sup>2</sup> Diesel from algae from earlier semi continuous testing (430F-700F)	Typical Diesel from fossil (400-700F)	Typical LCO from Fossil fuel (400-700F)
Wt% Carbon	89.75	89.81	86.11	86.1	87.93
Wt% Hydrogen	10.23	10.19	12.86	13.9	9.45
Wt % Oxygen	nil	nil	nil	nil-	Nil
Wt ppm Sulfur	30	20	46	15(max)	2.6
Wt ppm Nitrogen	170	202	9630		250
Density, g/ml	.936	.952	.851	.820-.845 typical	.960
Cetane Index(D-4737)	27	27	51	40(min)	24
H/C molar ratio	1.37	1.36	1.79	1.94	1.29
Aromatics	83wt%	nm	nm	35 vol%	82wt%
Chloride ppm	<.5ppm	<.5ppm	nm	nil	nil

However the IH<sup>2</sup> diesel compares favorably to petroleum derived light cycle oil (LCO) since IH<sup>2</sup> diesel has similar aromatics content but much less sulfur content than typical LCO. In some petroleum refineries, LCO is upgraded by adding it to a hydrocracker. However in many petroleum refineries, LCO is simply blended into diesel, especially if the LCO meets the sulfur specification for diesel. This is possible because many U.S. refineries are processing more light sweet crude, using oil produced from tight shale formations, which produces high cetane diesel product. This results in cetane give away in the U.S. which means that in the U.S. low sulfur LCO can be readily blended with diesel. In Europe, LCO is more difficult to blend away since they don't process as much light sweet crude and their diesel cetane requirement is 50 minimum.

Given this background, a conservative estimate for the value of IH<sup>2</sup> diesel is that it is \$2-4/bbl (\$.05-.10/gal) less valuable than ULSD (ultra low sulfur diesel) and has a similar value to LCO. This puts IH<sup>2</sup> diesel value at \$2.20-2.45/gallon of \$615-685/ton. This valuation includes no renewable fuel credit.

The overall value of IH<sup>2</sup> combined liquids are therefore \$752-821/ton or \$2.30-2.51/gal. A \$1.00/gal tax credit would increase IH<sup>2</sup> fuels product still further. The value of IH<sup>2</sup> fuel is summarized in Table 17.

**Table 17. Value of IH<sup>2</sup> Gasoline and Diesel Blending Components (not including tax credit)**

	Value of petroleum derived Gasoline	Value of IH <sup>2</sup> gasoline	Value of petroleum derived diesel	Value of petroleum derived LCO	Value of IH <sup>2</sup> Diesel Blending component	Value of Total IH <sup>2</sup> Hydrocarbon Liquids
\$/gal	2.30-2.50	2.30-2.50	2.30-2.50	2.20-2.45	2.20-2.45	2.30-2.51
\$/ton	810-880	810-880	723-786	615-685	615-685	752-821

Jet Fuel is a light subset of diesel fuel derived by cutting the diesel fuel at 535F. A comparison of jet fuel specification and IH<sup>2</sup> jet fuel from wood is shown in Table 18.

**Table 18. Comparison of IH<sup>2</sup> Jet Properties from Wood Feed with Jet Specifications in ASTM 1655-11b**

	Test method	ASTM D1655-11b specification	IH <sup>2</sup> jet from wood
Total acidity,mg KOH/g max	ASTM D 3242	0.1	0.029
Sulfur, wt%, max	ASTM D 2622	0.3	0.0022
Sulfur mercaptan wt% max	ASTM D3227	0.003	0.0016
Flash point, C min	ASTM D 56	38	82
Freeze point, C , max	ASTM D 2386	-40	-70
Viscosity at -20C,cst, max	ASTM D 445	8	7.9
Existent Gum,mg/100ml, max	ASTM D 381	7	4
Conductivity pS/m, min	ASTM D 2625	-47	80
Distillation T10, C , max	ASTM D 86	205	217
Distillation FBP, C , max	ASTM D 86	300	274
Total aromatics, vol%, max	ASTM D1319	25	92.2
Density,at 15C kg/m3, max	ASTM D4052	840	919
Net Heat combustion,MJ/kg, min	ASTM D3338	42.8	41.6
Smoke point mm,min	ASTM D1322	18	3.5
Naphthalenes,vol%,max	ASTM D1840	3	8.44
Copper Strip Corrosion max	ASTM D 130	1	3A

**Yield of IH<sup>2</sup> Biofuels from 2,000 Moisture and Ash Free (MAF) Metric Tons (mt) of Biomass**

IH <sup>2</sup> Biofuel from Different Biomass Types	Yield of IH <sup>2</sup> Gasoline (mt)	Yield of IH <sup>2</sup> Diesel (mt)	Total IH <sup>2</sup> Biofuel Yield (mt)
Microalgae	448	448	996
Cane Bagasse	432	140	572
Corn Stover	320	200	520
Forest Resources	320	200	520

## Flash pyrolysis processes to produce Bio-oil

Another approach to producing gasoline from biomass is to convert the biomass to a bio-oil that can be substituted for petroleum in the oil refinery. This approach, which is known as **refinery coprocessing**, permits cellulosic feedstock to contribute to the production of gasoline, diesel, and aviation jet fuel using conventional refineries. This technology is being developed by Ensyn and UOP with support from Chevron Technology Ventures. Ensyn claims that their technology has been used for over 37 million gallons of commercial production in the last twenty five years.

### Current State-of-the-Art

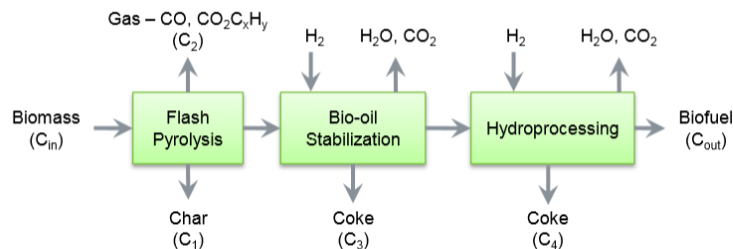

### Next Generation Technology

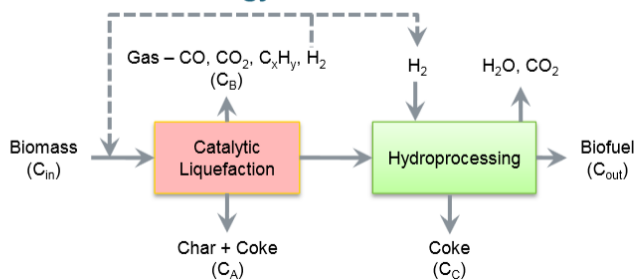

## Bio-oil Production

### Technology Options

- **Fast Pyrolysis**  
(0.1 MPa and  $\sim 500^\circ C$ )
- **Bio-oil Stabilization**  
(10 MPa,  $150-250^\circ C$ )
- **Hydroprocessing**  
(20 MPa,  $300-350^\circ C$ )
- **Catalytic Fast Pyrolysis**  
(0.1 MPa and  $\sim 500^\circ C$ )
- **Hydrothermal Liquefaction**  
( $\sim 20$  MPa and  $\sim 375^\circ C$ )
- **Hydropyrolysis**  
(1-5 MPa ( $H_2$ ) and  $\sim 375^\circ C$ )

Figure 11. Conversion Technologies for Advanced Biofuels- Bio-Oil Production (Dayton, 2012)

None of the technologies for producing drop-in fuels from biomass feedstocks has reached the stage of large scale production and are at best in a demonstration stage.

### 3.5 Feedstocks for various biofuels

#### 3.5.1 Feedstock needed to replace a significant fraction of fossil fuels

It is of interest to estimate the weight (metric tons) of feedstock needed to produce a specified weight of biofuel with the same energy content as one billion gallons of gasoline. Assuming that the average energy content of the feedstock is 20 MJ/kg, the mass (metric tons) of feedstock per bgge produced is

$$\text{Mass (metric tons)/bgge} = 6.6/\eta_{\text{eff}} \times 10^6, \eta_{\text{eff}} \text{ is the process efficiency}$$

For a process efficiency of 50%, the feedstock required is 13.2 million tons per bgge. Hence feedstock requirements will be in millions of metric tons to replace a significant fraction of either gasoline or diesel used. This is an approximate relationship because most of the processes require additional energy added or the injection of hydrogen during the process. This affects both the efficiency of the process and the GHG generated. The feedstock requirements for various biofuels are given in Table 19.

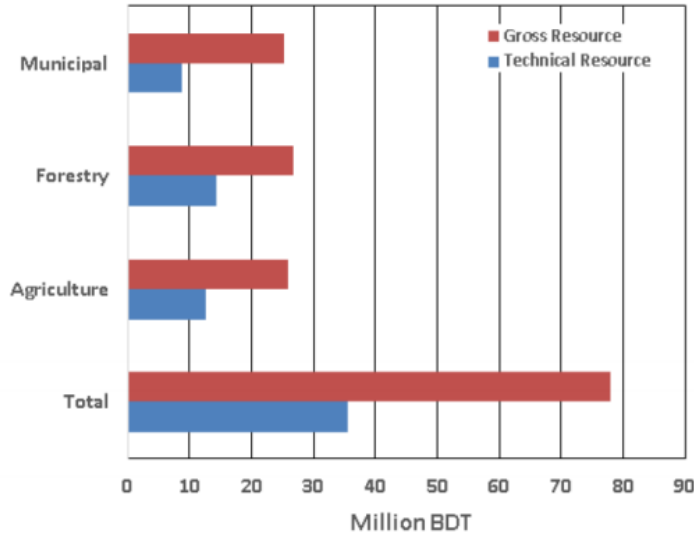

**Table 19. Feedstock requirements for various biofuels**

Biofuel	Energy content	Feedstock	Energy content of feedstock (MJ/kg)	Dry metric tons/yr/bgge (million ton)	2014 Tons/yr (available in California)	2014 Tons/yr (available in U.S.)	Reference source
ethanol	81.5 MJ/gal 27.2 MJ/kg	Corn Cellulosic	18 18	14.6 14.6	80x10 <sup>6</sup> pot. 30x10 <sup>6</sup> avail To be used for all biofuels	250x10 <sup>6</sup> avail	CBMC UCBerkeley
biodiesel	126 MJ/gal 38 MJ/kg	Cooking oils Soy beans Cellulosic	39.5 39.5 18	6.7 6.7 14.6	80x10 <sup>6</sup> pot. 30x10 <sup>6</sup> avail To be used for all biofuels		CBMC
Renewable diesel	130 MJ/gal 44.2 MJ/kg	Cooking oils Soy beans Cellulosic	39.5 39.5 18	6.7 6.7 14.6	80x10 <sup>6</sup> pot. 30x10 <sup>6</sup> avail To be used for all biofuels To be used for all biofuels		CBMC
Drop-in gasoline	120 MJ/gal 42 MJ/kg	Woody mass	18	14.6	25x10 <sup>6</sup> potential	250x10 <sup>6</sup> avail	CBMC UCBerkeley
Renewable natural gas	1.1 MJ/scf	Wastes and landfills	NA	125,000 bscf/bgge	93 bscf (potential)	2x10 <sup>6</sup>	CBMC; NREL July 2014
Hydrogen from biogas	120 MJ/kg	Wastes and landfills	NA	1 bkgH <sub>2</sub> /bgge		1.6x10 <sup>6</sup> 1.6 bgge/yr	NREL July 2014

### 3.5.2 Feedstock availability

The volume of feedstock available depends on whether we are referring to Gross vs Technical vs Commercial. Gross refers to anything that can theoretically (on paper) be converted to biofuel, but typically less than 50% gross resource is technically available because of “inaccessible or sensitive areas, losses from harvesting, and maintaining soil quality” (see Table 19) or limitations of the technical processes.



Williams, R. B., B. M. Jenkins and S. R. Kaffka (2015). An Assessment of Biomass Resources in California, 2013 Data - DRAFT. CEC PIER Contract 500-11-020, California Biomass Collaborative.

**Figure 12. Biomass resources in California, gross vs. technical**

Not all technical potential will then be available due to economics. How much of it will be commercial depends on the price the market is willing to pay for the potential products, which affects the economics of the feedstock procurement. For example, Figure 1 from the most recent (2011) update to ORNL’s Billion Ton Biomass Report (ORNL, 2011) shows supply curves for logging residues which give the amount of feedstock based on how much a potential biofuel producer would pay per dry ton.

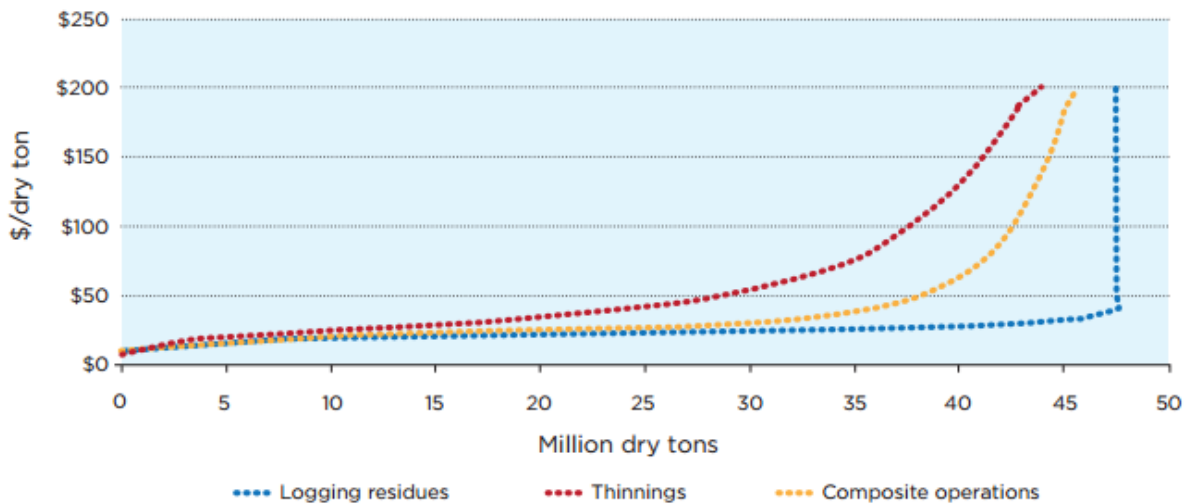

**Figure 13. National supply curves for logging residues, thinning, and composite from timberland**

Similarly, for agricultural residues, the estimation of availability of feedstock depends on many assumptions such as fertilizer use, harvest ratio and others that affect the final amount of residue per acre (i.e., density), which will affect costs of harvesting as Figure 14 shows.

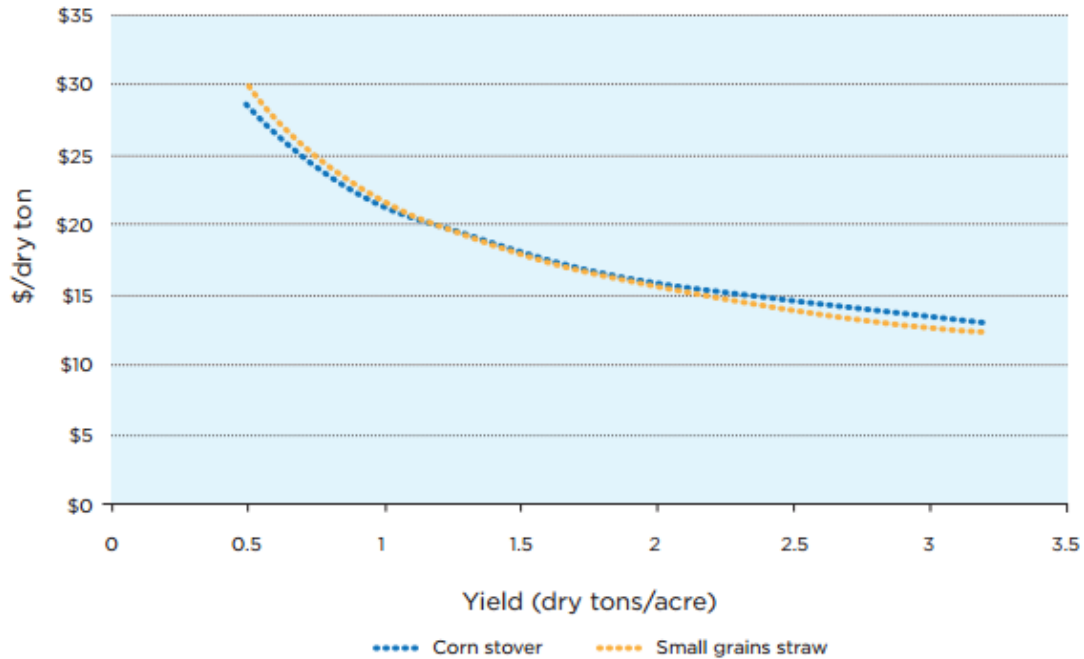

**Figure 14. Collection costs to the field edge for corn stover and small grains residue**

Figure 15. shows supply curves for residues of major crops under different prices under ORNL baseline assumptions (i.e., current average crop yield).

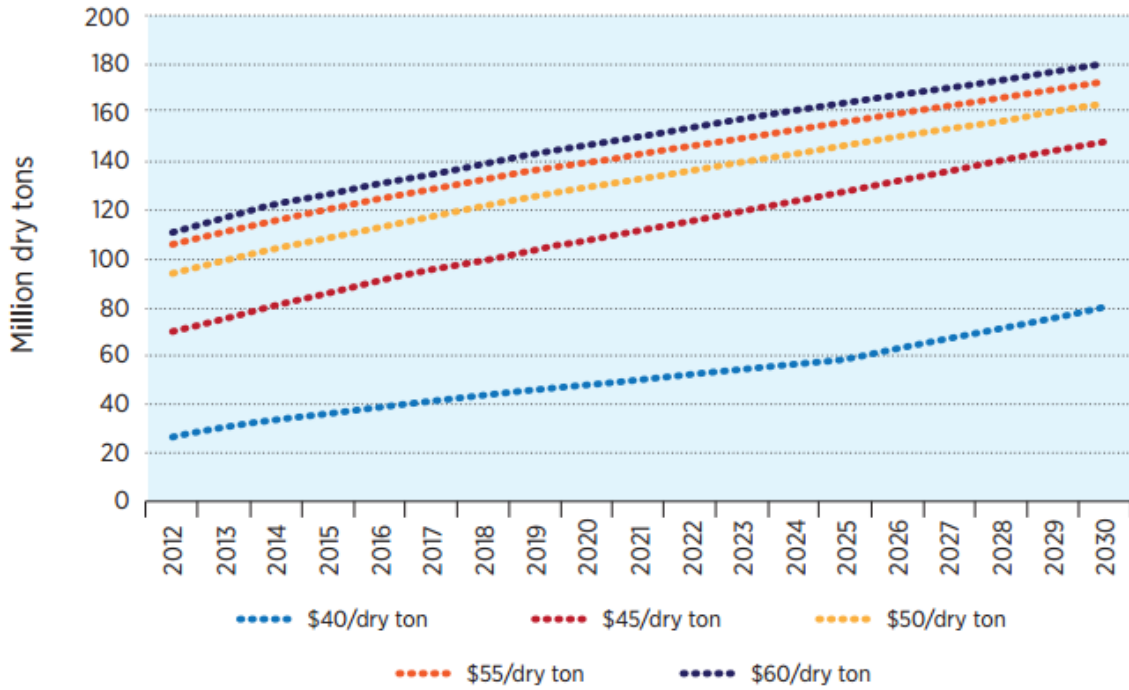

**Figure 15. Total available supply of residues of major crops after sustainability constraints are met at various prices under baseline assumptions**

A UC Davis study for California investigated various agricultural crops as feedstocks for biofuels and biogas.

Table shows in California there are many feedstock crop possibilities on an agro-ecological basis (Kaffka, 2015). The following table shows the estimates by Kaffka et al. given specific cost assumptions.

**Table 20. Current and potential California alternative fuel production estimates (Kaffka, 2015)**

Current source	In-state million gallons /year)	Estimated feedstock cost \$/gge	Comments
Grain-based ethanol	205		Mostly corn grain based, currently
Biodiesel	55-60		Mostly FOG (waste fat, oil, greases)
<b>Potential new source</b>			
New agricultural crops for ethanol	150	0.9-3.9	Grain sorghum, sugarbeets, sugarcane and energy cane

Current source	In-state million gallons /year)	Estimated feedstock cost \$/gge	Comments
New agricultural crops for biodiesel	75	2.82	oilseeds(canola, camelina)
Agricultural residues - rice straw	6.8		as biogas
Agricultural residues - dairy manure	155		as biogas
Additional FOG (fat, oil and grease)	40		Industry estimate
Biodiesel from corn oil			
<b>Total</b>			
Ethanol	355		
Biodiesel	175		
Biogas	160		

From feedstock availability and assumed fuel yields, the amount of biofuel or biogas that can potentially be produced can be estimated. However, biofuel and biomethane potential in

**Table 21. Biofuel and biomethane potential in California (amounts are not additive, Feb 2016)**

Tables 20 and 21 are not additive. A feedstock can be used to produce either, but not both, biofuels; market conditions will determine which biofuel will be produced from a particular feedstock.

**Table 21. Biofuel and biomethane potential in California (amounts are not additive, Feb 2016)**

Feedstock	Amount Technically Available <sup>13</sup>	Biomethane Potential (billion cubic feet)	Biofuel Potential (million gge)
Agricultural Residue (Lignocellulosic)	5.3 MM BDT	51.8	264
Animal Manure (Dairy & Poultry)	3.4 MM BDT	19.5	168
Fats, Oils and Greases	207,000 tons	1.9	56
Forestry and Forest Product Residue	14.2 MM BDT	139	710
Landfill Gas	106 BCF	53	457
Municipal Solid Waste (food, leaves, grass fraction)	1.2 MM BDT	12.7	109
Municipal Solid Waste (lignocellulosic fraction)	6.7 MM BDT	65.9	336
Waste Water Treatment Plants	11.8 BCF	7.7	66
Total		351	2,167

<sup>13</sup> No dedicated biomass crops were considered for this analysis

## 4. Findings for Session #2: Critical barriers for commercialization of biofuels and biomethane

The commercialization of liquid biofuels and biomethane faces several critical barriers as shown in Figure 16. There are a number of sources of these risks – uncertainties in the technology, competition with incumbent companies and products/ fuels, changing government regulations, changing economic conditions, uncertainty in the availability and cost of feedstock, etc. These risks will be considered separately in the following sections.

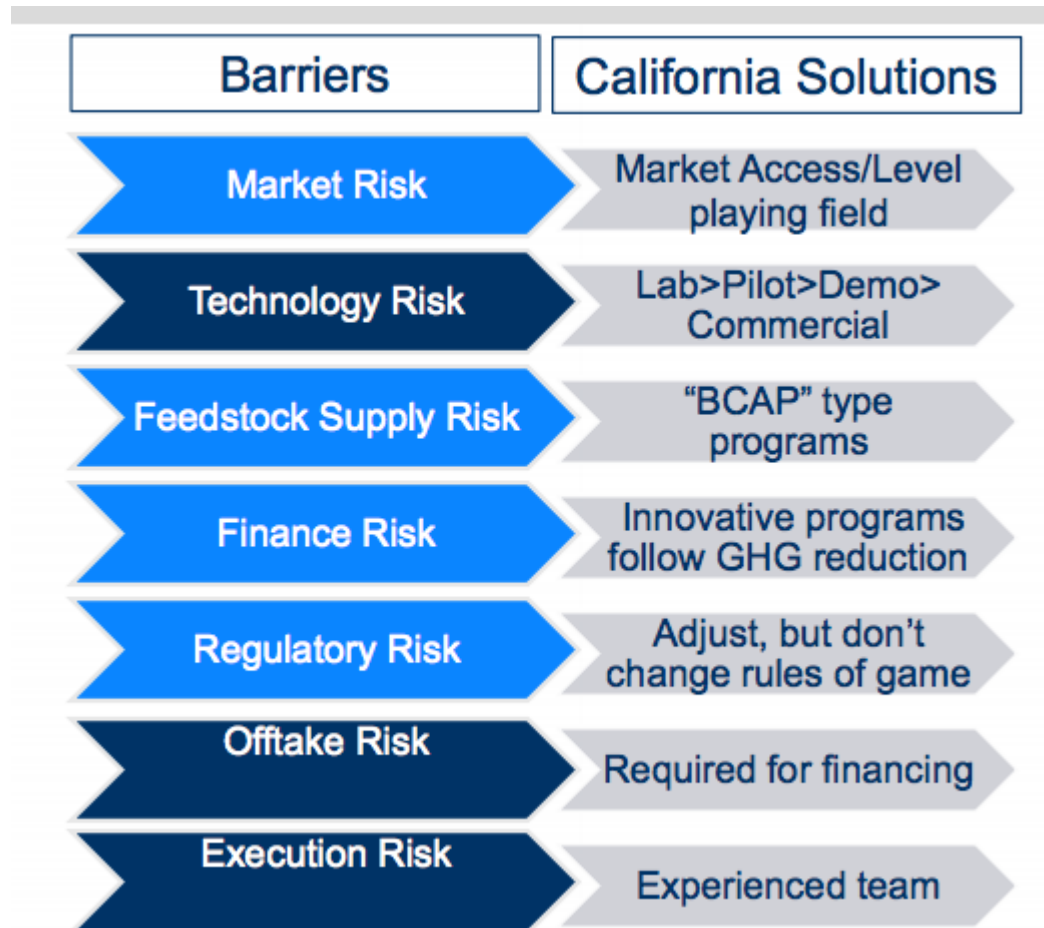

Figure 16. Critical Barriers and Risk Mitigation Solutions

### 4.1 Capital and R&D funding is uncertainty

The uncertainty that a technology for producing biofuels will be efficient and economically viable is one of the likely barriers for successful commercialization. Maintaining adequate funding during the R&D and the pilot production stages is particularly difficult. These stages can require a number of years and funding agencies and investors can become impatient when progress appears to be slow and difficult for them to assess. Scaling up the production



processes for large scale production is very expensive, requiring large capital investments. In many situations, in fact, “financial engineering” can be more critical than “technical engineering” in the project succeeding.

Biofuel and biomethane projects seem to be lacking in funding at the present time. If a project has a high probability of success, investors are not necessarily deterred by the high capital costs, but they find biofuel and biomethane projects to be riskier than their typical investments for several reasons (discussed in later sections). One reason for this perception is that most of the oil companies, who are making large profits and have large profits to reinvest, do not see the need for biofuels development and continue to make their investments in more conventional energy resources.

#### 4.2 Uncertainty in Government policies and regulations

The number one barrier to investment in biofuels, as discussed at the September 17 workshop, is policy uncertainty, particularly how long a policy might remain in effect. Uncertainties from multiple levels of government were presented by speakers at the workshop (e.g., Elkind, 2015):

- EPA RFS (Renewable Fuel Standard)
- LCFS (Low Carbon Fuel Standard) post 2020
- Cap-and-trade eligibility

Speakers at the workshop (e.g., Williams, 2015) provided additional insights from the industry’s perspective. In renewable natural gas (RNG) transportation fuel projects, uncertainty of duration of RFS2 and California LCFS programs resulted in the obligated parties’ unwillingness to commit to firm pricing for purchase of RNG, since the value of RINS and LCFS credits beyond 2022 are uncertain (Figure 17). A short duration RNG Sales Agreement with unpredictable pricing will not support needed project finance debt for RNG projects or any other large biofuels projects. Policy uncertainties affect the revenue predictability, and hence profitability, for biofuels projects.

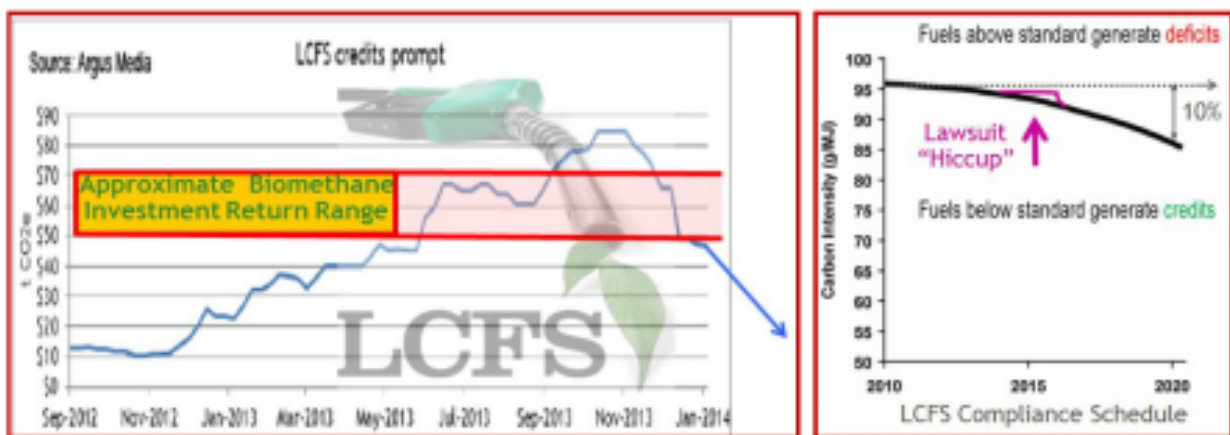

(a)

**Monthly LCFS Credit Transfer Activity Report for February 2016**

Posted on 3/8/2016

<b>Time Period</b>	<b>Transfers<sup>1 3</sup> (number)</b>	<b>Total Volume<sup>1 2 3</sup> (credits-MTs)</b>	<b>Avg. Price<sup>1 3 4</sup> (\$ per Credit)</b>
<b>February 2016</b>	<b>34</b>	<b>139,000</b>	<b>\$122</b>
<b><u>Previous Three Months</u></b>			
<b>January 2016</b>	<b>58</b>	<b>206,000</b>	<b>\$105</b>
<b>December 2015</b>	<b>90</b>	<b>723,000</b>	<b>\$96</b>
<b>November 2015</b>	<b>97</b>	<b>435,000</b>	<b>\$86</b>
<b><u>Previous Three Quarters</u></b>			
<b>Q4 2015</b>	<b>223</b>	<b>1,287,000</b>	<b>\$90</b>
<b>Q3 2015</b>	<b>156</b>	<b>747,000</b>	<b>\$53</b>
<b>Q2 2015</b>	<b>102</b>	<b>474,000</b>	<b>\$24</b>
<b><u>Previous Three Years</u></b>			
<b>CY 2015</b>	<b>578</b>	<b>2,852,000</b>	<b>\$62</b>
<b>CY 2014</b>	<b>304</b>	<b>1,667,000</b>	<b>\$31</b>
<b>CY 2013</b>	<b>202</b>	<b>887,000</b>	<b>\$55</b>

**Price Range in February 2016<sup>1 3 4</sup> = \$62 to \$127 per Credit**

(b)

<sup>1</sup>Includes transfers that were proposed and completed as well as those that were proposed and still pending buyer's confirmation in the LCFS Reporting Tool and Credit Bank & Transfer System (LRT-CBTS).

<sup>2</sup>Rounded to the nearest thousand.

<sup>3</sup>Excludes intra-company credit transfers with a zero price.

<sup>4</sup>Some credit transfers were reported with a zero or near-zero price. The price shown excludes these transfers.

<sup>5</sup>Data excludes transfers that were proposed but were still pending buyer's confirmation in the LRT-CBTS.

**Figure 17. Uncertainty of LCFS and RINS credits value**

### 4.3 Uncertainty in feedstock availability, source, and cost

Various workshop attendees (e.g., Foster, 2015) mentioned that biofuel production faces feedstock supply risks and suggested there needs to be more “BCAP” (Biomass Crop Assistance Program, <http://www.fsa.usda.gov/programs-and-services/energy-programs/BCAP/index>) type programs to financially assist “owners and operators of agricultural and non-industrial private forest land who wish to establish, produce, and deliver biomass feedstocks” (Figure 18). (USDA, 2015)

Reinhard Seiser noted that near-term feedstock barriers have to do with scale and logistics. Biomass is mostly sparsely distributed, and biomass facilities are small in scale. In contrast, refineries are concentrated and large, and fuel specifications for gasoline are tight. There is the need for a logistics infrastructure that combines biomass processing streams, and growing facility scales as energy is concentrated. The diagram below is an example:

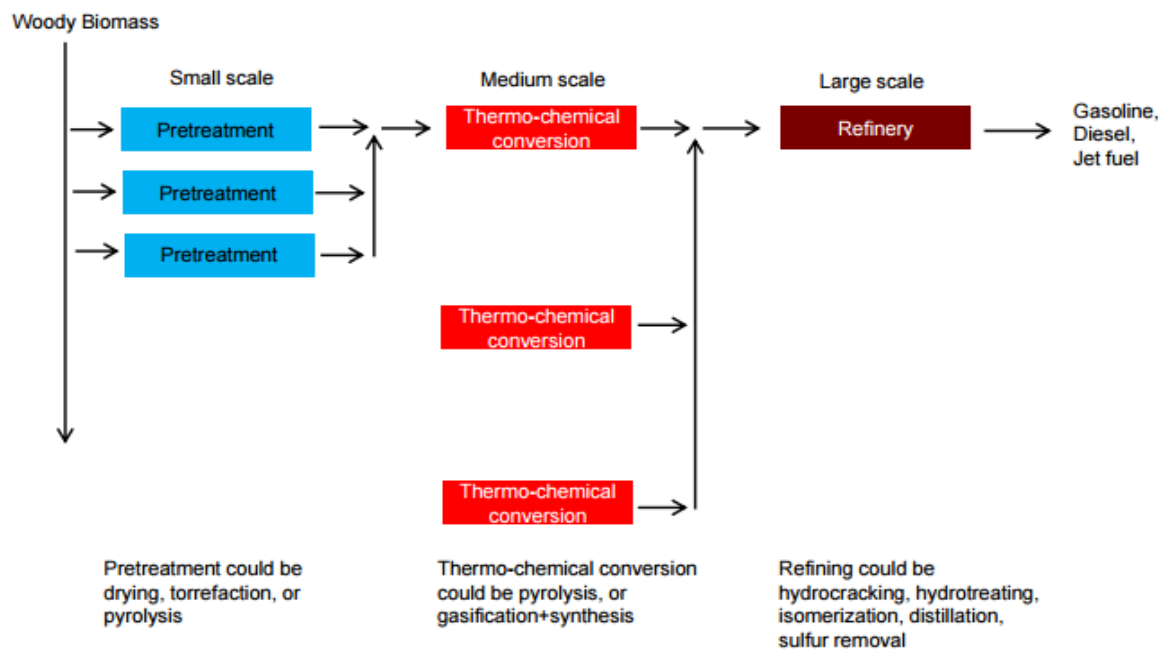

Figure 18. An example of combined biomass processing streams and logistics infrastructure

### 4.4 Barriers for drop-in liquid fuels

Gasoline is the fuel used currently in the greatest quantity by a large factor. Hence, replacing gasoline in the current on road fleet with a drop-in biomass based fuel would be the fastest way to reduce GHGs for the current fleet. Hence, workshop participants stated that there should be a high priority on the development of technology to produce and market drop-in gasoline from biomass.

A related issue is the blending of ethanol with gasoline. Ethanol is the most available drop-in fuel for light-duty vehicles. Currently nearly all gasoline sold contains 10% ethanol. Most of this ethanol is produced from corn, which limits the GHG reduction of this ethanol in gasoline. The total ethanol used is limited by the 10% blending wall, which is the primary barrier to using more ethanol. The barrier could be raised to 15% if there could be agreement on it with the auto industry. More ethanol could also be used if there were a larger market for E85 for use in bi-fuel vehicles. Another barrier to the use of ethanol to reduce GHG is that most of the ethanol is produced from corn rather than cellulosic bio-materials. The reason for this is the slow development of processes for the production of ethanol from cellulosic materials and the resultant high cost of the ethanol.

There are a number of projects underway in the U.S. and Europe to develop technology to produce drop-in gasoline from cellulosic biomass. However, progress in those developments has been slow and the cost of moving from laboratory pilot hardware systems to demonstration scale systems is expensive. The cost of the scale-up from pilot to demonstration to commercial scale is illustrated in Figure 19. In addition to cost, the risks of failure are high due to the high pressure and temperature of the processes and the need for the use of high cost catalysts, which can have limited life under these operating conditions. Consequently, at the present time there are no commercial scale drop-in gasoline facilities in operation and none seem to be planned for the near-future. In summary, the development of facilities to produce biomass based gasoline has been slow and likely will continue to be slow in the future.

## Financial Barrier: Scale-up Risk

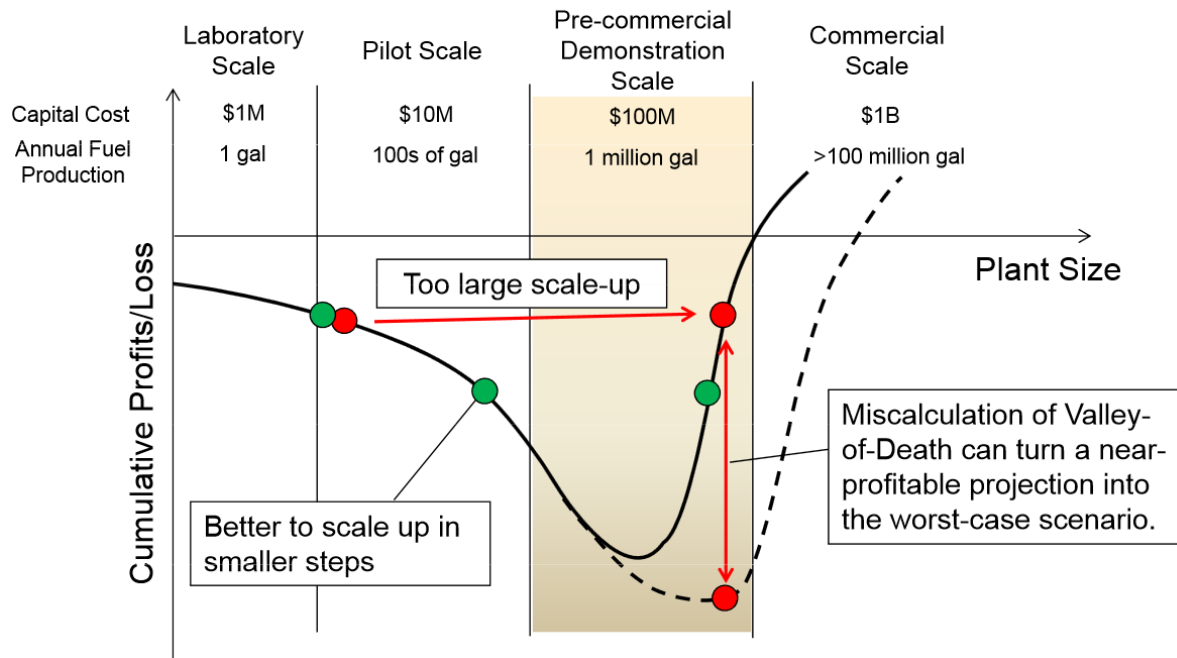

Range Fuels: 5 tons/day → 125 tons/day (Phase1) ... failed  
 Kior: 50 times from demonstration to commercial ... on hold

Figure 19. Financial barrier: scale-up risk

### 4.5 Barriers for renewable natural gas

In the case of RNG, there is the low cost of fossil natural gas with which RNG must compete and for which RINS and LCFS credits help reduce the cost to the consumer. Another factor that affects profitability is the variability and uncertainty of tipping fees for solid waste. High tipping fees are becoming more common and that favors RNG.

# Revenue Components for Different Sources of RNG as Transportation Fuel

RNG Source	Tipping Fee	Natural Gas Commodity Price	RINS	LCFS
Landfill	No	Yes	Yes	Yes
WWTP	No	Yes	Yes	Yes
Organic digester & co-digester*	Yes	Yes	Yes	Yes
Organics Gasification to Produce Syngas Upgraded to RNG*	Yes	Yes	Yes	Yes

\* California policy to divert organics from landfills will cause shift in production of RNG from landfills to organic digesters & gasification-to-syngas-to RNG projects. More expensive disposal costs for waste will result since new infrastructure must be financed.

**Figure 20. Revenue components for different source of RNG as transportation fuel**

There are other factors than the high cost of producing RNG that make it difficult for RNG to compete with fossil diesel fuel. There is, on one side, the logistics of transporting and storing a fuel that is a gas and therefore with low volumetric energy density. It must be compressed or liquefied. In the case of biomethane as in the case of fossil natural gas, the liquefaction option is more expensive but might be required if higher density fuel (i.e., higher driving range) are required. These various aspects of RNG revenues are summarized in Figure 20.

The additional expense in storage and the fuel system makes natural gas and RNG fueled trucks more expensive than incumbent diesel trucks. Fuel cost savings can offset this additional cost. Another issue of natural gas trucks is that they use spark ignition engines which are less efficient than the compression ignition engines used in diesel fueled trucks making it more difficult to get fuel cost savings. Another barrier that was mentioned at the workshop is the slow certification process for new natural gas engines.

One solution suggested at the workshop was to repower existing diesel trucks to CNG with remanufactured CNG engines. The total conversion costs are less than the costs of new diesel trucks and approximately one half of a new CNG truck.

Access to market is key in RNG, and currently, SoCal Gas’s Rule 30 and Pacific Gas & Electric’s Rule 21, make it difficult for RNG to be injected in the pipeline and is therefore restricted to nearby consumers, which may or may not exist.

## **5. Finds for Session #3: Ideas and solutions to overcome barriers**

### **5.1 Ways to maintain continuity of government regulations, incentives, and R&D funding**

The key issue, expressed by workshop participants, is that state and federal governments do not make a sufficiently clear, continuing, long-term commitment to the commercialization of biofuels as a critical means of reducing GHGs from vehicles of various types. Workshop participants stated repeatedly that regulations and incentives should function with the free market in the background, but the development of biofuel technology and sales of the fuels should not ebb and flow in response to free market forces (i.e. fossil energy prices). The regulations and incentives should reflect primarily the need for progress in reducing GHGs and hence be in place for long periods of time (10-20 years) without the possibility, or fear, of cancellation or significant weakening. Regulations should be coordinated so that complying with regulations from one agency are not made more difficult or less effective due to regulations from another agency. It was suggested at the workshop that a high level task force be set up in California to coordinate all the state regulations related to GHG reduction.

Particular suggestions of what could be done are the following. At the Federal level, the RFS alternative fuel requirement for each year and related incentives and price supports, according to stakeholders, should be set to promote growth in the biofuels industries favoring those fuels thought to be most critical for GHG reductions. Any tax credits for biofuel development and related facilities should remain in place for 10-20 years (an adequate time period for the development of biofuels technologies). Government R&D funding should be concentrated on projects that, if successful, would attract private funding for the demonstration and commercialization stages. More diligent vetting of projects is key so that projects of little chance of success or minimal importance are not funded.

Other key regulations are those related to the LCFS and information concerning the carbon intensity of various alternative fuels, feedstocks, production processes, and vehicle end uses. The fuel quantity targets and carbon intensity values set by California have a strong influence on projects undertaken and funded nationwide. Hence these targets and values should be set in a systematic manner over an extended period of years so that developers of biofuel technology and those that finance those developments can be confident that the ground rules will not change during the development. It is critical that the regulations related to the LCFS and the RFS are consistent and coordinated to support biofuels production in the long-term as well as in the short-term.

### **5.2 Ways to structure incentives and government policies to accelerate improvements in technology, scale-up of projects, and feedstock availability and flexibility**

The discussion of government incentives and policies in the workshop covered a broad range of issues. The most important issue is consistency of funding and regulatory programs. Without consistency industry can struggle to receive private investment and meet regulatory

compliance. The sections below discuss particular issues and potential solutions for both government incentives and policies.

## **Incentives**

AB 1826 helps secure feedstock supplies and increase tipping fees, which help make project economics more attractive. Presently enforcement is not clear, but it is essential for project successful commercialization.

CEC grant funding, according to stakeholders, should fund high risk R&D and demonstrations for technologies that could be very attractive in reducing GHG even if the economic viability is uncertain at the outset of the project. Distribution of the funds must be timely in order not to adversely affect project progress and scheduling. There was general consensus among stakeholders that the CEC AB118/AB8 funding fills a needed gap in the commercialization spectrum for alternative fuels and vehicles.

Cal Recycle loans and grant funding (RMDZ program) provides low interest loans for anaerobic digestion projects. The release of funding has been slowed by legislative action. Funding must be available when expected so project managers can plan effectively.

RINS and LCFS credits can add revenue to projects making them more economically attractive. Financial partners often do not include these credits when they evaluate projects for funding because the future of these credits is uncertain and the credit pricing fluctuates significantly. In order to help companies secure financial partner funding, RINS and LCFS credits should be set long term through the legislature and fixed for periods of at least 10 years.

There are tax incentives for electricity but not for transportation fuels. As a result, biofuel technology applications tend to move toward electricity rather than to transportation. Assuming we would like to shift the incentives more to biofuels in transportation, there should be tax incentives for renewable transportation fuels.

The ARFVTP program does not allocate enough funding to biofuels, according to workshop participants, even though biofuels produce the majority of program benefits and generate most of the LCFS credits.

A biofuel funding initiative, which would include in-state production incentives and an infrastructure expansion, was proposed at the workshop and was widely supported. Funds could be allocated based on CalEnviroScreen scoring.

State and federal funding should be better integrated with private capital according to stakeholders. Mechanisms could be, in the view of workshop participants, put in place to leverage public funding to create synergies between the two. Government funding agencies should work with private funders to identify opportunities, vet technologies, and oversee



management to enhance the effectiveness of the project funding.

### **Government Policies**

Stakeholders agreed that it is critical to have consistent, strong, reliable, and coordinated government policies to send the message to fuels industry that they can rely on these policies when planning projects.

Compliance policies should be coordinated across all relevant agencies. For example, the Clean Air Act and the California Environmental Quality Act (CEQA) require agencies to identify the significant environmental impacts of projects and to ensure that negative impacts are avoided or mitigated. Building codes, program rules, and reporting can change frequently and can make compliance extremely difficult.

One solution to coordinating and producing more consistent government policies suggested by workshop participants is the creation of a high-level biofuels task force. The task force would interact with all relevant government agencies which oversee environmental policies and help to eliminate barriers between these agencies. Industry participation on the taskforce would be imperative.

Infrastructure must be developed to work well with the existing transportation fuels industry. Most renewable transportation fuel is blended with fossil fuels (e.g. ethanol in gasoline and biodiesel in fossil diesel fuel). To increase renewable fuel blending, stakeholders indicated that government should invest in storage and blending infrastructure. They also stated that government should work with the existing petroleum and natural gas industries to find solutions to the barriers to blending.

The EPA sets renewable fuel targets/regulations well below total production capacity, according to stakeholders; the targets should be set close to what the industry can actually produce. The California LCFS is performance based, but the Renewable Fuel Standard (RFS) is not. The RFS should be changed to be based on performance according to workshop participants.

### **5.3 Ways to improve the business climate for biofuel commercialization by increasing private investment, oil industry involvement, and general economic profitability**

The following recommendations to improve the business climate for biofuels are based on suggestions by participants at the workshop:

- California state agencies could guarantee 90% of biofuel project asset-secured debt (whether bonds or commercial debt) used to finance up to 80% of capital expenditures and related costs for the projects. Require a project Debt Service Coverage Ratio of 1.2:1 to qualify for state agency guarantee. Make the state credit rating available to projects without immediate, or perhaps any, use of tax dollars.
- Obligated parties under the LCFS should willing to enter into 15 year RNG Purchase

Agreements with a formula for pricing RINS and LCFS credits (as opposed to fixed price) and with “regulatory out” as to RINS if RFS2 program terminates and as to LCFS credits if the LCFS program in California terminates.

- Loan guarantees would support RNG projects that would meet California objectives of reducing the number of fossil fueled vehicles on road and the adoption of alternative fueled vehicles, such as ethanol/CNG/LNG.
- Greater state funding/support, including cap-and-trade auction revenue, for projects that benefit in-state biofuel production.
- Offer of financial incentives for fuel station operators to offer for sale more biofuels
- Studies to optimize attainment of nitrogen oxides, greenhouse gas, and petroleum fuel reduction goals
- Improve access and financial support for in-state feedstock production needed for low carbon intensity biofuel production.
- Develop well thought-out programs for tradable fuel credits for low carbon fuels and administer them in a consistent manner
- Target specific biofuel goals with grants/funding that support the development of technologies for low carbon biofuels
- Provide loans, rebates, and tax credits to incentivize biofuel commercialization.
- Programs must have procedural certainty before they are implemented
- State and federal funding should be better integrated with private investment. There should be mechanisms in place to leverage public funding with private investments to create synergy between the two. This would apply to identifying opportunities, vetting technologies, and overseeing management to ensure effectiveness.

#### **5.4 Ways to improve the carbon intensity and long-term availability of feedstocks for low carbon fuels**

A consistent, clear approach to determining the carbon intensity of biofuels of all types is needed. One approach is termed “counterfactual”- that is, make comparisons of the GHG emissions if no biofuel is produced vs. what happens if biofuels are produced. These comparisons should include consideration of alternate ways of producing/utilizing the feedstock when that is appropriate.

It is important to have a rational, transparent approach to determining the carbon intensity of feedstock and biofuels that is applicable as technologies and policies change. This will improve both the reliability of carbon intensity estimates and the availability of feedstock.

In the case of biogas, applying the counterfactual approach is extremely favorable as it can even make the carbon intensity biogas negative. If no biogas were collected, carbon would leak to the atmosphere from decaying mass. By creating the biogas pathways, this carbon is collected and put to useful work. The counterfactual results vary across feedstocks. In the case of landfills and wastewater treatment plants, most regulations require producers to flare the biogas, which is better in the short term for the climate than just venting it. Flaring converts methane to

carbon dioxide. Therefore, a tradeoff happens where less powerful but longer lived CO<sub>2</sub> is emitted instead of more powerful and short term methane. In the case of manure, where no flaring is possible, the gas would just be leaked into the atmosphere. The counterfactual result here would be methane (not CO<sub>2</sub>) emitted to the atmosphere.

Landfills are required to recover and dispose of the landfill gas to reduce the emissions of methane and other gases, but collection is not always practical. The Agency for Toxic Substances and Disease Registry estimated that only landfills larger than 35 acres and 35 feet deep can usefully collect landfill gas. The California Biomass Collaborative lists 79 landfill energy projects in California with the potential to add an additional 32 as of January 2014.

In the case of WWTP (Waste Water Treatment Plants), the solid waste produced from the treatment process can be fed into anaerobic digesters to produce biogas. In California there are roughly 140 WWTP that include anaerobic digesters (US EPA 2013). Many of these plants utilize the biogas to produce electricity and recently some plants have begun to produce biogas for use in on-site NG vehicles. The counterfactual result for these plants is either vented (if no digester is in place), or flared/used for electricity (if digester is in place). These counterfactual results affect differently the carbon intensity of WWTP biogas.

The counterfactual result for the manure biogas pathway is carbon leaked to the atmosphere. Anaerobic digesters can reduce methane emissions from manure by 60 – 70%. However, UCD studies show that manure biogas is among the least likely biogas sources to be commercialized.

The counterfactual result for forest and agricultural residue sourced biogas is either rotting dead wood or agricultural residues left to decompose or be burned. These residues can be collected and processed using thermochemical processes (gasification) to produce biogas. If these residues are used to produce liquid biofuels, the same counterfactuals apply. However it might be preferable to convert to biogas rather than to liquid biofuel given that the process is simpler and the inefficiencies attached to each potential conversion step are avoided.

Turning energy crops (rather than residues) into biofuels is a little simpler but a favorable carbon intensity can become unfavorable if indirect land use change is experienced and it results in higher emissions of carbon. For example, burning forests or farm land that otherwise would act as a carbon sink can result in high indirect carbon emissions for the biofuels produced from that land. Keeping biofuel's carbon intensity low requires making sure the indirect land use changes are minimal.

Another aspect that can greatly increase the carbon intensity of a biofuel is the ratio of energy-input to energy output (E<sub>i</sub>:E<sub>o</sub>). Lower ratios are better. This ratio is dependent on 1) mechanization of the planting and harvest of the crop and how much chemical fertilizer is needed, 2) the feedstock/biomass yield to biofuel, and 3) the energy yield of the biofuel. Minimizing the first and maximizing the second and third will improve the E<sub>i</sub>:E<sub>o</sub> ratio. This is why sugarcane ethanol from Brazil has significantly lower carbon intensity than American corn

ethanol. The former has low energy inputs (mostly human labor) and high sugar yields (thus high ethanol yields), and the latter is highly mechanized (high energy inputs) and has lower sugar content (lower ethanol yields). If cellulosic biofuels become commercialized, they would be equivalent to using more of the biomass that grows naturally. Therefore, the ratio of  $E_i:E_o$  would also decrease. For this reason cellulosic biofuels will have lower carbon intensity than the first generation biofuels like corn.

From this perspective, the amount of low carbon intensity biofuels available will probably be limited. The very low (or even negative) carbon intensity biofuel/biomass combinations only exist when the biofuel is produced from wastes. For the non-waste based biofuels, cellulosic based biofuels will likely be preferred to starchy/sugar based biofuels but cellulosic processes have not yet been commercialized.

In summary, the lowest carbon intensity biogas/biofuels will be produced from wastes. For non-waste feedstocks, it is important to minimize land use change that result in a net release of carbon. Finally, for any feedstock/biofuel/biogas case, inefficiencies should be eliminated in each conversion step, because conversion yields are the normalizing factor in the estimation of the carbon intensity.

### **5.5 Ways to accelerate the development of technology for biofuels, especially drop-in bio-gasoline and diesel, from cellulosic feedstocks**

The development of technology to produce drop-in, hydrocarbon biofuels has been slow, and at the present time there is no significant production of drop-in gasoline or aviation jet fuel. There is significant production of drop-in diesel fuel, but it is primarily produced from soybean and other oils, which are not ideal feedstocks for future, large scale, sustainable fuel production. In order to establish large scale production capability (many gge/yr), it is necessary to develop cost-effective technologies for producing hydrocarbon, biofuels and very large, sustainable sources (many million metric tons/yr) of cellulosic feedstock. Neither of these requirements are currently close to being met. Development of the production technology will require large R&D and capital investments over long periods of time (> 10 years). This will result only if there is a national commitment to replace fossil-based fuels for vehicles with biofuels that is evident from regulations and fuel and price incentives that will remain in place for at least 10 years. Hopefully, this commitment will encourage the large oil companies to get re-involved with biofuel production and marketing.

Providing the large scale, sustainable feedstock supply will require state and national, coordinated programs that will organize both the production and gathering of the cellulosic feedstocks needed. These feedstocks must be low carbon intensity to satisfy the LCFS and RFS requirements, which will become more demanding in future years. Financial incentives for both capital investments in technology R&D and to feedstock suppliers will be necessary over many years. This will be possible only if the U.S. makes a firm commitment to replace a significant fraction of its fossil-based fuels with sustainable, biofuels.

## **5.6 Ways to increase customer demand for biofuels to enhance investments in infrastructure and vehicles that can use biofuels**

There are two ways to have high demand for biofuels. One way is to require, through regulation, blends of biofuels with fossil-based fuels, as in the case of gasoline and ethanol. The demand for ethanol would increase significantly if the blend fraction was increased from 10% to 15%. The second way is to have the price of the biofuel to the consumer be lower than the competitive fossil-based fuel. This is the approach taken in Brazil to promote the use of sugarcane based ethanol. Vehicles sold in Brazil are required to have bi-fuel capability. The biofuel is kept competitive by varying the tax on the different fuels as the price of oil changes.

As of July 2015, in most states in the US the per-gallon cost of E85 remains below the cost of gasoline (AFDC July 2015), and in some cases (e.g. California), it was substantially less. However, in many of these states, the cost per BTU may be close to par with ethanol blended gasoline. Presumably some consumers are aware that, on a per-gallon basis, the energy content of E85 is not as high as gasoline and consequently the fuel economy of their vehicle will be lower with E85. Experience has shown that most drivers of flex-fuel vehicles in the US use mostly gasoline, not E85.

Cost aside, consumers must be assured that the use of a biofuel will not damage the engine in their vehicle or negate the vehicle warranties. According to one workshop participant, some of the federal labeling of biofuels is more restrictive than warranted based on actual engine performance tests. Hence, the labeling should be re-evaluated so as to not to discourage consumers unnecessarily from using biofuels.

Some workshop participants stated that the California Air Resources Board (CARB) has not encouraged the use of biofuels as it has for other alternatives such as EVs and fuel cell vehicles. Large incentives to buyers of EVs have increased demand for those vehicles. On the other hand, biofuels not only lack those incentives, but the national blend wall has also limited the fuels' penetration into the market. One participant at the workshop suggested that setting minimum sales quotas for flex fuel vehicles sold by manufacturers would stimulate demand for alternative fuels. This would increase ethanol demand if the price of E85 on an energy basis was less than gasoline. CARB has set minimum sales quotas for EV and fuel cell vehicles which if implemented would increase the use of electricity and hydrogen for personal transportation.

## 6. References

- BioCycle (2015). California MSW Organics Digester Prepares to Launch, October 2015. Retrieved from <https://www.biocycle.net/2015/10/21/california-msw-organics-digester-prepares-to-launch/>.
- CALSTART. (2012). *Renewable Natural Gas (RNG): The Solution to a Major Transportation Challenge*. Retrieved from <https://www.americanbiogascouncil.org/pdf/EV-RNG-Facts-and-Case-Studies.pdf>
- Canabarro, N., Soares, J. F., Anchieta, C. G., Kelling, C. S., & Mazutti, M. A. (2013). Thermochemical processes for biofuels production from biomass. *Sustainable Chemical Processes*, 1(1), 22.
- CBC (2015). California Biomass Collaborative, Biomass Facilities Database. Retrieved from <http://biomass.ucdavis.edu/tools/california-biomass-facilities-reporting-system/>
- CEC (2015). Northstate Rendering Co Inc. Anaerobic Digestion of Rendering Waste to Produce CNG Vehicle Fuel. Retrieved from <http://www.energy.ca.gov/drive/projects/ARV-10-040.html>.
- CEC (2016). CleanWorld Sacramento Biodigester. Retrieved from <http://www.energy.ca.gov/tour/cleanworld/>.
- Dairy Cares (2016). Milestones in Sustainability. Retrieved from [http://dairycares.com/families/hilarides\\_and\\_borba](http://dairycares.com/families/hilarides_and_borba).
- Dayton, D. (2012). Conversion Technologies for Advanced Biofuels – Bio-Oil Production
- Elkind, E. (2015). *Challenges to In-State Biofuel Production*. Retrieved from <http://steps.ucdavis.edu/files/09-17-2015-Session-2-Ethan-Elkind.pdf>
- EPA (2015). US EPA Livestock Anaerobic Digester Database, AgSTAR Database of Livestock Digesters. Retrieved from <https://www.epa.gov/agstar/livestock-anaerobic-digester-database>
- Foster, A. (2015). *CEC & ITS-DAVIS WORKSHOP Session 2: Response & Group Discussion*. Retrieved from <http://steps.ucdavis.edu/files/09-17-2015-Session-2-Andy-Foster-Aemetis.pdf>
- Fulton, Lewis, Geoffrey M. Morrison, Nathan C. Parker, Julie Witcover, Daniel Sperling (2014) *NextSTEPS White Paper: Three Routes Forward for Biofuels – Incremental, Transitional, and Leapfrog*. Institute of Transportation Studies, University of California, Davis, Research Report UCD-ITS-RR-14-12. Retrieved from [http://www.its.ucdavis.edu/research/publications/publication-detail/?pub\\_id=2313](http://www.its.ucdavis.edu/research/publications/publication-detail/?pub_id=2313)
- Fulton, Lewis and Marshall Miller (2015) *STEPS-NCST White Paper: Strategies for Transitioning to Low-Carbon Emission Trucks in the United States*. Institute of Transportation Studies, University of California, Davis, Research Report UCD-ITS-RR-15-11. Retrieved from [http://www.its.ucdavis.edu/research/publications/publication-detail/?pub\\_id=2499](http://www.its.ucdavis.edu/research/publications/publication-detail/?pub_id=2499)

- Goodwin, D. (2015). *Accelerating the Market*. Retrieved from <http://steps.ucdavis.edu/files/09-17-2015-Session-3e-Dan-Goodwin-Oberon.pdf>
- Hill, S. (2015). U.S. biodiesel and renewable diesel imports decline 36% in 2014. Retrieved from <https://www.eia.gov/todayinenergy/detail.cfm?id=20452>
- ITS-Davis. (2015). *STEPS WORKSHOP: CRITICAL BARRIERS AND OPPORTUNITIES TO ACCELERATE BIOFUELS AND BIOMETHANE AS TRANSPORTATION FUELS IN CALIFORNIA*. Retrieved from Davis, CA, USA: <http://steps.ucdavis.edu/research/projects/initiating-transitions-2015-2030/steps-workshop-critical-barriers-and-opportunities-to-accelerate-biofuels-and-biomethane-as-transportation-fuels-in-california/>
- Kaffka, S. (2015). *Assessment of Critical Barriers and Opportunities to Accelerate Biofuels and Biomethane as Transportation Fuels in California*. Retrieved from [http://steps.ucdavis.edu/files/09-17-2015-Session-1-Kaffka\\_Assessment-of-Critical-Barriers-and-Opportunities-Sept-17-2015.pdf](http://steps.ucdavis.edu/files/09-17-2015-Session-1-Kaffka_Assessment-of-Critical-Barriers-and-Opportunities-Sept-17-2015.pdf)
- Krich, K., Augenstein, D., Batmale, J., Benemann, J., Rutledge, B., & Salour, D. (2005). *Biomethane from Dairy Waste, A Sourcebook for the Production and Use of Renewable Natural Gas in California* Retrieved from <https://www.americanbiogascouncil.org/pdf/biomethaneFromDairyWaste.pdf>
- Lewis, M. (2015). *Pearson Fuels*. Retrieved from <http://steps.ucdavis.edu/files/09-17-2015-Session-3f-Mike-Lewis-PearsonFuels.pdf>
- Mintz, M., Han, J., Wang, M., & Saricks, C. (2010). *Well-to-Wheels analysis of landfill gas-based pathways and their addition to the GREET model*. Retrieved from
- NaskeoEnvironnement. (2009). Biogas composition. Retrieved from [http://www.biogas-renewable-energy.info/biogas\\_composition.html](http://www.biogas-renewable-energy.info/biogas_composition.html)
- NPC. (2012). *Renewable Natural Gas for Transportation: An Overview of the Feedstock Capacity, Economics, and GHG Emission Reduction Benefits of RNG as a Low-Carbon Fuel*. Retrieved from [http://www.npc.org/FTF\\_Topic\\_papers/22-RNG.pdf](http://www.npc.org/FTF_Topic_papers/22-RNG.pdf)
- NREL. (2006). *Biodiesel and Other Renewable Diesel Fuels*. Retrieved from <http://www.nrel.gov/docs/fy07osti/40419.pdf>
- NREL. (2014). *Energy Analysis: Biogas Potential in the United States*. Retrieved from <http://www.nrel.gov/docs/fy14osti/60178.pdf>
- Olson, T. (2015). *California Mobile Source Incentive Programs*. Retrieved from <http://steps.ucdavis.edu/files/09-17-2015-Session-3c-Tim-Olson-CA-Energy-Commission.pdf>
- ORNL. (2011). *U.S. Billion-Ton Update: Biomass Supply for a Bioenergy and Bioproducts Industry*. Retrieved from [https://www1.eere.energy.gov/bioenergy/pdfs/billion\\_ton\\_update.pdf](https://www1.eere.energy.gov/bioenergy/pdfs/billion_ton_update.pdf)
- Prabhu, A. (2015). *Assessment of Critical Barriers and Opportunities to Accelerate Biofuels and Biomethane as Transportation Fuels in California Event* Retrieved from

<http://steps.ucdavis.edu/files/09-17-2015-Session-1-Anil-Prabhu-ARB.pdf>

Recycling Today (2015). Recycling Today, Zero Waste Energy and Blue Line Transfer awarded 2015 Innovator of the Year, September 2015. Retrieved from

<https://www.recyclingtoday.com/article/zero-waste-energy-blue-line-transfer-nwra-innovator/>.

Schlyer, L. (2015). *Use of Incentives to Commercialize Biofuels and Support Evolving Technologies*. Retrieved from <http://steps.ucdavis.edu/research/projects/initiating-transitions-2015-2030/steps-workshop-critical-barriers-and-opportunities-to-accelerate-biofuels-and-biomethane-as-transportation-fuels-in-california/>

Seiser, R., & Burke, A. (2015). *Prospects for the Development of Drop-in Liquid Biofuels (especially Gasoline) from Sustainable Feedstocks*. Retrieved from <http://steps.ucdavis.edu/files/09-17-2015-Session-1-Reinhard-Seiser-UC-San-Diego.pdf>

Teall, R. (2015). *Projection Factors for Biodiesel Production in CA*. Retrieved from <http://steps.ucdavis.edu/files/09-17-2015-Session-1-Russell-Teall-Biodico.pdf>

USDA. (2015). Biomass Crop Assistance Program for FSA. Retrieved from <http://www.fsa.usda.gov/FSA/webapp?area=home&subject=prod&topic=bcap>

Williams, E. (2015). *Critical Barriers Impeding RNG as a Transportation Fuel in California*. Retrieved from <http://steps.ucdavis.edu/files/09-17-2015-Session-2-Evan-Williams-Cambrian-Energy.pdf>

Wong, M. (2015). *CleanWorld's BioDigesters*. Retrieved from <http://steps.ucdavis.edu/files/09-17-2015-Session-3a-Michele-Wong-CleanWorld.pdf>

Yoon, J. J. (2011). *What's the Difference between Biodiesel and Renewable (Green) Diesel?* Retrieved from [http://advancedbiofuelsusa.info/wp-content/uploads/2011/03/11-0307-Biodiesel-vs-Renewable\\_Final-3\\_JJY-formatting-FINAL.pdf](http://advancedbiofuelsusa.info/wp-content/uploads/2011/03/11-0307-Biodiesel-vs-Renewable_Final-3_JJY-formatting-FINAL.pdf)



## Appendix I: Workshop Agenda and Attendees

### ***Assessment of Critical Barriers and Opportunities to Accelerate Biofuels and Biomethane as Transportation Fuels in California***

#### **Agenda & Attendees**

##### **September 17, 2015**

9:00 am - 5:00 pm

1605 Tilia Street, Davis, CA 95616

Institute of Transportation Studies, UC Davis-West Village

The California Energy Commission (CEC) and UC Davis Institute of Transportation Studies (ITS-Davis) will conduct joint workshops on September 17-18, 2015 to seek and discuss insights on the growth of biofuels and biomethane in California, progress achieved to date, critical barriers, and requirements needed to boost commercialization. The workshops will be held at the UC Davis on Sept. 17 and at the CEC on Sept. 18.

#### **UCD/CEC /workshop-Sept 17, 2015**

##### **Objective**

This workshop invites industry participants to estimate the growth of biofuels and biomethane in California, highlight critical barriers, and recommend actions to maximize and accelerate commercialization.

##### **Agenda**

8:45 9:00am	-	<b>Registration &amp; Coffee</b>
9:00 – 9:10		<b>Welcome and Introduction</b> ( <i>Janea Scott</i> , Commissioner, California Energy Commission; <i>Paul Gruber</i> , STEPS Executive Director, UC Davis) Welcome, project objectives, overview of the day

<p>9:05 10:35</p>	<p>– <b>Session 1: Biofuel and Biomethane Transportation Fuels - Setting the Stage</b></p> <p>Present information and elicit feedback on the amount of liquid biofuels and biomethane that are projected to be consumed and produced in California in five year increments for the short, mid and long term by 2030. Obtain insights about the existing and projected potential to help fulfill the AB 32 greenhouse emission reduction goals and the 2030 proposed 50% petroleum reduction goals.</p> <p>Presentations – 9:05 am to 9:50 am:</p> <ul style="list-style-type: none"> <li>· Russ Teall, President, California Biodiesel Alliance – [PG1] Prospects for Biodiesel</li> <li>· Jeff Reed[PG2] , Southern California Gas Company – Potential Development of Biomethane as a Transportation Fuel and Clean Up and Injection into Natural Gas Pipelines</li> <li>· Reinhard Seiser[PG3], UC San Diego – Prospects for the development of drop-in liquid biofuels (especially gasoline) from sustainable feedstocks</li> </ul> <p>Responses and Group Discussion – 9:50 am to 10:35 am:</p> <ul style="list-style-type: none"> <li>· Steve Kaffka[PG4], UC Davis and Biomass Collaborative</li> <li>· Anil Prabhu, California Air Resources Board</li> <li>· Tom Fulks[PG5], Diesel Technology Forum, MightyComm</li> <li>· Marshall Miller[PG6], UC Davis</li> </ul>
<p>10:35 12:30</p>	<p>– <b>Session 2: Critical Barriers Impeding the Development and Commercialization of Liquid Biofuels and Biomethane.</b></p> <p>Present information from industry surveys and meetings and obtain feedback to assess barriers that inhibit increasing the supply of various types of biofuels – technology, capital investment, achieving cost/price stability of the feedstock and resultant biofuels, government regulations, and customer acceptance.</p> <p>Presentations – 10:35 am to 11:15 am</p> <ul style="list-style-type: none"> <li>· Ethan Elkind[PG7], UC Berkeley and UCLA Law Schools – Boosting</li> </ul>

	<p>California Biofuels: Critical Barriers and Recommended Actions</p> <ul style="list-style-type: none"> <li>· Evan Williams[PG8], Executive Director, Renewable Natural Gas Coalition – Critical Barriers Impeding Biomethane as a Transportation Fuel</li> </ul> <p>Responses and Group Discussion – 11:15 am to 12:30 pm</p> <ul style="list-style-type: none"> <li>· Andy Foster, Aemetis, Inc.</li> <li>· Evan Edgar, Edgar and Associates[PG9]</li> </ul>
<p>12:30 – 1:30</p>	<p>Lunch</p>
<p>1:30 – 4:30</p>	<p><b>Session 3: Ideas and solutions to overcome the barriers for each of the biofuels.</b></p> <p>With the aid of a moderator/facilitator, the following topics will be discussed. In addition, stakeholders in the audience will contribute their ideas based on their experience in developing various biofuel technologies.</p> <p>Topics to be discussed by invited experts and commented on by workshop attendees:</p> <p>a. The necessity[PG10] to maintain continuity and certainty of regulations, incentives and other government activities. <i>Discussants: Michele Wong, CleanWorld; Joe Gershen, California Biodiesel Alliance</i></p> <p>b. Combinations [PG11] of incentives to maximize and accelerate commercialization and reflect evolving technology, project size and feedstock flexibility. <i>Discussants: Lyle Schlyer[PG12], Pixley Biogas; Dayne Delahoussaye, Neste Oil; Harry Simpson, Crimson Renewable Energy</i></p> <p>c. The support [PG13] and facilitation of the development of key business factors and models to increase industry capacity, price affordability for customers and attraction of private investment.</p>

	<p><i>Discussants: Diane Cummings, CA Infrastructure &amp; Economic Development Bank[PG14]; Tim Olson, CA Energy Commission</i></p> <p>d. Exploration[PG15] of methods to stabilize availability and acquisition of low carbon intensity feedstocks and longer term offtaker agreements.</p> <p><i>Discussants: Paul Relis, CR&amp;R Incorporated; Tom Koehler, Pacific Ethanol</i></p> <p>e. The stimulation [PG16] and acceleration of technology using cellulosic feedstocks and other advanced technologies.</p> <p><i>Discussants: Corinne Drennan, Pacific Northwest National Lab; Jim Boyd, Boyd Consulting; Dan Goodwin, Oberon[PG17]</i></p> <p>f. Approaches [PG18] to increase customer demand for biofuels and biomethane fuels and enhance investment in fueling systems, infrastructure, vehicle cost reductions and retail exposure to customers.</p> <p><i>Discussants: Tim Carmichael, CA NG Vehicle Coalition; Graham Noyes, Keyes Fox Weidman LLP; Mike Lewis, Pearson Fuels</i></p>
4:30 – 5:00	<b>Wrap-up and next steps</b>
5:00 – 7:00	Reception

## Registrants

First	Last	Job Title	Organization
Anil	Baral	Air Pollution Specialist	Air Resources Board
Beth	Bourne	Assistant Program Manager	ITS-Davis
Jim	Boyd	Owner	Boyd Consulting Group
Andy	Burke	STEPS Researcher	ITS-Davis
Tim	Carmichael	President	CA NGV Coalition
Elyse	Cheung-Sutton	Energy Analyst	CA Energy Commission
Michael	Coates	Principal	Mightycomm
Jon	Costantino	Senior Advisor	Manatt Phelps & Phillips

<b>First</b>	<b>Last</b>	<b>Job Title</b>	<b>Organization</b>
Diane	Cummings	Deputy Director Credit, Chief Credit Officer	CA Infrastructure & Economic Development Bank
Dayne	Delahoussaye	Legal Counsel and Regulatory Affairs Manager	Neste US Inc
Rhetta	DeMesa	Second Advisor	CA Energy Commission
Rosa	Dominguez-Faus	Postdoctoral fellow	ITS-UC Davis
Michael	Doyle	President	Agron Bioenergy
Corinne	Drennan	Biomass Laboratory Relationship Manager	Pacific Northwest National Laboratory
David	Dunn	Compliance and Renewables Manager	Idemitsu
Evan	Edgar	Principal Engineer	Edgar & Associates
Rob	Elam	CEO	Propel Fuels
Ethan	Elkind	Associate Director, Climate Change and Business Program	UC Berkeley / UCLA Law
Andy	Foster	EVP	Aemetis, Inc.
Jacques	Franco	Science & Policy Fellow	UC Davis Policy Institute
Tom	Fulks	West Coast Rep	Diesel Technology Forum
Lewis	Fulton	Co-director	ITS-Davis
Brian	Gannon	President	Biogas Energy
Shawn	Garvey	Chief Executive Officer	Grant Farm
Joe	Gershen	Vice Chairman	California Biodiesel Alliance
Robert	Gershen	Managing Director	Alternative Energy Managers
Daniel	Goodwin	Director of Business Development	Oberon Fuels
Paul	Gruber	STEPS Exec Dir	ITS-Davis
Roxyby	Hartley	Research and Development Director	Agron Bioenergy
Nathalie	Hoffman	CEO	California Renewable Energies
Andrew	Hom	Air Resources Engineer	California Energy Commission
Raphael	Isaac	Graduate Student Researcher	UC Davis
Amy	Jaffe	Executive Director, Energy & Sustainability	UC Davis
Claire	Jahns	Assistant Secretary for Natural Resources Climate Issues	California Natural Resources Agency
Elizabeth	John	Biofuels Supervisor	California Energy Commission
Evan	Johnson	Senior Environmental Scientist	CalRecycle
Stephen	Kaffka	Extension agronomist	UC Davis
Akasha Kaur	Khalsa, M.E.	Energy Analyst	California Energy Commission
Will	Kinney	Energy Specialist	California Energy Commission
Tom	Koehler	policy advisor	pacific ethanol
Mike	Lewis	Co-Founder	Pearson Fuels
Nick	Lumpkin	Director, Business Development	Clean Energy Renewables
Tryg	Lundquist	Associate Professor	Cal Poly, SLO

<b>First</b>	<b>Last</b>	<b>Job Title</b>	<b>Organization</b>
Ben	Machol	Manager, Clean Energy & Climate Change Office	U.S. EPA Region 9
Trina	Martynowicz	Renewable Natural Gas Coordinator	U.S. EPA Region 9
Steve	McCorkle	CEO	Ag Waste Solutions
Bruce	Melgar	president	UrbanX Renewables Group
Marshall	Miller	Senior Development Engineer	UC Davis
Lisa	Mortenson	CEO	Community Fuels
John	Naab	Western Regional Director	BioStar Renewables
Shelby	Neal	Director of State Governmental Affairs	National Biodiesel Board
Hieu	Nguyen	Energy Commission Specialist	California Energy Commission
Graham	Noyes	Attorney	Keyes Fox Wiedman LLP
Tim	Olson	Manager, Transportation Energy Office	California Energy Commission
Matthew	Ong	Energy Analyst	California Energy Commission
Michael	Paparian	Board Member	InterEnvironment Institute
Anil	Prabhu	Manager, Fuels Evaluation Section	Air Resources Board
Jeff	Reed	Director, Business Strategy and Advanced Technology	Southern California Gas Company
Paul	Relis	Senior Vice President	CR&R Incorporated
David	Rubenstein	President / CEO	California Ethanol & Power
Lyle	Schlyer	President	Pixley Biogas
Amy	Schwab	Sr Project Leader	National Renewable Energy Laboratory
Janea	Scott	Commissioner	CA Energy Commission
Reinhard	Seiser	Research Scientist	UC San Diego
Harry	Simpson	President/CEO	Crimson Renewable Energy
Courtney	Smith	Advisor	CEC
Doug	Smith	Assistant VP R&D/QA	Baker Commodities, Inc.
Russ	Teall	CEO	Biodico
Frederick	Tornatore	CTO	TSS Consultants
Stefan	Unnasch	Managing Director	Life Cycle Associates LLC
Samuel	Wade	Chief, Transportation Fuels Branch	Air Resources Board
Rob	White	Chief Strategist	Sierra Energy
Evan	Williams	President	Cambrian Energy
Clark	Williams	Environmental Program Manager	CalRecycle
Rob	Williams	Development Engineer	UC Davis
Michele	Wong	CEO	CleanWorld
Ruihong	Zhang	Professor	University of California, Davis
Hengbing	Zhao	Research Engineer	ITS-Davis

## Sustainable Transportation Energy Pathways Program (STEPS)

[www.steps.ucdavis.edu](http://www.steps.ucdavis.edu)

STEPS is the major multidisciplinary research consortium within the Institute of Transportation Studies at the University of California, Davis. The consortium is comprised of 40+ PhD-level faculty and researchers and graduate students from UC Davis, 25+ industry and governmental partners, and 20+ outside expert organizations. Our mission encompasses:

- Research: generate new insights and tools to understand the transitions to a sustainable transportation energy future for California, the US and the world,
- Outreach: disseminate valued knowledge and tools to industry, government, the environmental NGO community, and the general public to enhance societal, investment, and policy decision making,
- Education: train the next generation of transportation and energy leaders and experts.

The STEPS 2015-2018 program is generously supported by these sponsors:

- Auto: BMW, Cummins, Daimler, Ford, Fiat Chrysler, GM, Honda, Renault, Toyota, Volkswagen
- Energy: Aramco, Centre for High Technology (India), Chevron, Shell, San Diego Gas & Electric/SoCal Gas Co., Sinopec
- Government: California Air Resources Board, California Energy Commission, Caltrans, South Coast AQMD, U.S. DOE, U.S. DOT, U.S. EPA

Our program areas and overarching research questions are:

- **Initiating Transitions 2015-2030**: What is required for early alternative fuel/vehicle transitions to succeed?
- **The Future of the Fuels and the Oil & Gas Industry**: How will changing geopolitical landscapes and disruptive technology in the oil and gas and clean technology industry impact future business models and the competition of fuels?
- **Global Urban Sustainable Transport (GUSTO)**: How will a rapidly urbanizing world affect demand for transport and energy? How can we transition to sustainable transportation in a rapidly urbanizing world with ever-growing need for mobility?
- **Modeling Analysis, Verification, Regulatory and International Comparisons (MAVRIC)**: What do improved and cross-compared economic/environmental/ transportation/energy models tell us about the future of sustainable transportation?

[What is the Sustainable Transportation Energy Pathways program?](#)



[Why sponsors value the UC Davis STEPS program?](#)



**Comments and responses for this workshop, and STEPS program inquiries:**

Paul Gruber, STEPS Executive Director, [pwgruber@ucdavis.edu](mailto:pwgruber@ucdavis.edu), (530) 752-1934

## Appendix II: Participants' Comments

The following are comments submitted from participants in the Sept. 17 workshop hosted at UC Davis.

Websites suggested by one conference participant as helpful resources for those seeking financing options for small businesses in the state of CA:

- <http://businessportal.ca.gov/Business-Assistance/Financing-a-Business>
- <http://ibank.ca.gov/smallbusiness.htm>
- <http://ibank.ca.gov/resources.htm>
- <http://www.calrecycle.ca.gov/Funding/>
- <http://www.treasurer.ca.gov/cpcfca/calcap/index.asp>

Joe Gershen

***The necessity to maintain continuity and certainty of regulations, incentives and other government activities.***

Joe Gershen – Vice-chair California Biodiesel Alliance. 15 year California biodiesel industry veteran. Director of Marketing and Business Development – Altitude Fuel.

Everyone here today agrees that renewable biofuels offer a unique solution to lowering carbon content in transportation fuels in that they are typically blended with their fossil counterparts. And we all know that this sector of alternatives has done most of the heavy lifting in cutting carbon and displacing petroleum to date, and is expected to continue doing so for quite some time. Even if we could reduce our petroleum use to 50% by 2030, there probably is consensus that fossil fuels will still be with us for quite some time. So let's be pragmatic, roll up our sleeves, and help renewable fuels thrive.

The question is: what will it take to accelerate commercialization of biofuels? The answer is: CONSISTENCY. More specifically, there are 4 things that I believe directly address this question: Consistent regulations; programs with procedural certainty; fully integrated fuels infrastructure; and consistent sources of capital.

- #1 – Consistent, strong, reliable, and coordinated regulations are critical:
  - o Programs such as the Federal RFS and dollar tax credit, as well as California's LCFS need to remain in place – year over year – to allow alternatives to take hold, existing infrastructure to adapt, and businesses to adjust to new models and to become profitable.
  - o Sending a good and consistent message to the business and investment community that they can count on these programs to reliably remain in place will help the renewable biofuels sector thrive.
  - o Coordinating compliance between various regulatory agencies is crucial, but unfortunately is not the case today – air quality regulations, the burdensome CEQA process, building codes, program rules, reporting tools, and the fact that they can, and do, change quite frequently, and don't seem to be coordinated between regulatory agencies – often make compliance nearly impossible and will cause businesses to go elsewhere. And fines for non-compliance can make developing and



growing a business in California completely unrealistic. I am consistently told that companies want to comply with regulations but the state keeps moving the goal post.

§ One Possible Solution might be to establish a high-level biofuels task force to facilitate consistency among regulatory agencies and eliminate barriers between them. It would be imperative for industry to participate.

o A couple of problematic examples:

§ At the federal level, the RFS biomass-based diesel volume obligations have been erratic and not reflective of growth in these industries. Rather than setting obligations close to what the industry can actually produce, which would support its natural expansion, EPA has set the numbers significantly under actual production capacity resulting in slow-downs, lay-offs and plant closures.

§ And the dollar-per-gallon federal tax credit incentive for biodiesel has been in effect for over 10 years but every other year it lapses and then comes back retroactively for one lapsed year and forward for one year... although at the end of last year it unexpectedly lapsed again for the second year in a row, which wreaked havoc on the industry. Do you find yourself asking how an *incentive* can be *retroactive*? If you're confused then you're not alone. But I think everyone can understand that if the federal government had put this dollar credit into place in 2005 and businesses knew it would remain in effect for 10 years that would have sent an incredibly strong message to investors and the business community and would have helped create a thriving domestic industry. Instead it has had the opposite effect – creating volatility and uncertainty for 10 years – making the industry more reminiscent of a drug addict: ecstatic when the credit is in place but suffering toxic withdrawals when it lapses.

- #2 – Programs must have procedural certainty before they are implemented:

o Will they stand up to legal challenges?

o Are there pragmatic paths to success, rather than ideological wish lists?

o Have metrics been identified and implemented in advance to confirm success and will they be adhered to?

o Have scoring criteria such as carbon intensity been fully vetted before implementation so they don't have to be changed once the program is underway? This causes confusion and creates tremendous uncertainty in the market, ultimately affecting program credibility.

§ Businesses will invest in technologies partially based on the compliance message sent from government. If that message changes too often there is not time to realize a return on their investments, which is crucial to their survival and *continued* investments.

- #3 – Infrastructure must be developed to thoroughly blend with the existing transportation fuel industries:

o We are facing a poly-fuel future – there is no magic bullet that will simply replace fossil fuels – it really is an “all of the above” scenario.

o As mentioned earlier, biofuels have been providing the bulk of carbon reduction and petroleum displacement but are not expected to ever simply replace their fossil equivalents.

o Ethanol is blended with gasoline, biodiesel and renewable hydrocarbon diesel are blended with

#2 diesel, bio-jet is blended with jet fuel, and renewable natural gas (or bio-gas) will be injected and blended into the natural gas pipeline (although the standard for doing this has to be more realistic).

- o There are currently about 75 bulk fuel terminals and racks around California that distribute diesel fuel, but only about 10 have been retrofitted to blend biodiesel. In order to really move the needle on alternative diesel blending we need to commit to investing in storage and blending infrastructure at every rack and terminal in the state. In order to do this effectively and efficiently we must work within the existing petroleum infrastructure, which means the state must figure out how to partner with the petroleum industry to find solutions.

- #4 - There needs to be funding available on an annual and long-term basis.

- o Not enough money has gone into supporting biofuels in California.

§ ARFVTP is a great program but there is not enough funding allocated to biofuels, which have been providing the lion-share of program benefits, as well as generating most of the LCFS credits to date.

- o There needs to be an infusion of capital to support development of successful technology projects that we already know will lower carbon, displace petroleum and create jobs in disadvantaged communities.

§ A biofuels initiative, which would include an in-state production incentive and infrastructure expansion, has been proposed and widely supported. It would be highly successful – and funds would be allocated based on CI and CalEnviroScreen scoring.

- o New technology funding should be made available for projects that have potential to be transformative. But there also must be more diligent vetting of candidates so investments are responsibly made.

- o There needs to be delineation (or silos) between biofuels: bio-gas, diesel substitutes and gasoline substitutes. There also needs to be recognition of potentially disruptive biofuels technologies such as green crude made from waste and algal biomass that could be refined at existing petroleum refineries.

- o State and federal funding needs to be better integrated with private investment. There should be mechanisms in place to leverage public funding with private investments to create synergy between the two. This would apply to identifying opportunities, vetting technologies, and overseeing management to ensure effectiveness.

So, if we want to accelerate commercialization of biofuels in California we need to support development of technologies and infrastructure financially and through strong, reliable and coordinated regulations. This will in turn send a good and consistent message to investors, the business community, and our partners in the fuel industry.

Dan Goodwin

I have a few comments for your consideration:

1. Much was discussed about Government needing to support technology only when private funding is already in existence as a way of vetting the company's health and the validity of the

technology. In other words, it was intimated that if a company already had funding, either internally or through venture capital, set aside for a project, then that project had obviously been analyzed by experts and should be considered low risk by the CEC.

Would encourage the CEC to reject that line of thinking, or at least investigate the suggestion to separate funding opportunities into two categories – one, existing technologies (funded) that CEC supports and would like to encourage growth in technology or infrastructure; two, innovative, potentially ground-breaking research that may not have received venture funding due to it's level of risk and the new-ness of the technology.

2. Consider Government's role in supporting technology that is trying to cross the "Valley of Death." Capital funding is difficult to obtain in immature markets, especially in something as conservative as energy, and venture funding may not support valuable technology if it projects a long payback of 7-10 years. Arun Majumdar, former head of ARPA-E and former VP of Energy at Google said this recently: *"The role of the government is in the area of research. If we are to change course in our energy ecosystem—whether it is transportation fuel or electricity generation, and whether it's for energy security, the economy, or the environment—that shift has to rely on innovation. Innovation comes from long-term research in science and engineering, which has to come from the government. These days, we can't count on industry to support risky research ventures that might only produce revenue in the 15-20 year time frame.... There are multiple valleys of death. I'll discuss a few of them. The first valley of death is demonstrating proof of concept. If someone has an idea, and if they try it out in the lab and they can get it to work—that's proof of concept. Proof of concept is necessary but not sufficient. ARPA-E funded proof of concept research. Then comes proof of integrated systems. That's when you take your technology, which has demonstrated proof of concept, and put it into prototypes that enable people to see how it can serve a useful purpose. It's the next step beyond the "idea" stage, where you justify funding further research. After the proof of system has happened, then the industry needs to determine that they can develop a product or business around the technology. Then, you face the challenge of access to capital, and the various valleys of death that relate to achieving scale in manufacturing the product. In fact, there are other valleys of death as well. But in the early stages, that need for capital to build manufacturing capacity and scale is the biggest concern. And frankly, the venture capital market has withdrawn from energy in terms of new investments."*

3. Finally, it was mentioned during the discussions, but to reiterate the point. The State of CA should not be in the business of picking technology winners. The perception - and it may only be a perception, but we know how those become realities – is that the State has committed to electric vehicles and hydrogen at the expense of other technologies. It appears that tailpipe emissions have become the only priority by which a vehicle technology will be judged. The assembled biofuels experts at your panel were in violent agreement that the State should, instead of picking technologies, set broad carbon-based goals. Those goals should encompass the carbon consumed throughout the lifecycle – production, transportation, dispensing, and combustion (so-called well-to-wheel). If the goal is GHG reduction, in addition to SLCP and other air pollutants, then that should be the criteria used to judge applications and award support.

I hope these comments are useful. I do appreciate the chance to submit them.

Dan Goodwin  
Director of Business Development  
Oberon Fuels  
2445 Fifth Avenue, Suite 200

San Diego, CA 92101  
(619) 255-9361, x102 (office)  
(760) 410-8250 (mobile)  
dan@oberonfuels.com  
[www.oberonfuels.com](http://www.oberonfuels.com)

An issue that is a barrier to use of renewable diesel is the labelling requirement. The Federal Trade Commission regulates how fuels are labeled at the retail level. They have issued regulations requiring labels to identify blends of ethanol in gasoline and biodiesel in diesel fuel. Attached is a white paper with a better summary of the issue.

Renewable hydrocarbon diesel is a drop-in replacement for CARB diesel and can be used at any level. However, the federal labeling creates use limitations that are not warranted based on engine performance of fuel quality. As California's current scoping plan relies on increasing volumes of renewable diesel, we see the label issue as a barrier to greater distribution and use. In addition to the federal solutions discussed in the paper, we would look to California to implement its own California label to allow for greater penetration of renewable diesel blends into California's diesel stream.

Let me know if I can provide any additional information on this issue. Otherwise, I look forward to working with you and your team more.

Dayne

***Dayne Delahoussaye***

Legal Counsel and Regulatory Affairs Manager (USA & Canada)

**Neste US**  
1800 West Loop South, Suite 1700  
Houston, Texas 77027  
713.407.4415 – office  
281.788.1662 – cell  
Dayne.Delahoussaye@Neste.com  
[www.nesteoil.com](http://www.nesteoil.com)

**Chuck White, P.E.**  
**Government Affairs Consultant**  
**Waste Management**

In my view, the 10 principle challenges are:

1. Having to compete with the historic low price of fossil natural gas



2. The continuing uncertainty in the LCFS and RFS2 credit markets
3. The inability to secure long term (5+ years) contracts for the sale of these credits.
4. Difficult access to pipeline and interconnection costs – although the recent CPUC decision helps.
5. The CPUC standards for BTU content, Siloxane concentrations are prohibitive and ability to meet them is uncertain.
6. Failure to recognize and accept that landfills provide the largest immediately developable and most cost-effective source of methane. Existing landfills will keep generating methane for at least 30 years and it is unlikely that other sources will exceed LF production levels for at least 10-15 years.
7. Focus of air quality agencies (e.g., SCAQMD) on onsite engine emission limits rather than incentivize pipeline injection of biomethane to avoid emissions altogether.
8. Mixed messages from Natural Gas utilities and reluctance to help invest in biogas development projects.
9. Focus of policy makers on Methane as a SLCP that creates uncertainty over development.
10. Failure to recognize the fugitive renewable methane emissions is a relatively easy engineering problem that is solvable – but with added cost.

Please keep me in the loop for further discussions.

# Emerging Medium- and Heavy-Duty Vehicle Technologies: Market Barriers and Solutions

May 2016

A Workshop Report from the National Center  
for Sustainable Transportation

Andrew Burke (co-PI), University of California, Davis  
Amy Myers Jaffe (co-PI), University of California, Davis  
Lew Fulton, University of California, Davis  
Rosa Dominguez-Faus, University of California, Davis  
Marshall Miller, University of California, Davis  
Hengbing Zhao, University of California, Davis  
Guozhen Li, University of California, Davis  
Raphael Isaac, University of California, Davis  
Paul Gruber, University of California, Davis



**National Center  
for Sustainable  
Transportation**

**UCDAVIS**

**SUSTAINABLE TRANSPORTATION ENERGY PATHWAYS**

*of the Institute of Transportation Studies*

## **About the National Center for Sustainable Transportation**

The National Center for Sustainable Transportation is a consortium of leading universities committed to advancing an environmentally sustainable transportation system through cutting-edge research, direct policy engagement, and education of our future leaders. Consortium members include: University of California, Davis; University of California, Riverside; University of Southern California; California State University, Long Beach; Georgia Institute of Technology; and University of Vermont. More information can be found at: [ncst.ucdavis.edu](http://ncst.ucdavis.edu).

## **U.S. Department of Transportation (USDOT) Disclaimer**

The contents of this report reflect the views of the authors, who are responsible for the facts and the accuracy of the information presented herein. This document is disseminated under the sponsorship of the United States Department of Transportation's University Transportation Centers program, in the interest of information exchange. The U.S. Government assumes no liability for the contents or use thereof.

## **UC Davis Disclaimer**

The primary purpose of this report is to summarize insights from the December 3, 2015 workshop. Therefore, the views and recommendations expressed by workshop participants, and detailed in this report, do not necessarily reflect the views of the UC Davis research team.

## **California Energy Commission Disclaimer**

This report was prepared as the result of work sponsored by the California Energy Commission. It does not necessarily represent the views of the Energy Commission, its employees or the State of California. The Energy Commission, the State of California, its employees, contractors and subcontractors make no warrant, express or implied, and assume no legal liability for the information in this report; nor does any party represent that the uses of this information will not infringe upon privately owned rights. This report has not been approved or disapproved by the California Energy Commission nor has the California Energy Commission passed upon the accuracy or adequacy of the information in this report.

## **Acknowledgments**

This study was funded by a grant from the National Center for Sustainable Transportation (NCST), supported by USDOT through the University Transportation Centers program. The authors would like to thank the NCST and USDOT for their support of university-based research in transportation, and especially for the funding provided in support of this project.



# Emerging Medium- and Heavy-Duty Vehicle Technologies: Market Barriers and Solutions

Report for the California Energy Commission  
Workshop, “Assessment of Critical Barriers and  
Opportunities to Commercialize Medium- and Heavy-  
Duty Truck Technologies in California”  
– December 3, 2015 at UC Davis

---

A National Center for Sustainable Transportation Workshop Report

May 2016

Sustainable Transportation Energy Pathways Program, Institute of Transportation Studies,  
University of California, Davis

Andrew Burke (co-PI)

Amy Myers Jaffe (co-PI)

Lew Fulton,

Rosa Dominguez-Faus

Marshall Miller

Hengbing Zhao

Guozhen Li

Raphael Isaac

Paul Gruber



[page left intentionally blank]

## TABLE OF CONTENTS

EXECUTIVE SUMMARY .....	1
1. Purpose of the Workshop .....	3
2. Present Status of Alternative Vehicles .....	4
2.1 Markets and Companies for Alternative Trucks and Buses .....	4
2.2 Alternative Powertrains and Fuel Technologies Available.....	7
2.3 CEC Project Successes.....	23
2.4 References .....	30
3. Drivers for marketing of alternative trucks .....	31
3.1 EPA/NHTSA standards for fuel efficiency and CO2 emissions .....	31
3.2 Federal and California Engine Emission Standards .....	37
3.3 Federal and California incentives for trucks and buses .....	39
3.4 References .....	41
4. Barriers to Market Development .....	42
4.1 Structure of Manufacturing and Sales Markets for Trucks and Buses.....	42
4.2 Advanced Truck Costs and Economics.....	43
4.3 Decision-making processes for truck purchases .....	56
4.4 References .....	59
5. Solutions to promote market success for advanced (low GHG) trucks and buses.....	61
5.1 Government policies, incentives, and engine and vehicle emission standards.....	61
5.2 Role of fuel prices and alternative fuel support .....	63
Appendix I. Agenda and Attendees for Dec. 3 workshop at UC Davis .....	64
Appendix II. Questions for December 3, 2015 Workshop.....	69
Appendix III. Attendees of Dec. 3 workshop .....	70

## EXECUTIVE SUMMARY

The University of California, Davis and the California Energy Commission held a workshop, “Assessment of Critical Barriers and Opportunities to Commercialize Medium and Heavy-Duty Truck Technologies in California,” on December 3, 2015 at UC Davis. The workshop attracted over 100 stakeholders from technology developers, fleet operators, government agencies, private investors, universities, and non-profit organizations. This report summarizes the findings and recommendations of the workshop and related information concerning the status of medium duty (MD) and heavy duty (HD) on-road and off-road vehicle technologies, current and projected markets for MD/HD vehicles, and government policies and regulations that will influence the growth of MD/HD vehicle markets in the next 10-15 years.

The major drivers for the development of advanced MD/HD vehicles are the need to reduce their greenhouse gas emissions and air quality related pollutants. The need to reduce the reliance of freight transportation fossil fuels is also a driver. The emissions from engines used in MD/HD vehicles, primarily diesel engines, have been regulated for many years, with the most recent standards set for 2010. Due to the high prices of fuel encountered throughout much of the last decade, there has been a desire among MD/HD vehicle operators to increase the fuel economy of their vehicles; however, it was not until 2011 that EPA/NHTSA set the first fuel efficiency and CO<sub>2</sub> emission standards for engines and MD/HD vehicles (Phase 1) as an element of climate change policy. The engine standards also included those on NO<sub>x</sub>. The Phase 1 standards for 2014-2017 are in the process of being made more stringent for 2018-2027 (Phase 2). These regulations are the primary drivers for the development of technology improvements (i.e. both vehicle and powertrain technologies) to reduce the fuel consumption and greenhouse gas emissions from MD/HD trucks and buses. EPA/NHTSA studies indicate that the 2027 standards that reduce fuel consumption and CO<sub>2</sub> emission by about 25% from the 2010 baseline can be met without the need for implementing advanced vehicle electrification technologies, such as hybrids, batteries, and fuel cells. Significant improvements in engine efficiencies, however, will be needed.

Advanced powertrain technologies for hybrid-electric, all-electric, and fuel cell powered MD/HD vehicles are being developed worldwide by large OEMs and small start-up companies. On-road demonstrations of all of these advanced technologies are underway for many types of trucks. These technologies and their costs relative to conventional engine/transmission technology are reviewed in this report. At the present time, the primary market for these advanced technologies is the transit bus market, where they are being sold in relatively large numbers worldwide. In particular, battery-powered buses are sold in China by the thousands per year by multiple bus suppliers and, in the United States, hybrid-electric buses represent about 30% of the new transit bus sales. Fuel cell-powered buses are also being demonstrated worldwide, though in small numbers. The costs of the advanced buses are much greater than the conventional buses in both the United States and China, and their sales are supported by government subsidies.

The continuing experiences with advanced buses indicate that the associated technologies are well-developed. As has been found with traction batteries used in vehicles of all types and sizes, it is expected that the cost of advanced vehicles and the components used in them will decrease markedly as the volume of production increases in the coming years. As discussed in the report, during this period of large cost reduction and technology improvements, the primary drivers of sales of advanced technology vehicles are government regulations and subsidies. Experience has shown numerous times that when subsidies are phased out, sales of the advanced technologies decrease very quickly unless these technologies are mandated by regulations. In this case, it can be expected that the Phase 1 and 2 EPA/NHTSA standards for all types of MD/HD trucks will be met without subsidies because of the regulations that are currently in place. Markets for MD/HD vehicles meeting regulations more stringent than Phase 2 will require significant reductions in the costs of advanced vehicles and technologies and/or more stringent regulations in the future.

## 1. Purpose of the Workshop

Both the United States and California have made commitments to achieve an 80% reduction in energy-related greenhouse gases (GHGs) from 1990 levels by 2050 in order to help stabilize atmospheric concentrations of GHGs. According to various analyses focused on achieving these GHG targets, transportation must play a large role in GHG mitigation through vehicle efficiency, advanced vehicle technologies, low-carbon fuel switching, and travel demand management. Low-carbon fuels such as hydrogen, natural gas, biofuels, and electricity are necessary elements of a sustainable transportation portfolio in most world regions, including California. In very optimistic low-carbon fuel mix scenarios developed by UC Davis, the California Air Resources Board, and others, use of these alternative fuels would need to grow considerably and, by 2050, be displacing on-road petroleum-based transportation fuels by approximately 80-90% in order for GHG goals to be met by 2050 (Yang, 2015). In 2015, Governor Brown of California set a target to reduce on-road petroleum usage in 2030 by up to 50%.

The Sustainable Transportation Energy Pathways (STEPS) team at the UC Davis Institute of Transportation Studies (ITS-Davis) and the California Energy Commission (CEC) conducted joint workshops on December 2 and 3, 2015 to seek and discuss insights on the growth of medium- and heavy-duty truck technology development and implementation in California, including progress achieved to date, critical barriers, and steps/policies needed to boost commercialization. The workshops were held at the CEC on December 2, 2015 and at UC Davis on December 3, 2015.

This document summarizes recent UC Davis research on the status of medium- and heavy-duty truck technologies and their commercialization and discusses insights from the December 3 workshop at UC Davis, *“Assessment of Critical Barriers and Opportunities to Commercialize Medium- and Heavy-Duty Truck Technologies in California,”* in which over 100 stakeholders from industry, government and academia discussed the status of MD/HD technologies in California, highlighted critical barriers to commercialization, and recommended actions to maximize and accelerate commercialization. (Appendices I, II, and III list the agenda, key questions, and stakeholders who attended this workshop. The STEPS website page (<http://steps.ucdavis.edu/research/projects/initiating-transitions-2015-2030/steps-workshop-commercialization-of-md-and-hd-truck-technologies-in-ca/>) for this event lists these items as well as presentations.)

The December 3 workshop was the second in a series of three workshops, funded by the CEC and through the National Center for Sustainable Transportation, aimed at assessing critical barriers to commercialization for alternative fuel and vehicles technologies in California. The objective of this CEC-funded program is to “identify environmentally and economically promising alternative fuel and vehicle emerging technologies, and to identify and evaluate the critical business and policy barriers blocking their widespread adoption in the state and actionable solutions to overcome those barriers. Through this subtask we seek to analyze the broad range of commercial barriers and identify strategies to increase the adoption and rapid scale-up of emerging technologies, fuels and fueling infrastructure that will help the state

achieve its AB118 targets and goals for air quality and greenhouse gas emissions” (excerpted from UC Davis Statement of Work, CEC Agreement ARV-13-020).

The third workshop in this series is on April 26, 2016 at UC Davis, and focuses on commercialization and deployment of plug-in electric vehicle infrastructure in California for light duty vehicles, freight, and transit. This coincides with an April 25 merit review public workshop conducted at the CEC on the same topic.

## **2. Present Status of Alternative Vehicles**

### **2.1 Markets and Companies for Alternative Trucks and Buses**

Truck manufacturers are developing new powertrain technologies for trucks across a wide variety of applications. Some of these technologies are being commercialized, but the majority involve demonstrations of small numbers of vehicles. Present demonstrations are often in niche markets where technology is matched to the application. Markets include:

- Heavy-duty drayage (port)
- Heavy-duty long-haul
- Heavy-duty day cab
- Heavy-duty refuse
- Work-site utility
- Medium-duty delivery
- Transit and school buses

The new technologies include:

- Conventional vehicle efficiency improvements
- Low NOX natural gas engines
- Hybrid-electric powertrains
- Battery-electric powertrains
- Dimethyl Ether fuel
- Fuel cell and hydrogen

Of these technologies, the only ones which have been commercialized are natural gas-fueled engine and hybrid-electric trucks and buses. Many transit agencies operate a significant number of natural gas buses, and hybrid-electric buses are widely in use as well. The medium-duty delivery truck market includes a significant number of natural gas fueled and hybrid-electric vehicles. More recently, heavy-duty, long-haul natural gas trucks have been marketed.

A few companies are beginning to offer battery-powered electric trucks and buses for sale, and fuel cell/hydrogen buses remain in the demonstration stage. Major truck OEMs are presently marketing specialty trucks with hybrid-electric powertrains (e.g. Freightliner in Business Class M2 Hybrid trucks), but are waiting to see how the market for battery-electric and fuel cell trucks will develop. In these markets, small innovative companies are leading the way in

demonstrations and sales. A specific market application for battery-electric, plug-in hybrid, and fuel cell trucks is worksite trucks, several of which are described below.

### Battery-powered Electric Buses

The sales of battery-powered electric transit buses are booming worldwide, and these buses will demonstrate the electric drive technologies needed to commercialize medium- and heavy-duty trucks. Proterra, New Flyer, BYD, and others have produced buses that are currently operated by transit agencies. Most of these buses use lithium batteries, store 200-300 kWh of energy, and have ranges up to 200 miles.

### Fuel cell/Hydrogen Buses

Fuel cell/hydrogen buses (including powertrains that are sometimes hybridized with a battery) are operating in transit fleets around the world. Seven transit agencies have operated fuel cell buses in the US and Canada. A total of 42 buses have been operated, with 19 currently active. Additional fuel cell buses are operating in Europe and Asia. Table 1 shows the transit agencies, the bus providers, and the fuel cell companies that have demonstrated fuel cell buses.[1] These buses are expensive, but they demonstrate the operation of fuel cells of the size (100-200 kW) needed in heavy duty trucks.

**Table 1. Transit agency fuel cell bus demonstrations**

(Source: L. Eudy, M. Post, and C. Gikakis, *Fuel Cell Buses in U.S. Transit Fleets: Current Status 2014*, NREL Technical Report, NREL/TP-5400-62683, December 2014.)

Transit Agency	Bus Provider	Fuel Cell Company
AC Transit	Van Hool	US Hybrid
Sunline	New Flyer and El Dorado	Ballard
BC Transit	New Flyer	Ballard
Birmingham	EVAmerica	Ballard
Flint MTA	Van Hool	US Hybrid
University of Delaware	Ebus	Ballard
Greater New Haven Transit District	Ebus	Ballard

### Medium- and Heavy-Duty Trucks

There are a number of applications in the medium- and heavy-duty class, where companies are marketing hybrid-electric and hybrid-hydraulic-powered trucks. Some of these products involve retrofitting existing trucks, but most take existing truck platforms and install the advanced hybrid drivelines. Medium-duty markets include cargo vans, box trucks, shuttle buses, cab over

engine trucks, and delivery trucks. Heavy-duty applications include yard tractors, flatbed trucks, refuse collection trucks, and transit buses. Table 2, below, shows the companies that have offered products in these markets.

**Table 2. Companies offering advanced truck products**

(Source: UC Davis, STEPS)

Company	Products
Freightliner/Eaton	Box and work site trucks
Zenith	Cargo vans
TransPower	Yard tractors, day cab trucks (NOTE: both battery-electric and fuel cell)
BYD	Box trucks
Phoenix	Shuttle buses, flatbed trucks
Smith	School buses, delivery trucks
Orange EV	Terminal trucks
Adomani	School buses, cab over engine trucks, shuttle buses, delivery trucks
Workhorse	Delivery trucks
Motiv	Refuse trucks, shuttle buses, delivery trucks
Hino	Hybrid cab over engine trucks
XL hybrids	Hybrid Shuttle and delivery trucks
Efficient Drivetrain	Hybrid utility and box trucks
Effenco	Stop-start hybrids, terminal tractor hybrids

### Worksite Utility Trucks

Utility trucks drive to worksites, where they use their diesel engines to power generators to supply electrical power at the site. Some companies have installed large battery systems on these trucks to supply the worksite power, allowing the diesel engines to shut off while at work sites. After returning to the “home” parking lot, the batteries can be plugged in and charged. These trucks offer quiet worksite operation and potential cost savings. Companies offering plug-in worksite utility trucks include Odyne, Altec, Phoenix, and Terex.



## **2.2 Alternative Powertrains and Fuel Technologies Available**

### **2.2.1 Alternative Powertrains Under Development**

Electrified powertrain systems using various configurations – from hybrid and plug-in hybrid technology to all- electric powertrains- have been employed in passenger cars. These systems improve fuel economy, lower emissions, enhance performance, and recover energy during braking. Compared to passenger vehicles (light-duty, or LD), development of electric and hybrid powertrains for medium-duty (MD) and heavy-duty (HD) trucks has been much more limited due to their low production volumes and wide variability in use cycles. Electric and hybrid-electric powertrains for MD and HD trucks and buses are similar to those used in passenger cars, but require larger components with higher power levels to handle the larger vehicle weights and unique use and driving cycles of these vehicles.

Electric and hybrid MD and HD vehicles are currently being manufactured and demonstrated by most of the major U.S. bus and truck manufacturers, such as Daimler, New Flyer, North American Bus Industries (NABI), Gillig, IC Corporation, and Nova Bus, Freightliner, Hino, Kenworth, Mack, Volvo, Navistar, PACCAR, Peterbilt, etc. Most of these companies use hybrid electric drivetrains from BAE, Allison, Eaton, Azure Dynamics, Enova, Odyne, Nino, Parker Hannifin, Volvo, etc. Other manufacturers have focused on all-electric vehicles or specialized hybrid powertrains to meet specific requirements. These manufacturers provide diverse powertrain configurations for different applications.

Electric and hybrid powertrains can be classified into all-electric, hybrid-electric (series, parallel, and series-parallel), and hydraulic-hybrid. Each powertrain type is discussed in one of the following sections:

#### **2.2.1.1 All-Electric Drivetrains**

An all-electric vehicle is a vehicle that is powered entirely on electrical energy. Its powertrain is relatively simple, having only an electric motor and electronics and a large battery or fuel cell that converts hydrogen to electricity. A basic all-electric powertrain is shown in Figure 1. There are many variations on the detailed design, based on the size, number and position of traction motors, and the use of transmissions.

Currently, in the United States, there are three companies that offer as products battery-powered all-electric transit buses: Proterra, BYD, and New Flyer. Nova is currently demonstrating a prototype. The Proterra bus utilizes a 220 kilowatt permanent magnet drive motor and a two-speed automatic transmission. Since electric motors can generate full torque at very low speeds, a multi-speed transmission is often used to increase the top speed of the vehicle without overspeeding the motor. A two-speed transmission can also increase acceleration performance of the vehicle and contribute to simplification of the motor cooling system. BYD utilizes two 90-kW wheel-hub motors on each axle for their 40-ft electric buses (Figure 2).

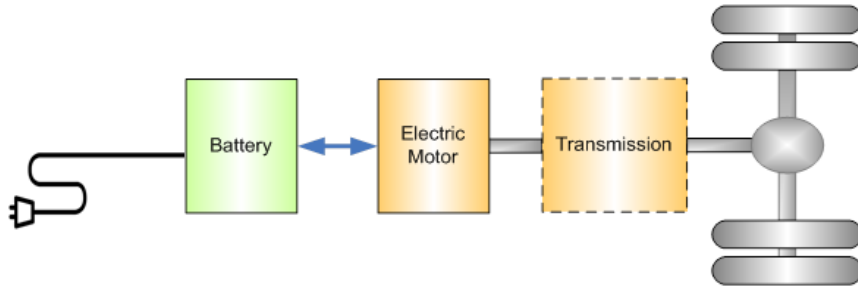

**Figure 1. All-Electric Powertrain**

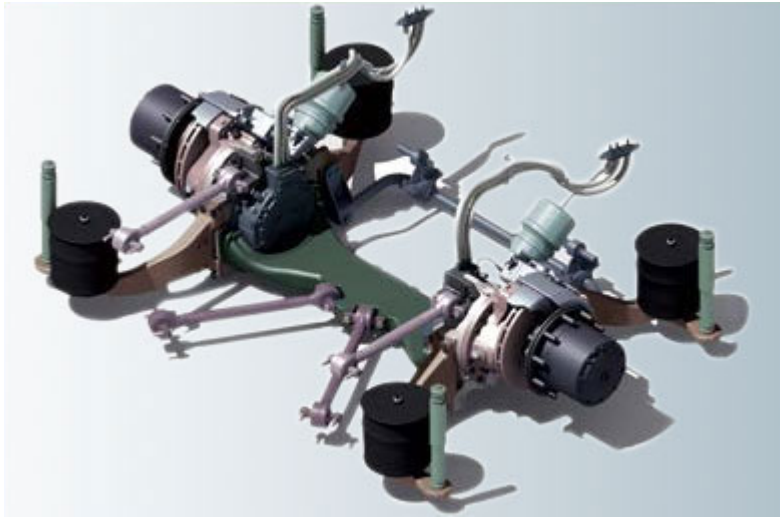

**Figure 2. BYD wheel-hub motor drive system**

Pure battery-electric HD trucks with a hauling capacity of up to 80,000 pounds have been developed and demonstrated by several smaller electric powertrain manufacturers such as TransPower, Balqon, and Orange EV. These all-electric trucks, with a range of about 120 miles, are targeting the short-haul drayage market.

Catenary systems to access an overhead power source are being developed for heavy-duty electric trucks to extend their range for long-haul trucking. An example is the Siemens eHighway (Figure 3), which is demonstrating the electrification of selected road lanes via a catenary system, similar to how modern day trolleys or streetcars are powered on city streets, while still offering the same flexibility as diesel trucks. Electrified catenary systems may offer an economically attractive and environmentally friendly solution to transport goods on highly frequented routes near ocean ports. Pantograph systems are also being developed on several hybrid truck platforms, including:

1. Volvo Diesel Hybrid

- Major OEM partnering through existing DOE diesel hybrid development project

- All-electric range capability (off catenary)
2. TransPower CNG Hybrid
    - Major OEM chassis - local integrators' technology
  3. TransPower Battery-electric
    - Leveraging local integrator's current technology development
  4. BAE Kenworth CNG Hybrid
    - Leveraging DOE project with catenary accessible hybrid



**Figure 3. Siemens eHighway**

### **Summary of present status**

At the present time, medium- and heavy-duty on-road BEVs in California are predominantly trucks and buses that operate on urban or suburban routes, and which have a high frequency of stops and starts, high idle times, lower average speeds, and daily ranges of generally 100 miles or less. Battery-electric buses are making inroads into transit fleets and represent the largest number of medium- and heavy-duty BEVs currently in operation. There are over 2,500 electric buses globally. Transit buses from three manufacturers are available, commercially, in the United States, employing different battery charging strategies - quick in-route charging (Proterra) and slow overnight charging. Most medium- and heavy-duty BEV truck deployments have been in the urban vocational work truck category, focusing on urban transit buses and intracity delivery. A summary of BEV deployments and technology readiness level for several of the vehicle categories that have seen deployment of BEVs is in Figure 4 [1].

Vehicle Type	Technology Readiness	Number in Service	Notes
Transit Bus	Commercially Available	~40 in California > 2,500 worldwide	3 models are commercially available in US
School Bus	Limited Commercial Availability	4 in California	3 new buses ordered in SCAQMD 6 repowers underway with V2G
Medium-Duty (8,501 to 14,000 lbs. GVWR)	Limited Commercial Availability	300+	Focused on delivery service
Heavy-Duty (> 14,000 lbs. GVWR )	Demonstration Phase	2 Drayage 1 Refuse	13 Class-8 Trucks under construction

**Figure 4. Summary of BEV Deployments and Technology Readiness Levels (data courtesy of CARB)**

### 2.2.1.2 Hybrid-Electric Powertrains

Hybrid-electric powertrain systems integrate conventional powertrain components, such as internal combustion engines and transmissions with electric components (i.e. electric motor and electrical energy storage, such as batteries and supercapacitors). A hybrid-electric vehicle has two power sources, usually an internal combustion engine and an electric motor and battery. Based on the power flow paths, series, parallel, and series-parallel (or power split) hybrid powertrains are in use in MD and HD trucks and buses.

#### Series Hybrid Electric Vehicles

A series hybrid is essentially an all-electric vehicle with on-board generation of electricity, as shown in Figures 3 and 4. This setup provides for range extension. The onboard electricity generation can be done using either a combustion engine or a microturbine driving an electric generator or a fuel cell stack. The generator both charges the main storage battery and provides electricity directly to the electric motor that powers the vehicle. Depending on the state of charge of the battery and power demand, series hybrids can run in the all-electric mode or series hybrid mode. Series hybrid-electric drivetrains are usually used in vehicles, such as transit buses, which operate at low average speed and have frequent stop-and-go driving cycles. Most series hybrids use an ICE such as the one shown in Figure 5. New Flyer hybrid buses use the ISE Corporation’s ThunderVolt series hybrid drive propulsion system with a Ford

6.8 L Triton V-10 gasoline engine [3]. Daimler utilizes the BAE Systems series hybrid system in their Orion transit buses. Several thousand Daimler Orion hybrid buses have been sold in North America. Wrightspeed developed an 80 kW Fulcrum multi-fuel microturbine-generator (genset) range extender (Figure 6) for MD and HD electric powertrains to recharge the battery pack.

It is also possible to design a series hybrid using a hydrogen fuel cell instead of an ICE, creating a fuel cell hybrid bus, as shown in Figure 7. The BC Transit fuel cell buses built by New Flyer are series hybrids, and include a 150 kW Ballard fuel cell and a 47 kW lithium phosphate battery. Daimler Orion VII compound fuel cell hybrid buses demonstrated in San Francisco use a BAE HybriDrive series propulsion design, combining a diesel hybrid propulsion system with a fuel cell to meet the demands of urban transit operation, as shown in Figure 6. The fuel cell can be used to provide the accessory loads, such as heating and air conditioning, when the vehicle is stopped. The ISE Corporation's ThunderVolt series hybrid drive propulsion system (Figure 9) and the BAE Systems HybriDrive series hybrid system (Figure 10) are series hybrid powertrain configurations that are utilized by major transit bus manufacturers in the U.S.

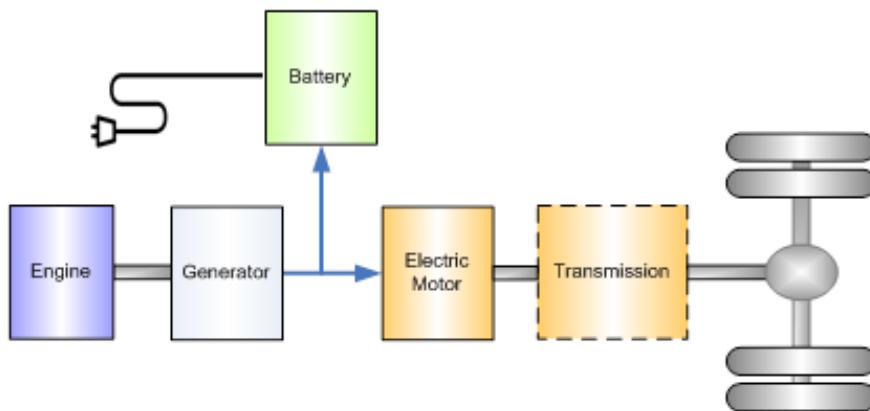

**Figure 5. Plug-in Series Hybrid Powertrain with an ICE Engine**

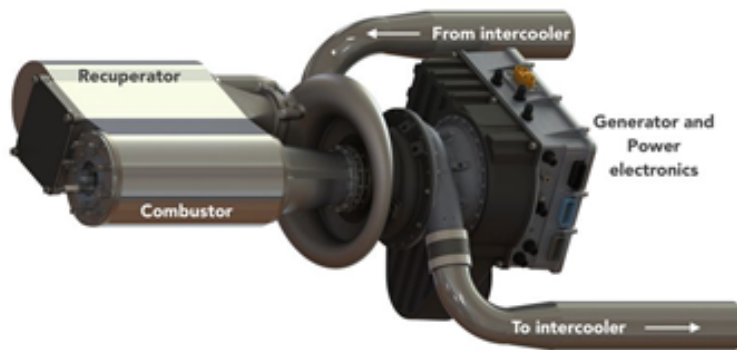

**Figure 6. An 80 kW Fulcrum microturbine generator**

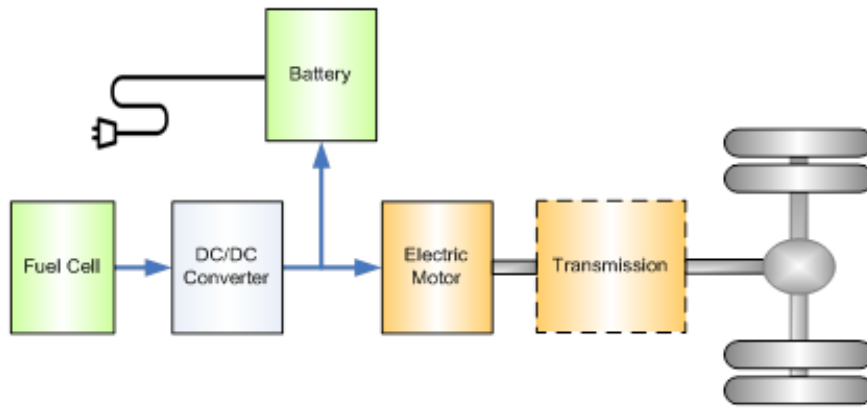

Figure 7. Plug-in Series Hybrid Powertrain with a Fuel Cell

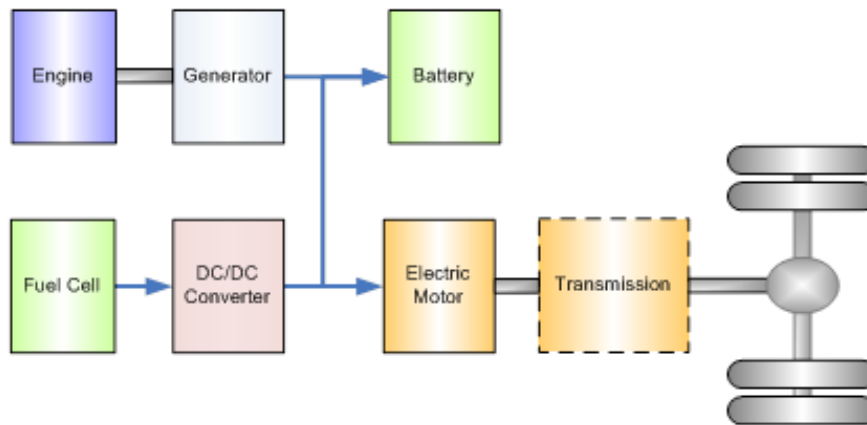

Figure 8. Series Hybrid Powertrain with a Fuel Cell and an Engine

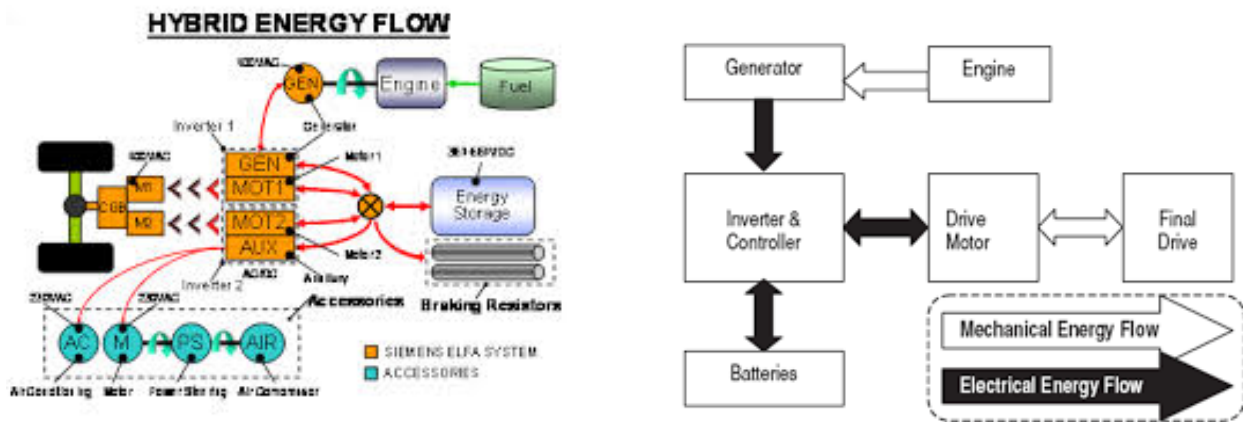
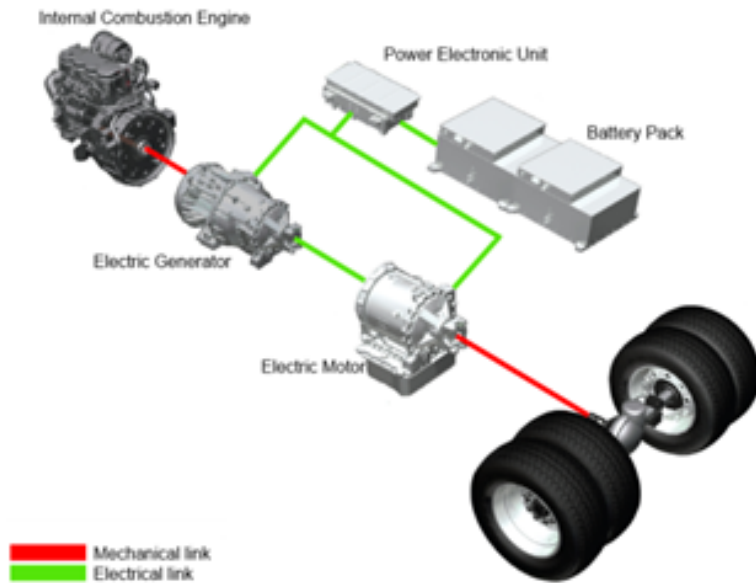

Figure 9. ISE Series Hybrid Powertrain



**Figure 10 BAE System Series Hybridrive**

### **Parallel Electric Hybrid**

In a parallel hybrid powertrain, the engine and the electric motor can provide torque to the wheels either alone or in combination (Figure 11). There is usually a clutch to decouple the engine from the drivetrain, which allows the vehicle to operate in an all-electric mode at low speeds. Based on the size of the motor, parallel hybrids are termed mild or full hybrid. If the electric motor is large enough that the vehicle can be operated on electric power, alone, during most operating conditions, it is termed a “full hybrid”. For a “mild hybrid”, the electric motor is much lower power than the engine and the vehicle can only run on the electric motor alone at low speed and low power. Since both the engine and the motor can be used to directly propel the vehicle, the average efficiency of a parallel hybrid is higher than a series configuration over a wide range of driving/duty cycles.

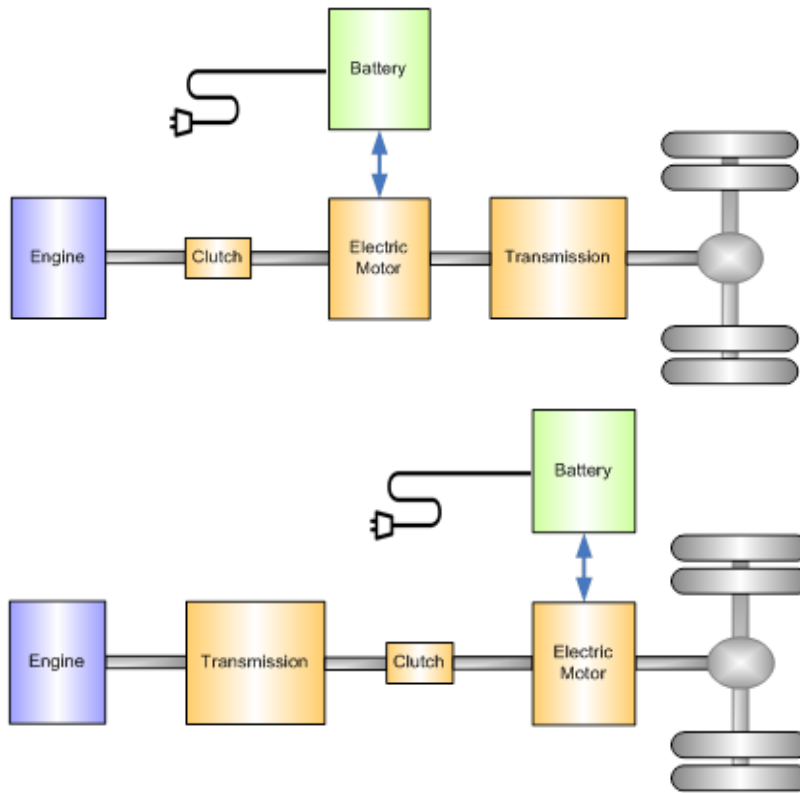

**Figure 11. Parallel Hybrids with Pre- and Post-Transmission Configuration**

Parallel hybrid configurations are often used in MD and HD vehicle applications. BAE HybriDrive Parallel System, shown in Figure 12, is designed to address the needs of vehicles with driving/duty cycles that require high vehicle speeds and less frequent stops. Daimler uses the Eaton parallel hybrid drive system in their Freightliner hybrid trucks and school buses. The Eaton electric hybrid power system (Figure 13) uses a parallel configuration that maintains the vehicle's conventional drivetrain layout while using patented controls to blend engine torque with electric torque to power the vehicle. The system can provide engine-off power take off and work site capability for those needing hydraulic operations and an auxiliary electric power source from the vehicle. The parallel hybrid is well-suited to improve fuel economy of higher speed vocational vehicles.



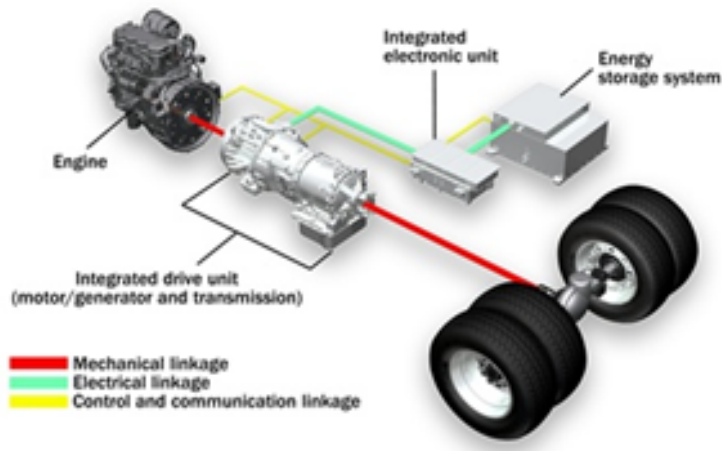

**Figure 12. BAE HybriDrive Parallel System**

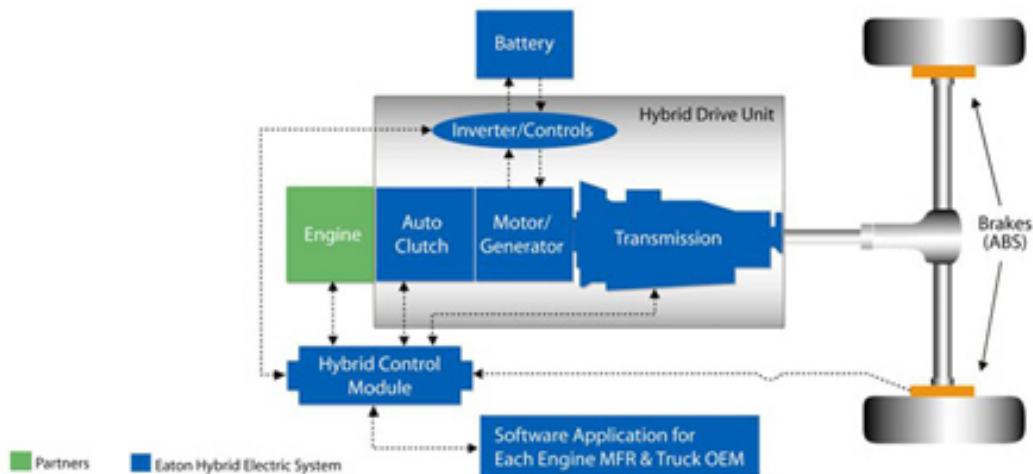
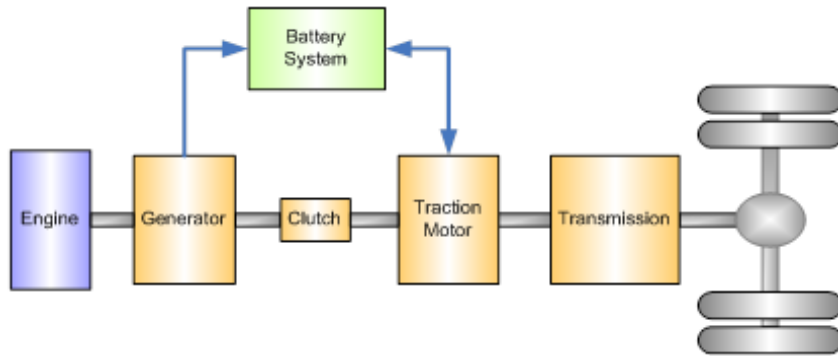

**Figure 13. Eaton Parallel Hybrid System**

### Series-Parallel Hybrid (Power Split)

The series-parallel hybrid configurations combine the characteristics of both the series and parallel hybrid designs to achieve high drivetrain efficiency over a wide range of driving/ duty cycles. Through the use of mechanical clutches or a planetary gear set, the engine can both drive the wheels directly at higher speeds and be effectively disconnected at lower speeds. In other words, at lower speeds, the series-parallel hybrid operates as a series-hybrid vehicle, and electricity is used to propel the vehicle, while at high speeds, where the energy conversions from mechanical to electrical and back to mechanical are less efficient, engine power can be used directly to propel the vehicle. Thus the engine can operate within its optimum operating range (i.e. high efficiency) most of the time. The series-parallel hybrid is thereby well-suited for,

both, city, stop-and-go, driving, and high-speed highway driving. Figure 14 shows a simple series-parallel powertrain configuration with a clutch.



**Figure 14. Series-Parallel Powertrain Configuration**

Planetary gear sets are used for controlling power flows without torque interruption from the engine or electric motor to the wheels. Series-parallel hybrids using planetary gear sets are also called power split hybrids. Power split hybrid powertrain configurations using a single or multiple planetary gears have been widely used in passenger vehicles such as the Toyota Prius and Chevy Volt. Power split hybrids can take advantages of both series and parallel configurations to provide an electrically variable transmission (EVT or eCVT) function. Single or multiple planetary gear sets carry out input split (ICE side), output split (output shaft side), or compound split, and produce various power-split configurations by adding multiple clutches. The power split configuration gives the flexibility to size engines, motors, and generators for different duty cycles and vehicle weights, and achieves the best fuel economy as well.

Figure 15 shows various power split configurations/transmissions. For example, a 2-mode EVT with both an input-split mode and a compound-split mode fundamentally lowered the requirement for motor power, allowing the EVT to be selected as a sound basis for GM's heavy-duty bus hybrids. In a 2-mode hybrid transmission configuration, a combination of two power-split modes reduces the amount of mechanical power that must be converted to electricity for continuously variable transmission operation. Four fixed gear ratios further improve power transmission capacity and efficiency for especially demanding maneuvers such as full acceleration, hill climbing, and towing. 2-mode hybrid transmission configuration is best suited to full-size SUVs and other personal trucks that require towing, especially for high continuous engine power [4].

The two power split configurations/transmissions based on the 2-mode split hybrid design are the Allison H 40 EP and the somewhat heavier-duty H 50 EP, which handles up to 330 horsepower from a matching Cummins diesel engine. It contains three planetary gear sets and two clutches, which allows for two different modes of operation — an EVT mode used at lower (city) speeds and an alternate EVT mode used at higher (highway) speeds, for better efficiency.

Allison Hybrid EP transmission has been the largest selling hybrid transit bus transmission and is one of the two major hybrid bus systems sold today.

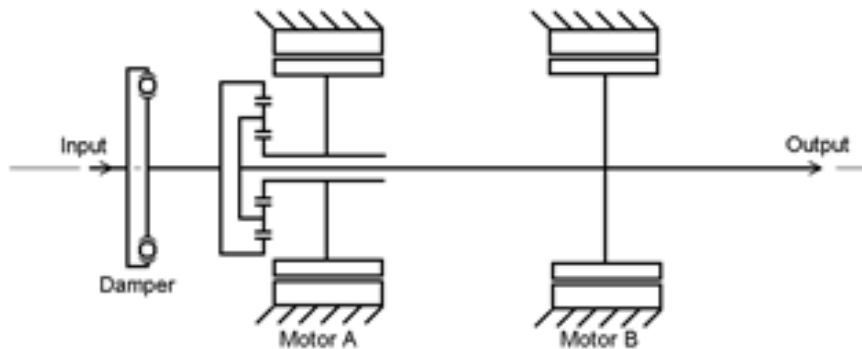

1-Mode EVT Arrangement (Input-Split EVT)

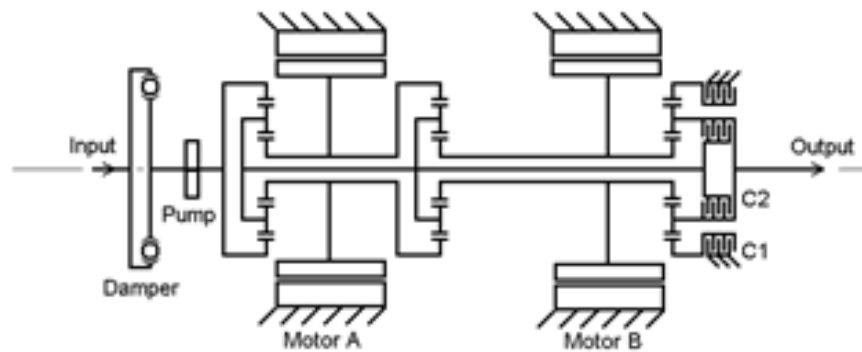

2-Mode EVT Arrangement

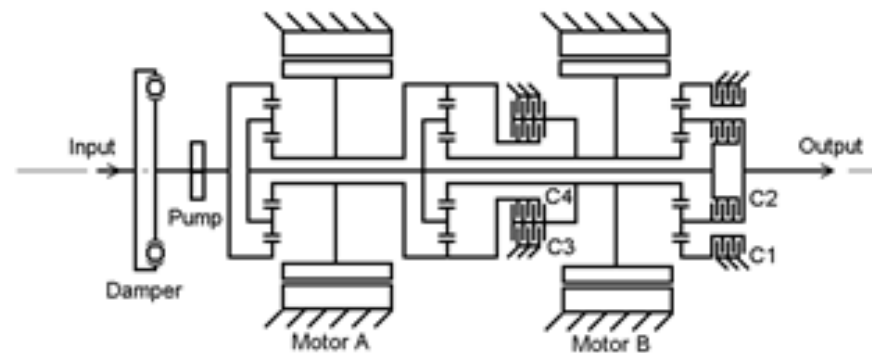

2-Mode Hybrid Configuration

**Figure 15. Power Split Hybrid Powertrain Arrangement [4]**

### 2.2.1.3 Hydraulic Hybrid Drivetrains

An electric hybrid vehicle recaptures the vehicle's kinetic energy during deceleration and stores it, in the form of electricity, in electric energy storage media, such as batteries or supercapacitors. In a hydraulic hybrid vehicle (HHV), a pressurized hydraulic fluid storage system is used to capture and deploy energy. Hydraulic pumps and accumulators store braking energy and, upon acceleration, use the stored energy to provide torque to power the wheels. Hydraulic hybrids are a viable alternative that are coming to market for certain types of trucks with driving/duty cycles that match the particular capabilities of this system (that is very frequent stops and starts).

There are two types of HHVs: parallel and series. In parallel HHVs, both the engine and the hydraulic drive system are mechanically connected to the wheels. The hydraulic pump-motor is integrated into the driveshaft or differential, such as in the Lightning hydraulic hybrid system and Eaton, shown in Figure 16 and 17, respectively. A parallel hydraulic hybrid (sometimes called Hydraulic Launch Assist, or HLA) simply connects the hybrid components to a conventional transmission and driveshaft. Parallel system design keeps the traditional transmission and driveshaft system and a hydraulic pump/motor adds and subtracts power through the mechanical drive system.

Series HHVs rely entirely on hydraulic pressure to drive the wheels, which means the engine does not directly provide mechanical power to the wheels. In a series HHV configuration, an engine is attached to a hydraulic engine pump to provide additional fluid pressure to the drive pump/motor when needed, as shown in Figure 18. Series HHVs don't use a conventional transmission or driveshaft and transmit power almost directly to the wheels. Series systems eliminate a traditional transmission and driveshaft system, allowing the ground speed and engine speed to be independent of one another. This allows the engine to be turned off when not needed, like when stopped or accelerating, and for the engine to run at its best efficiency.

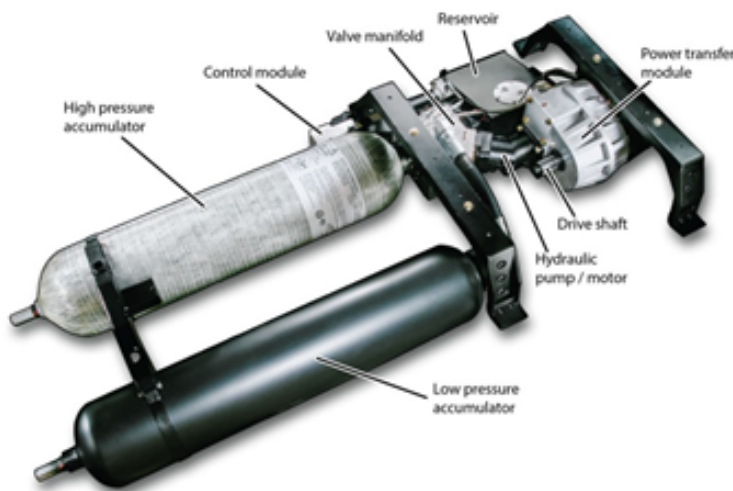
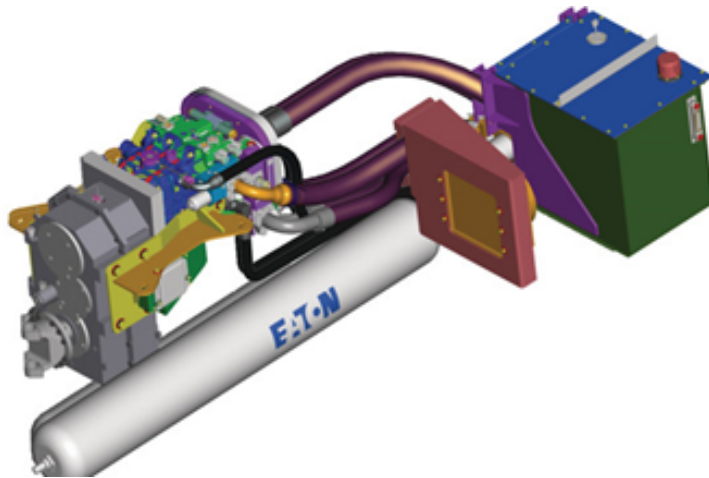
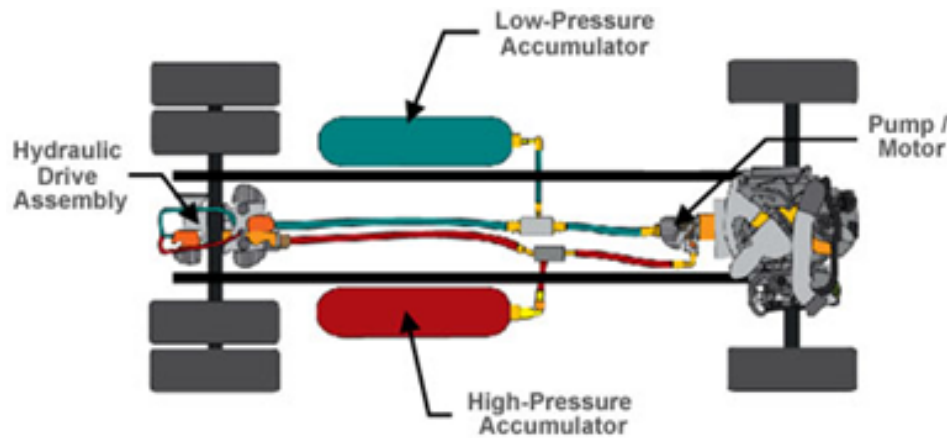

Figure 16. Hydraulic hybrid system from Lightning Hybrid



**Figure 17. Eaton parallel hydraulic hybrid system**



**Figure 18. Eaton series hydraulic hybrid system**

The hydraulic hybrid system has high power density but lower energy density. It can store a large amount of kinetic energy in a short time, but immediately gives it all back during acceleration. As a result, a hydraulic hybrid system is best suited for heavy vehicles that have frequent start-stop cycles, such as refuse trucks, delivery trucks, and transit buses [2].

### **2.2.2 Alternative Fuels**

Alternative powertrain technologies in MD and HD vehicles can be used to reduce CO<sub>2</sub> emissions by improving fuel economy. Another approach to reducing carbon emissions is to use low-carbon alternative fuels, such as biofuels, natural gas, DME, etc.

## Biofuels

Biofuels encompass a range of fuels produced from biomass, and offer a way to produce transportation fuels from agricultural sources or wastes. Biofuels can play a critical role in reducing petroleum use for transportation fuels and GHG emissions from vehicles. Ethanol, biodiesel, and renewable natural gas (RNG or biomethane) are the most common biofuels available for the transportation sector today. Corn ethanol is the most widely used biofuel in the U.S. Most of this ethanol is blended into gasoline or sold as E10, E15, and E85, for use in light duty passenger vehicles. Biodiesel is primarily produced from soybean oil and blended into petroleum diesel as B5 (5% biodiesel blended with 95% petroleum diesel) and B20, for use in MD and HD vehicles in the U.S. RNG is produced from a variety of waste resources, including landfills, sewage, farm waste, and food waste. Table 3 summarizes all biofuels produced in California and in the U.S. in 2014, and the estimated production in 2020.

**Table 3. Status of the production of various biofuels 2015-2020**

Fuel	Feedstock	California		United States		Reference sources
		2014 actual (bg/y)	2020 projected (bg/y)	2014 actual (bg/y)	2020 projected (bg/y)	
ethanol	Corn	1.6 used .22prod.		14.7 used	12 prod	California Biomass Consortium, CBMC; USEIA1
ethanol	Cellulosic	0.22 prod. -----	.40 prod.			California Biomass Consortium
biodiesel	Cooking and crop oils	0.065	0.31	1.8	2.0	USEIA1; RusTeall,workshop
Renewable diesel	Oils and adv. proc.	Mostly imports	-----	Mostly imports	-----	USEIA2
Drop-in gasoline	cellulosic	-----	-----	.5	-----	USEIA3
Renewable natural gas	Wastes and landfills	0.26 bgge/y	0.76 bgge/y	2.3 bgge/y (available)	6.1 bgge/y (potential)	CBMC; USDA August 2014
Hydrogen from biogas	Wastes and landfills	-----	-----	1.6 bgge/y (available)	4.2 bgge/y (potential)	NREL July 2014

Biodiesel is chemically different from petroleum diesel and renewable diesel because it contains oxygen atoms. Most diesel engines aren't compatible with pure biodiesel (B100). Currently, biodiesel is blended with petroleum diesel in many different concentrations. The most common are B5 and B20. The use of higher-level biodiesel blends tends to require fuel and engine parts, seals, and elastomers that are compatible with biodiesel and other usage considerations. All major OEMs selling diesel MD and HD vehicles in the U.S. support the use of

at least B5 under warranty. Some new MD and HD trucks support the use of B20 or higher biodiesel blends.

### DME (Dimethyl Ether)

DME ( $C_2H_6O$ ) is a non-toxic, non-carcinogenic fuel that can be made from biogas and natural gas. DME has a lower heating value than diesel (28.4 MJ/kg) and can be stored as a liquid at ambient temperature under 5.5 bars. DME requires simple steel fuel tanks to store it aboard a truck and is easier to handle than CNG/LNG. Diesel engines operate well using DME and need only special injection systems and different cylinder heads to handle high fuel flow. DME trucks require no particulate filters (DPF), fuel economy is on par with diesel (mpg diesel equivalent), and emissions are below US14 regulation (NOx, PM, etc.). Regarding “well to wheel” GHG emissions, DME is a good alternative to diesel, as shown in figure 19.



- WTT : DME on par with CNG
  - Can be produced locally
  - Efficient fuel transport
  - No venting (stable)
  - No high energy for transfer
  - 90% GHG reduction when obtained from biomass
- TTW
  - Similar to SI CNG,
  - Lower than Diesel

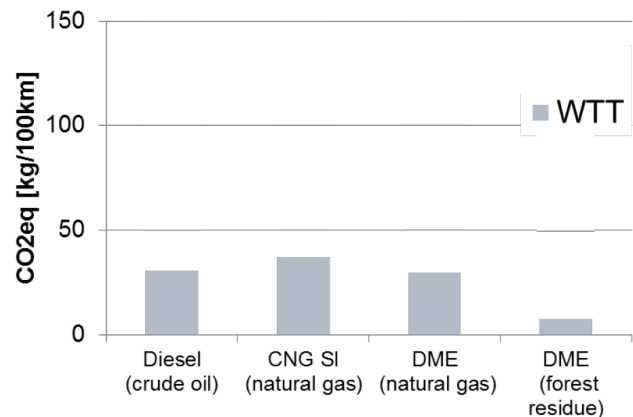

Source GHG Genius – US numbers  
 Vehicle efficiency: SI = 85% / DME = 100%, Diesel Fuel Eco = 6.5mpg

**Figure 19. Top: Volvo 435 hp DME engine and truck. Bottom: Greenhouse gas emissions using DME**

Volvo has concluded that DME as an alternative to diesel in HD trucks is better for the environment in all aspects, simpler than any other alternative fuel solution, and has the same operational efficiency as diesel. (Volvo DME: an alternative to diesel, UC Davis Dec. 3, 2015 workshop)

## Natural Gas

Natural gas as a low-carbon, clean-burning fuel is already used as a transportation fuel in municipal and fleet vehicles, including transit buses. The use of natural gas in the transportation sector can result in substantial reductions of hydrocarbon, carbon monoxide, oxides of nitrogen, and greenhouse gas emissions. The emergence of natural gas as an abundant, inexpensive fuel in the United States has raised the possibility of a larger shift in the level of natural gas utilized in the transportation sector. The cost advantages of natural gas and the diversity of its geographical sources in North America raises the possibility that natural gas can increase the global competitiveness of U.S. transportation fuel supply chains. Commercial forecasts for how much natural gas could displace oil in transportation vary widely, with high end estimates in the millions of barrels per day (mbd). That's 5% to 10% of the total available market of about 13 mbd, or more than 25% to 50% of the existing 3.9 mbd market for diesel [9].

Sustained low prices for natural gas coupled with more volatile diesel prices have accelerated market adoption of natural gas vehicles, particularly in heavy-duty markets. According to the 2015 Natural Gas Vehicle Research Roadmap, by the end of 2013, roughly 24,600 natural gas vehicles were registered in California, and about half of those fell into medium (Class 4-6) and heavy-duty vehicle classes (Class 7-8). At the same time, various near zero NOx natural gas engines have been developed for medium-duty truck, urban bus, refuse trucks, and heavy-duty line haul trucks. For example, the Cummins Westport 8.9 liter ISLG near zero natural gas SI engine (see Figure 20) has a peak rating of 320 hp, 1000 lb-ft, and is certified to the CARB optional low NOx 0.02 standard (near zero), and to 2016 EPA/NHTSA GHG standards.



**Figure 20. Cummins Westport 8.9 Liter ISLG near zero natural gas SI engine (left); Examples of a bus and refuse truck that rely on natural gas (center and right) SOURCE: Cummins Westport presentation, Fuels and Transportation Merit Review, CEC, December 2, 2015**



## 2.3 CEC Project Successes

The ARFVTP projects have helped transform California’s transportation market into a diverse collection of alternative fuel and vehicle technologies that can lead to a reduction in California’s dependence on petroleum. CEC’s ARFVTP-funded projects have contributed significantly to reducing the barriers to the future development and deployment of advanced low carbon technologies in trucks and buses. Table 4 summarizes the MD and HD vehicle demonstration projects that received ARFVTP funding up to 2015. Assembly Bill 8 recently extended ARFVT projects through 2024, at \$100 million/year.

**Table 4. ARFVTP-funded MD/HD projects by type**

Source: Larry Rillera, CEC, "Technology Merit Review: Medium- and Heavy-Duty Vehicles", December 2, 2015

Vehicle/Technology Type	Project #	Units	ARFVTP \$ (M)
Medium-Duty Hybrids, PHEVs and BEVs	8	164	\$ 15.8
Heavy-Duty Hybrids, PHEVs and BEVs	10	30	\$ 23.3
Electric Buses	7	31	\$ 14.6
Natural Gas Trucks	5	11	\$ 11.3
Fuel Cell Trucks and Buses	6	12	\$ 12.2
Vehicle-to-Grid	3	6	\$ 5.3
Off-Road Hybrids	2	2	\$ 4.5
E85 Hybrids	1	1	\$ 2.7
<b>Total</b>	<b>42</b>	<b>257</b>	<b>\$ 89.7</b>

Notable, successful examples of CEC-funded medium-duty and heavy-duty technology prototype development and manufacturing are examined in the following sections. These projects successfully demonstrated the feasibility of hybrid-electric and all-electric vehicles in performance, functionality, and reasonable durability. In some cases, the drivelines developed are being used by truck OEMs in vehicles being commercialized.

### **2.3.1 Motiv**

Two of Motiv's projects have led to commercial all-electric vehicles purchased through CARB's HVIP program: the Ameritrans ECO-Charge shuttle and the Morgan Olson electric walk-in van. Motiv expects to partner in the future with OEMs on all-electric vocational vehicles.

#### **Growth Since 2012**

- #240 on Inc's 500 Fastest Growing Private Companies in America, the company grew from 3000 ft<sup>2</sup> to 7500 ft<sup>2</sup>, with a new manufacturing facility at 1165 Chess Drive, in Hayward; Size also increased, from 17 employees to 40 employees
- Awarded over \$13.5M in grants, and received over \$12M in private investment
- 3 chassis types for vehicle applications on school buses, shuttle buses, refuse trucks, walk-in vans, delivery vans, and work trucks.

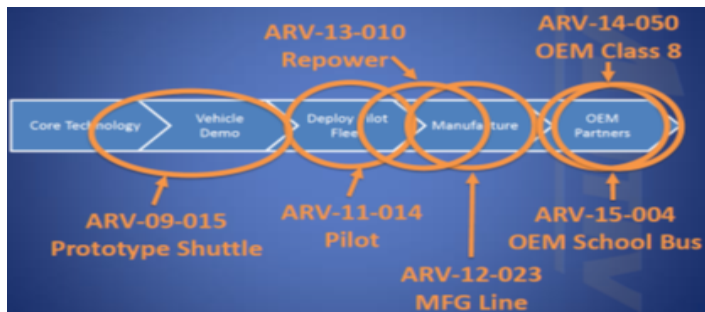

### Motiv Product Line-up

Ford E450	Ford F59	Class 8
Class 4 – 14,500 GVWR	Class 6 – 22,000 GVWR	Class 8 – 66,000 GVWR
80 – 120 miles range	70 – 110 miles range	40 – 80 miles range
8 hr charge time	8 hr charge time	8 hr charge time
School Bus (Trans Tech) Shuttle (Ameritrans) Parcel (Rockport) Flatbed (CTEC)	Parcel (Morgan Olson) Linen (Morgan Olson)	Refuse (Loadmaster) Drayage

Figure 21. Motiv Power: Example of vehicles in demonstration phase (top), including a refuse truck, a school bus, an “Eco-Charge” community shuttle, and a delivery truck; From pilot to commercial diagram (center); and Three primary chassis underlying Motiv demonstration vehicles (bottom).

### 2.3.2 TransPower

TransPower, in San Diego, received \$16M in contracts for 20 trucks (16 port drayage trucks, 3 refuse trucks, and 1 advanced delivery truck). The company produces modular electric drive system components for Class 8 port trucks, yard tractors, and school buses, and has also developed electric class 8 on-road trucks that are the first fully-functional electric trucks of this class. TransPower is partnering with major truck OEMs such as Navistar and Peterbilt.



**Figure 22. TransPower Demonstration Vehicles: Electric Truck Tractor, cab alone (left), attached to trailer (right) (top)**

**Electric Yard Tractors** have been proven the most efficient electric yard tractors in use today.

Technology highlights include:

- First commercial-grade tractor completed its first year of use at IKEA's California distribution center (15,000+ miles)
- Four additional tractors currently in use
- \$4M received in 2015 for 7 additional tractors, to be operated by IKEA, Dole, Grimmway Farms, and Harris Ranch
- Seeking additional funds for distribution center and port tractors in 2016-17
- Expanding relationship with Kalmar for large scale manufacturing



**Figure 23. TransPower Demonstration Vehicles: Electric Yard Tractor, attached to trailer (right)**

**Electric School Buses** High-power electric school buses, proven in service

- Converted largest bus model (40') to electric drive in 2013 – approved by California Highway Patrol and used to transport high school students in 2014
- Partnered with Clinton Global Initiative and funded (\$2M) to convert six mid-sized (26') buses for use by three California school districts starting in 2016
- Seeking funding and major OEM support for an expanded (~35 electric buses) demonstration in 2016-17



**Figure 24. “High-power” electric school bus; used to transport high school students in California in 2014**

**Medium & Heavy-Duty Vehicle Fleet Expansion** *TransPower*

**Total TransPower vehicles in California at year-end (actual 2014-15, planned 2016-17):**

	2014	2015	2016	2017
<b>Prototype Vehicles in Testing – All Types</b>	3	5	8	12
<b>Vehicles in Full Service</b>				
Electric Class 8 Trucks	2	6	16	41
Electric Yard Tractors	3	5	14	26
Electric School Buses	0	1	10	42
Hybrid Class 8 Trucks	0	0	8	12
Other Cargo Handlers	1	1	2	4
<b>TOTAL VEHICLES IN OPERATIONAL SERVICE</b>	<b>6</b>	<b>13</b>	<b>50</b>	<b>125</b>

Figure 25. TransPower California Fleet, current and near future SOURCE: TransPower Presentation, “Adaptation of Common, Modular Electric Drive System Elements to Class 8 Port Trucks, Yard Tractors, and School Buses.” CEC Fuels and Transportation Merit Review, December 2, 2015

**2.3.3 Wrightspeed Powertrains**



Figure 26. Wrightspeed powertrains, with fulcrum turbine (right) SOURCE: Wrightspeed Presentation, “Powertrains - Scaling up,” CEC, CEC Fuels and Transportation Merit Review, December 2, 2015

Wrightspeed's generator burns cleaner per kWh than the average mix of US electric power plants, making Wrightspeed's products cleaner, on average, than EVs.

#### Wrightspeed's milestones in its first 5 years

- Sept. 2010: First funding and first CEC grant, for \$1.2m, to build 4 prototypes
- Nov. 2011: First truck on the road
- June 2012: CEC grant, for \$5.7m, establishes production facility
- Nov 2013: First ship to FedEx
- Feb 2014: First Refuse truck order
- May 2015: Announce Fulcrum turbine
- Feb 2016: Moved to Alameda factory; backlog of 42 vehicles
- Present status: First bus orders in process

## 2.4 References

- [1] CARB, Draft, Technology Assessment: Medium- and Heavy-Duty Battery Electric Trucks and Buses, October 2015.
- [2] Seven Eick, Select Engineering Services (SES) and Automotive Insight, LLC, Technical Report: Heavy Duty Diesel Truck and Bus Hybrid Powertrain Study, 2012
- [3] M. Lammert, NREL Technical Report: Long Beach Transit: Two-Year Evaluation of Gasoline-Electric Hybrid Transit Buses, NREL/TP-540-42226, June 2008
- [4] Tim M. Grewe, Brendan M. Conlon and Alan G. Holmes, Defining the General Motors 2-Mode Hybrid Transmission, SAE 2007-01-0273
- [5] CARB Heavy-Duty Hybrid Vehicles Technology Assessment, September 2, 2014 and April 22, 2015
- [6] NHTSA, Commercial Medium- and Heavy-Duty Truck Fuel Efficiency Technology Study – Report #1, DOT HS 812 146, June 2015
- [7] CARB Technology Assessment: Heavy-Duty Hybrid Vehicles (draft), November, 2015
- [8] HTUF Commercial Truck Action Group (CTAG) Kick-Off Meeting, February 20, 2013, Pasadena, California
- [9] Jaffe, Amy Myers, et al. Exploring the Role of Natural Gas in US Trucking. No. UCD-ITS-RR-15-05. 2015.



### 3. Drivers for marketing of alternative trucks

#### 3.1 EPA/NHTSA standards for fuel efficiency and CO<sub>2</sub> emissions

EPA and NHTSA are setting fuel efficiency and CO<sub>2</sub> engine and vehicle standards for medium- and heavy-duty trucks. The first set of these standards (Phase 1) were finalized in August 2011 [1]. A proposed second set of standards (Phase 2) were published in June 2015 [2]. The Phase 1 standards are in effect from 2014-2017 and the Phase 2 standards will be applicable from 2018-2027. These standards apply to vehicles with Gross Vehicle Weight (GVWR) greater than 8500 lbs. (3.9 metric tons), generally referred to as medium-duty and heavy-duty vehicles. The vehicle classes covered are Class 2b through Class 8. The standards are given for both the engines in the vehicles and the vehicles as a whole. References [1] and [2] discuss, in great detail, the standards, how they were developed, what is required to meet them and related costs, how vehicles and engines are certified, and their environmental consequences. Both references are very long reports (600-1000 pages) and serve as excellent sources of information on present and future design options for Class 2-8 trucks and their effect on fuel efficiency and CO<sub>2</sub> emissions.

The standards apply to three general types of trucks: (1) Commercial pickups and vans, (2) Vocational trucks, and (3) Long-haul tractor-trailers and buses. All of these vehicle types use heavy-duty engines as opposed to similar gasoline and diesel engines used in light-duty vehicles, such as passenger cars. The most diverse of these vehicle types is the vocational truck type, which includes box, bucket work, refuse, and local delivery trucks, shuttle buses, etc. Setting standards for this complex and diverse set of vehicles, attempting to account for how the vehicles are used and the payload they carry, was a difficult task. The solution to the problem was to use the metric, gal/1000 ton-mi, for fuel efficiency and gram CO<sub>2</sub>/ton-mi for the CO<sub>2</sub> emissions. The “ton” refers to the payload that the vehicle carries.

Determining an appropriate payload for each type of vehicle is not simple, as the payload varies markedly as the vehicle is loaded and unloaded as it is used. This problem is discussed, in some detail, in References [1] and [2], for the various vehicle types. For pickups, there is the problem of including the towing capability of the vehicle in addition to its payload. This is done by defining a work factor, which is a combination of the towing capacity and payload. The work factor, WF, is defined as  $WF = .75 \times (\text{Payload}) + .25 \times (\text{towing capacity})$ . For the pickups and the vans, the fuel efficiency and CO<sub>2</sub> emission metrics are gal/100 mi and gmCO<sub>2</sub>/mi, respectively. The relationships between the metrics and the work factor are given in References [1] and [2].

EPA has also established standards for the engines to be used in heavy duty vehicles. The metrics for these standards are gal/bhp-hr and gmCO<sub>2</sub>/bhp-hr for fuel efficiency and CO<sub>2</sub> emissions, respectively. The engines are tested using the same procedures as set by EPA to measure CO, HC, NO<sub>x</sub>, and particulate emissions. The factors relating a gallon of fuel and grams CO<sub>2</sub> are 10,100 (i.e. grams in a gallon) for diesel fuel and 8,910 for gasoline.

Except for the heavy-duty pickups and vans that will be tested on a chassis dynamometer, the medium- and heavy-duty vehicles will be certified based on computer simulations using a computer code GEM (Greenhouse gas Emissions Model) developed by EPA. The GEM and the inputs used for the vehicle simulations in order to develop the standards are discussed in detail in References [1] and [2]. Testing to determine appropriate values for the inputs needed for the GEM simulations and to validate the GEM simulations for various vehicle types is detailed in Reference [3].

The EPA/NHTSA standards for fuel efficiency and CO<sub>2</sub> emissions for various types of vehicles and engines for 2014 to 2027 are summarized in Tables 5 -7. The values given in Tables 5 and 7 have been taken from References [1] and [2]. More complete summaries of the Phase 1 (2014-2017) standards are given in References [4] and [5]. The CO<sub>2</sub> emissions standards corresponding to the fuel efficiency standards for the various vehicle types are given in Table 7.

**Table 5. Summary of EPA/NHTSA Phase 1 and Phase 2 Heavy-duty fuel efficiency standards**

Truck type	2010 baseline gal/ 10 <sup>3</sup> ton-mi	2014 standard gal/ 10 <sup>3</sup> ton-mi	2017 standard gal/ 10 <sup>3</sup> ton-mi	2027 standard gal/ 10 <sup>3</sup> ton-mi	Payload Metric tons	2010 baseline mpg *	2027 Mpg
Class 7 day cab mid roof diesel	12.6	11.7	11.3	9.4	11.4	7.0	9.33
Class 8 day cab mid roof diesel	9.4	8.7	8.4	7.5	17.3	6.15	7.7
Class 8 sleeper cab mid roof diesel	8.7	7.4	7.2	6.8	17.3	6.64	8.5
Vocational vehicles diesel							
Light-heavy Class 2b-5	40.0	38.1	36.7	27.5	2.85	8.77	12.75
Medium-heavy Class 6-7	24.3	23.0	22.1	17.1	5.6	7.35	10.4
Heavy-heavy Class 8	23.2	22.2	21.8	18.0	7.5	5.75	7.4
	baseline	2014	2018	2027			
Heavy duty vans and pickup trucks	gal/100 miles	gal/100 miles	gal/100 miles	gal/100 miles	Work factor Metric tons	2010 baseline mpg	2027 Mpg
Diesel	7.4	6.15	5.6	4.64	2.6	13.5	21.6
gasoline	8.3	7.28	6.68	5.6	2.6	12.05	17.85

\*gal/mi = (gal/10<sup>3</sup> ton-mi)x payload/1000

**Table 6. Summary of the engine fuel efficiency standards for Phase 1 and Phase 2**

	2014	2017	2021	2027
Engine type	gal/10 <sup>2</sup> bhp-hr/ efficiency*	gal/10 <sup>2</sup> bhp-hr/ efficiency	gal/10 <sup>2</sup> bhp-hr/ efficiency	gal/10 <sup>2</sup> bhp-hr/ efficiency
Diesel MD**	4.93 / .37	4.78 / .383	4.71 / .388	4.58 / .400
Diesel HD	4.67/ .392	4.52 / .405	4.45 / .411	4.33 / .423
Gasoline MD	7.43 / .273	7.06 / .288		

\*engine efficiency= 1.83/(engine metric) for diesel: engine efficiency= 2.03/(engine metric) for gasoline

\*\* gmCO<sub>2</sub>/bhp-hr = 101.52 (gal/10<sup>2</sup> bhp-hr) for diesel, gmCO<sub>2</sub>/bhp-hr = 89.1 (gal/10<sup>2</sup> bhp-hr) for gasoline

**Table 7. Summary of EPA/NHTSA Phase 1 and Phase 2 Heavy-duty CO<sub>2</sub> emissions standards**

Truck type	2010 baseline gmCO <sub>2</sub> / ton- mi *	2014 gmCO <sub>2</sub> / ton-mi	2017 gmCO <sub>2</sub> / ton- mi	2027 gmCO <sub>2</sub> / ton-mi	Payload Metric tons		2010 baseline mpg	2027 mpg
Class 7 day cab mid roof diesel	128	119	115	96	11.4		7.0	9.33
Class 8 day cab mid roof diesel	96	88	85	76	17.3		6.15	7.7
Class 8 sleeper cab mid roof diesel	88	75	73	69	17.3		6.64	8.5
Vocational vehicles diesel								
Light-heavy Class 2b-5	406	387	373	279	2.85		8.77	12.75
Medium-heavy Class 6-7	246	233	224	174	5.6		7.35	10.4
Heavy-heavy Class 8	235	225	221	183	7.5		5.75	7.4

Truck type	2010 baseline gmCO <sub>2</sub> / ton-mi *	2014 gmCO <sub>2</sub> / ton-mi	2017 gmCO <sub>2</sub> / ton-mi	2027 gmCO <sub>2</sub> / ton-mi	Payload Metric tons	2010 baseline mpg	2027 mpg
	baseline	2014	2018	2027			
Heavy duty vans and pickup trucks	gmCO <sub>2</sub> /mi	gmCO <sub>2</sub> /mi	gmCO <sub>2</sub> /mi	gmCO <sub>2</sub> /mi	Work factor Metric tons	2010 baseline mpg	2027 Mpg
Diesel	782	624	569	471	2.6	13.5	21.6
gasoline	739	649	595	499	2.6	12.05	17.85

\* gmCO<sub>2</sub>/mi = (gal/10<sup>3</sup> ton-m) x (gmCO<sub>2</sub>/gal)/1000; gmCO<sub>2</sub>/gal=10152 for diesel, 8910 for gasoline

As indicated in Table 5, the Phase 1 fuel efficiency standards require an improvement of about 10-24% in the fuel efficiency (i.e. fuel consumption of the vehicles) and a corresponding 10-24% reduction in the CO<sub>2</sub> emissions. The improvement in Phase 1 for all types is dependent on the values selected for the 2010 baseline fuel economy.

The baseline fuel economy values for the various truck types were not easy to identify in the Rulemaking reports, i.e. References [1] and [2]. The GEM simulations indicate that Phase 1 improvements can be achieved without using advanced technologies, e.g. hybrid-electric powertrains, but rather require only modest improvements in aerodynamics, rolling resistance, and engine efficiency, and relatively small reductions in weight. The GEM simulations also indicated that Phase 2 standards could be met, in most cases, with more aggressive improvements in vehicle weight and road load parameters coupled with further increases in engine efficiency. For Phase 2, there may be some utility in hybridizing the driveline, but such advanced technologies were in fact not deemed essential to meeting the Phase 2 standards.

It is of interest to note the reductions in fuel consumption and CO<sub>2</sub> emissions between Phase 1 and 2. The improvements required by Phase 2 as compared to Phase 1 vary rather widely (6-28%) for the various truck types, with the smaller values covering the heavy duty long-haul trucks and the larger reductions covering the vocational and pickup trucks. The total reductions for Phase 1 and 2, combined, tend to be more uniform (28-38%) with truck type. The percentage improvement in Phase 2 depends on both the baseline and the payload selected for the comparison.

Most of the discussions in the Rulemaking reports concerned the use of diesel engines with SCR for emissions after-treatment to meet the 2010 NO<sub>x</sub> standard of .2 gm/bhph, and filters to meet the particulate emissions standards. Limited consideration was given to the use of gasoline

engines and alternative fuels, such as natural gas. The focus was on the efficient use of diesel engines. The increases in engine efficiency required by Phases 1 and 2 have been summarized in Table 6.

EPA/NHTSA has performed detailed cost studies related to meeting Phase 1 and Phase 2 standards. As shown in Tables 8 - 10, taken from Reference [2], the additional costs of the vehicles meeting the 2027 standards are modest and the payback periods are less than 2 years for long-haul, diesel fueled trucks and 3-5 years for heavy-duty vocational and pickup trucks for discount rates of 3-7%. The AEO2014 Early Release was used in the analysis to predict the diesel fuel and gasoline prices from 2014 to 2027. For that period, the price of diesel fuel was projected to vary between \$2.5 and \$3.5/gal and gasoline to range between \$2 and \$3/gal. The projections (Reference [6]) included both the high prices of 2014 and the sharp decrease of 2015 followed by a gradual increase out to 2027.

The cost studies indicate that the Phase 1 and 2 standards, combined, are cost effective for the reasonably low fuel prices assumed. This means that a strong business case can be made for the technology improvements to meet the Phase 1 standards. This is especially true for the long-haul tractor/trailer trucks, which use very large amounts of fuel per year; however, for the long-haul trucks, most of the fuel cost saving is due to the Phase 1 standards, while most of the additional cost is incurred to meet the smaller Phase 2 fuel savings (only 6%). For this case, the additional vehicle cost to meet the Phase 2 standards may not be cost effective.

**Table 8. Discounted Expenditures & Payback Period for MY2027 Tractor/Trailers under the Preferred Alternative Vs. The Less Dynamic Baseline and using Method B 3% and 7% Discount Rates (2012\$)\***

Age	3% Discount Rate				7% Discount Rate			
	Technology cost, taxes, insurance <sup>b</sup>	Maintenance expenditures	Fuel expenditures <sup>c</sup>	Cumulative expenditures	Technology cost, taxes, insurance <sup>b</sup>	Maintenance expenditures	Fuel expenditures <sup>c</sup>	Cumulative expenditures
1	\$15,194	\$48	-\$14,649	\$593	\$14,914	\$47	-\$14,379	\$582
2	\$238	\$46	-\$14,204	-\$13,327	\$225	\$43	-\$13,421	-\$12,571
3	\$223	\$44	-\$13,809	-\$26,869	\$203	\$40	-\$12,561	-\$24,889
4	\$209	\$42	-\$13,416	-\$40,034	\$183	\$37	-\$11,746	-\$36,415
5	\$195	\$39	-\$12,391	-\$52,191	\$164	\$33	-\$10,443	-\$46,661
6	\$182	\$35	-\$11,411	-\$63,385	\$148	\$29	-\$9,258	-\$55,743
7	\$170	\$32	-\$10,511	-\$73,694	\$133	\$25	-\$8,209	-\$63,794
8	\$158	\$29	-\$9,704	-\$83,211	\$119	\$22	-\$7,295	-\$70,949

Notes:

<sup>a</sup> For an explanation of analytical Methods A and B, please see Preamble Section I.D; for an explanation of the less dynamic baseline, 1a, and more dynamic baseline, 1b, please see Preamble Section X.A.1

<sup>b</sup> 6% sales tax and 12% excise tax; insurance estimates are described in text.

<sup>c</sup> Fuel expenditures calculated using retail fuel prices according to AEO2014 early release, reference case estimates.

**Table 9. Discounted Owner Expenditures & Payback Period for MY 2027 Vocational Vehicles under the Preferred Alternative Vs. The Less Dynamic Baseline and using Method B 3% and 7% Discount Rates (2012\$)\***

Age	3% Discount Rate				7% Discount Rate			
	Technology cost, taxes, insurance <sup>b</sup>	Maintenance expenditures	Fuel expenditures <sup>c</sup>	Cumulative expenditures	Technology cost, taxes, insurance <sup>b</sup>	Maintenance expenditures	Fuel expenditures <sup>c</sup>	Cumulative expenditures
1	\$3,998	\$10	-\$965	\$3,043	\$3,924	\$10	-\$947	\$2,987
2	\$63	\$9	-\$937	\$2,178	\$59	\$9	-\$885	\$2,169
3	\$59	\$9	-\$914	\$1,331	\$53	\$8	-\$832	\$1,399
4	\$55	\$9	-\$891	\$504	\$48	\$8	-\$780	\$675
5	\$51	\$8	-\$829	-\$265	\$43	\$7	-\$699	\$27
6	\$48	\$7	-\$771	-\$981	\$39	\$6	-\$625	-\$554
7	\$45	\$7	-\$716	-\$1,645	\$35	\$5	-\$559	-\$1,073
8	\$42	\$6	-\$667	-\$2,264	\$31	\$5	-\$501	-\$1,538

Notes:

<sup>a</sup> For an explanation of analytical Methods A and B, please see Preamble Section I.D; for an explanation of the less dynamic baseline, 1a, and more dynamic baseline, 1b, please see Preamble Section X.A.1

<sup>b</sup> 6% sales tax and 12% excise tax; insurance estimates are described in text.

<sup>c</sup> Fuel expenditures calculated using retail fuel prices according to AEO2014 early release, reference case estimates.

**Table 10. Discounted Owner Expenditure & Payback Period for MY2027 HD Pickups & Vans under the Preferred Alternative Vs. The Less Dynamic Baseline and using Method B 43% and 7% Discount Rates (2012\$)\***

Age	3% Discount Rate				7% Discount Rate			
	Technology cost, taxes, insurance <sup>b</sup>	Maintenance expenditures	Fuel expenditures <sup>c</sup>	Cumulative expenditures	Technology cost, taxes, insurance <sup>b</sup>	Maintenance expenditures	Fuel expenditures <sup>c</sup>	Cumulative expenditures
1	\$1,587	\$4	-\$759	\$832	\$1,558	\$3	-\$745	\$817
2	\$25	\$3	-\$734	\$126	\$23	\$3	-\$694	\$150
3	\$23	\$3	-\$714	-\$561	\$21	\$3	-\$649	-\$476
4	\$22	\$3	-\$693	-\$1,229	\$19	\$3	-\$606	-\$1,060
5	\$20	\$3	-\$651	-\$1,857	\$17	\$2	-\$549	-\$1,590
6	\$19	\$3	-\$611	-\$2,446	\$15	\$2	-\$496	-\$2,067
7	\$18	\$2	-\$571	-\$2,997	\$14	\$2	-\$446	-\$2,497
8	\$16	\$2	-\$536	-\$3,514	\$12	\$2	-\$403	-\$2,886

Notes:

<sup>a</sup> For an explanation of analytical Methods A and B, please see Preamble Section I.D; for an explanation of the less dynamic baseline, 1a, and more dynamic baseline, 1b, please see Preamble Section X.A.1

<sup>b</sup> 6% sales tax; insurance estimates are described in text.

<sup>c</sup> Fuel expenditures calculated using retail fuel prices according to AEO2014 early release, reference case estimates.

### The California position on the proposed Phase 2 standards

The position of California on the proposed Phase 2 standards for medium- and heavy-duty vehicles is presented in detail in Reference [7]. Even though CARB staff worked closely with the staffs of EPA and NHTSA on the analyses that paved the way for the Phase 2 standards, CARB

has concluded that the stringency of the Phase 2 standards will not meet the petroleum use and CO<sub>2</sub> emission reduction goals of California. In addition, the Phase 2 standards do not require further reductions in engine NO<sub>x</sub> emissions beyond the 2010 standard, which is important for meeting the air quality standards in California.

California is concerned about both the timing and the stringency of the Phase 2 standards. As proposed, the most stringent of the Phase 2 standards become effective in 2027. CARB recommends that those standards become effective in 2024. As indicated in Table 2, EPA/NHTSA is proposing a relatively modest increase of 7.5% in the engine efficiency standard between 2014 and 2027. The R&D in the DOE SuperTruck program by large engine manufacturers indicated that for diesel engines the maximum efficiency of the engine can be improved from the present value of 42% to 50% or even higher. This is an increase of 16%, or double that proposed by EPA for 2027.

California is also concerned about the relatively modest decrease in CO<sub>2</sub> emissions proposed in the Phase 2 standards (see Table 7). This is especially the case for long-haul trucks, for which the decrease is only 6-10% between 2017 and 2027. The decrease is larger (17-22%) for vocational and pickup trucks, but still modest in magnitude. As indicated in the CARB comments [7], EPA/NHTSA have not been aggressive regarding improvements in aerodynamic drag (decreases in C<sub>D</sub>A) and the use of advanced technologies, such as hybrid-electric drivelines, battery energy storage, or fuel cells, all of which could greatly reduce petroleum fuel consumption and CO<sub>2</sub> emissions. Hence it seems apparent that much larger reductions in CO<sub>2</sub> emissions for medium- and heavy-duty vehicles are possible than those proposed for Phase 2.

CARB has performed studies [8] [9] [10] of advanced technology applications for medium- and heavy-duty trucks. It was found that the improvements in fuel economy and reductions in CO<sub>2</sub> emissions vary greatly depending on the driving cycle, but can be as high as 70% in urban driving. These advanced technologies are well suited to vocational vehicles such as refuse trucks, shuttles, school buses, transit buses, etc., which operate in urban areas. Both CEC and CARB grant programs for vehicle demonstrations are focused on the application of advanced technologies in medium-duty delivery vehicles and heavy-duty vocational vehicles. Indeed, these applications will benefit most from the use of these advanced technologies.

### **3.2 Federal and California Engine Emission Standards**

As noted in the previous section, EPA/NHTSA has set standards for vehicle fuel efficiency and CO<sub>2</sub> emissions for various types of medium/heavy duty trucks. As part of the same set of regulations, EPA/NHTSA set standards for fuel use and CO<sub>2</sub> emissions (see Table 11). The metrics for those regulations are gal/100 bhp-hr and gm CO<sub>2</sub>/bhp-hr, respectively. The engine efficiency is related to the fuel use metric as follows:

$$\text{engine efficiency} = 1.83 / (\text{gal}/10^2 \text{ bhp-hr}) \text{ for diesel}$$

$$\text{engine efficiency} = 2.03 / (\text{gal}/10^2 \text{ bhp-hr}) \text{ for gasoline}$$

These efficiencies are not the maximum efficiency of the engine, but are a measure of the efficiency on a driving cycle in which the engine operating point varies with time over the engine map. The engine emissions are also related to the engine fuel metric:

$$\text{gmCO}_2/\text{bhp-hr} = 101.52 \text{ (gal/10}^2 \text{ bhp-hr) for diesel,}$$

$$\text{gmCO}_2/\text{bhp-hr} = 89.1 \text{ (gal/10}^2 \text{ bhp-hr) for gasoline}$$

The agencies consider these efficiency increases to be modest and achievable by evolving improvements in engine technology.

**Table 11. Summary of the engine fuel efficiency standards for Phase 1 and Phase 2**

	2014	2017	2021	2027
Engine type	gal/10 <sup>2</sup> bhp-hr/ efficiency*	gal/10 <sup>2</sup> bhp-hr/ efficiency	gal/10 <sup>2</sup> bhp-hr/ efficiency	gal/10 <sup>2</sup> bhp-hr/ efficiency
Diesel MD	4.93 / .37	4.78 / .383	4.71 / .388	4.58 / .400
Diesel HD	4.67 / .392	4.52 / .405	4.45 / .411	4.33 / .423
Gasoline MD	7.43 / .273	7.06 / .288		

In addition to fuel efficiency and greenhouse gas standards, the engines must also meet pollution standards related to air quality. These standards are particularly important to air quality in California. The most important of these pollutant standards are those for NOx and particulates (PM). The standards are given in terms of g/bhp-hr for the engine tested on the heavy-duty transient test procedure and the ramped modal cycle supplemental emissions test cycle prescribed by EPA (Ref. [11]). The 2010 emissions limits are .2 g/bhp-hr for NOx and .01g/bhp-hr for g/bhp-hr for PM.

California is implementing optional low NOx standards that will reduce the NOx emissions by 50, 75, 90 percent lower than the 2010 standard. This would reduce the engine NOx emissions to .02 g/bhp-hr. For diesel engines (Ref [12]), the .02 NOx emission standard can be met by further development of the SCR (selective catalytic reduction) technology presently used on trucks. In the case of gasoline and natural gas engines, the low emissions standard can be met using the 3-way catalyst, O2-sensor technology (Ref [13]). For diesel engine, meeting the PM standard will likely require the use of DPF particulate filters. Heavy-duty engines that meet the optional NOx standards will be eligible for incentive funding.



### 3.3 Federal and California incentives for trucks and buses

As noted previously, NHTSA and DOE claim that the Phase 1 and 2 standards can be met without the use of the advanced technologies, with a payback period of 3 years or less. The resulting improvement in fuel consumption would be about 25-30%. The cost information on the advanced systems given in Tables 12 and 13 indicates that their costs will be much higher than for the systems using improved conventional technology. Hence, in order to promote the commercial market for the advanced technologies, financial incentives will be needed to reduce both the effective initial costs of these vehicles and the payback periods to less than 3-5 years. These incentives would be justified, because the CO<sub>2</sub> emission reductions of the advanced, alternative vehicles are expected to be markedly greater than those satisfying the Phase 2 standards.

California has established the HVIP program to offer incentives to fleets to purchase hybrid and electric trucks and buses and natural gas fueled (90% of time) MD/HD trucks. PHEV light-duty trucks can also qualify for the HVIP program. The vehicles are pre-qualified by CARB. The qualified hybrid-electric vehicles must demonstrate, during testing, at least a 30% reduction in fuel consumption compared to a baseline conventional vehicle. All-electric vehicles must also be pre-qualified by CARB. Eligible vehicles for the HVIP program cannot be demonstration vehicles, but rather must be in at least limited production. The financial incentive for each eligible vehicle is pre-determined by CARB and, in general, varies with gross vehicle weight (GVW). The incentives for the various GVW classes are shown in Tables 12 and 13.

**Table 12. E-Truck and Bus Voucher Amounts**

GVWR (lbs)	Base Vehicle Incentive		
	1 to 100 vehicles <sup>1</sup>		101 to 200 vehicles
	Outside DC <sup>2</sup>	Within DC <sup>2</sup>	
5,001 – 8,500	\$20,000	\$25,000	\$12,000
8,501 – 10,000	\$25,000	\$30,000	\$18,000
10,001 – 14,000 <sup>3</sup>	\$50,000	\$55,000	\$30,000
14,001 – 19,500	\$80,000	\$90,000	\$35,000
19,501 – 26,000	\$90,000	\$100,000	\$40,000
> 26,000	\$95,000	\$110,000	\$45,000

1 - The first three vouchers received by a fleet, inclusive of previous funding years, are eligible for the following additional funding amount: \$2,000/vehicle if below 8,501 lbs; \$5,000/vehicle if 8,501 to 10,000 lbs; and \$10,000/vehicle if over 10,000 lbs.

2 - 'DC' refers to a disadvantaged community.

3 - This weight range is not intended for vehicles utilizing a pick-up truck chassis/platform typically found in vehicles below 10,001 lbs GVWR. Vehicles at the lower end of the 10,001 to 14,000 lbs weight range will be evaluated on a case-by-case basis to determine eligibility for the full Base Vehicle Incentive.

**Table 13. Hybrid Truck and Bus Voucher Amounts**

GVWR (lbs) <sup>1</sup>	Base Vehicle Incentive	
	1 to 100 vehicles <sup>2</sup>	101 to 200 vehicles
6,001 – 8,500 (plug-in hybrids only) <sup>3</sup>	\$ 8,000	\$ 6,000
8,501 – 10,000 (plug-in hybrids only) <sup>3</sup>	\$10,000	\$ 8,000
10,001 – 19,500	\$15,000	\$10,000
19,501 – 33,000	\$20,000	\$12,000
33,001 – 38,000	\$25,000	\$15,000
> 38,000	\$30,000	\$20,000

1 - Tractor trailers utilize Gross Combined Vehicle Weight for purposes of determining Base Vehicle Incentive.

2 - The first three HVIP vouchers received by a fleet, inclusive of previous funding years, are eligible for the following additional funding amount: \$2,000/vehicle if below 8,501 lbs; \$5,000/vehicle if 8,501 to 19,500 lbs; and \$10,000/vehicle if over 19,500 lbs.

3 - Vehicle must be ARB-certified as an Ultra-Low Emission Vehicle. Voucher amount is increased by \$2,000 for each of the following: ARB-certification as a Super Ultra Low Emission Vehicle and ARB-certification for zero-evaporative emissions.

### **HVIP Adder Funds to Increase Voucher Amounts**

There are additional funds available for individual vouchers beyond the "first three" adder described in the tables above. These include:

- Plug-In or Hydraulic Hybrid Vehicles
- Hybrid or Zero-Emission School Buses

### 3.4 References

- [1]. EPA/NHTSA, Greenhouse Gas Emissions Standards and Fuel Efficiency Standards for Medium- and Heavy-Duty Engines and Vehicles, Phase 1, Final rules, Aug 9, 2011 in the Federal Register
- [2]. EPA/NHTSA, Proposed Rulemaking for Greenhouse Gas Emissions and Fuel Efficiency Standards for Medium- and Heavy-duty Engines and Vehicles-Phase 2, EPA-420-D-15-900, June 2015
- [3]. Southwest Research Institute Workshop on validation testing For GEM, San Antonio, Texas, December 10, 2014
- [4]. U.S. Greenhouse Gas Emissions and Fuel Efficiency Standards for Medium- and Heavy-duty Engines and Vehicles, ICCT Policy Update Number 14, September 23, 2011
- [5]. Harrington, W. and Krupnick, A., Improving Fuel Economy in Heavy-duty Vehicles, Resources for the Future, Issue brief 12-01, March 2012
- [6]. U.S. Eia, Annual Energy Outlook for 2015, April 2014
- [7]. Letter and attachments from California EPA to USEPA/NHTSA concerning Phase 2 standards, October 1, 2015
- [8]. CARB report, Technology Assessment: Heavy-duty hybrid vehicles (draft), November 2015
- [9]. CARB report, Technology Assessment: Medium- and heavy-duty battery electric trucks and buses (draft), November 2015
- [10]. CARB report, Technology Assessment: Medium- and heavy-duty Fuel Cell Electric vehicles (draft), November 2015
- [11]. EPA engine test procedures
- [12]. Technology Assessment: Lower NOx Heavy-duty diesel engines, Air Resources Board Report, September 2015o
- [13]. Pathways to Near-zero Emission Natural Gas Heavy-duty Vehicles, Gladstein, Neandross & Associates White Paper, updated May 19, 2014

## 4. Barriers to Market Development

### 4.1 Structure of Manufacturing and Sales Markets for Trucks and Buses

In the mature truck markets, original equipment manufacturers (OEMs) integrate components into their truck platform and sell the final products. The Class 8 market is dominated by the OEMs - e.g. Freightliner, Kenworth, Peterbilt, International, and Volvo. Companies manufacturing battery-electric or fuel cell buses tend to follow a similar pattern. However, companies producing battery-electric or fuel cell trucks are not the truck OEMs. These companies tend to be smaller and newer, and they generally focus on producing drivelines and energy storage systems which they then integrate into truck platforms from other manufacturers, sometimes the truck OEMs. The structure of the manufacturing and sales market for advanced technology buses has remained much the same as for conventional diesel buses, but as discussed below there are exceptions especially in the case of battery electric or fuel cell buses.

The major fuel cell bus manufacturers selling into the US market, New Flyer and Van Hool, are bus OEMs that have produced diesel buses for many years. These companies have partnered with fuel cell manufacturers such as Ballard and US Hybrid and integrated the fuel cell systems into their bus platforms. Battery electric bus manufacturers are also OEMs making their bus chassis, but the dominant US companies in this market, i.e. Proterra and BYD, are younger companies new to the bus market. Both Proterra and BYD began making buses relatively recently and do not sell conventional diesel buses. They do continue to follow the conventional structure for the manufacturing and sales market by integrating components into their bus platforms and selling those buses.

The battery electric and fuel cell truck markets are dominated by smaller, newer companies which generally do not produce the truck chassis. These companies specialize in the integration of advanced driveline components into truck platforms. Examples of such companies are the following:

- **Transpower** specializes in integrated drive systems and energy storage systems for both electric and fuel cell trucks specializing in large port and warehouse applications.
- **Odyne** uses Freightliner, Kenworth, and International chassis. They manufacture hybrid systems for medium- and heavy-duty work trucks.
- **Orange EV** converts terminal trucks to battery electric vehicles.
- **Motiv** offers a new, clean powertrain to US truck manufacturers. They manufacture an all-electric powertrain.

Not all companies producing battery-electric trucks are just integrators. Workhorse (Amp Electric) is an OEM that manufactures delivery trucks.

The new, smaller companies receive significant public funds to demonstrate their trucks. This funding is critical to the operation of these companies. **Transpower** has received grants from a wide variety of sources such as the CEC, US DOE, the Ports of Long Beach and Los Angeles, the US EPA, and the SCAQMD [1, 2]. **Odyne** has grants from the CEC, the US DOE, and the SCAQMD

[3, 4]. **Orange EV** is producing terminal trucks in the Chicago region using funds from the federal Congestion Mitigation Air Quality (CMAQ) program [5]. The company is also producing trucks for the Port of Long Beach and Port of Los Angeles with funding from the CEC, US DOT, and Ports of Long Beach and Los Angeles [6]. **Motiv** won a grant from the CEC to continue commercialization of its all-electric powertrain [7]. Table 14 shows a summary of the new battery electric and fuel cell trucks producers and their public funding sources.

**Table 14. Battery- electric and fuel cell truck manufacturers and their public funding sources**

Company	Products	Public Funding Source
Transpower	Battery electric and fuel cell trucks	CEC, US DOE, Ports of Long Beach and Los Angeles, US EPA, SCAQMD
Odyne	Battery electric medium- and heavy-duty work trucks	CEC, US DOE, SCAQMD
Orange EV	Battery electric terminal trucks	CMAQ, CEC, US DOT, Ports of Long Beach and Los Angeles
Motiv	All-electric powertrain	CEC

Since the majority of companies producing battery-electric and fuel cell trucks are small and upstarts, they generally rely heavily on public funding to continue developing, manufacturing, and demonstrating these vehicles. Without these sources they would be unable to produce trucks for these markets.

New technologies benefit from small startup companies because they generally bring these technologies to the system integration and demonstration phase much quicker than larger OEMs. Large established companies will spend much more money and significantly longer time verifying and validating technologies before deciding to commercialize them. The smaller companies must demonstrate technologies sooner in order to stay in business. Volvo estimates that the demonstration phase (technology readiness level 5) may only represent 10% of the time and money necessary for an established OEM to fully commercialize a new product vehicle [8].

## 4.2 Advanced Truck Costs and Economics

### 4.2.1 Cost of advanced powertrain systems

Cost-effective improvements in conventional vehicle technologies such as aerodynamics, tire rolling resistance, engine efficiency and multi-speed transmissions, weight reduction, and electrified accessories can reduce fuel consumption and CO<sub>2</sub> emissions by up to 25%. To

achieve reductions significantly greater than 25% will require the utilization of advanced technologies such as all-electric and hybrid-electric powertrains, fuel cells, and alternative fuels. There have been several studies (see References [9], [10], and [11]) of medium- and heavy-duty trucks using these technologies as well as projection in the Phase 1 and 2 rule-making reports (i.e. References [12] and [13]) of the costs associated with them. A few major truck suppliers (ex. Volvo and Freightliner) have started development and demonstration of the advanced alternative truck technologies, but most of the development and demonstrations have been done by smaller, start-up companies, much of it under funding from CEC. The R&D to date has shown that alternative trucks can result in significant fuel savings if the trucks are placed in the right application. Currently, alternative trucks are in the early market stage and production volumes are too low to realize cost-effective prices. However, with costs decreasing over time, due to increased production volumes and improvements in design and manufacturing, alternative truck technologies are expected to be more competitive with conventional diesel trucks.

EPA/NHTSA have estimated the cost of hybrid-electric powertrain systems, all-electric drivetrains, and natural gas fuel technologies for HD pickups and vans, HD vocational vehicles and tractors in the proposed Phase 2 standards report. The incremental costs for alternative (low GHG) trucks vary significantly by technology and fuel type, as shown in Table 15. These estimates were not calculated from detailed cost analyses of the particular MD/HD vehicles, but were scaled up costs from detailed analyses of light-duty pickup trucks. Hence the size (kW or kWh) of the components in the hybrid powertrain are not given in the report. Each of the advanced technologies in the MD/HD vehicles is considered in the following sections.

**Table 15. Estimates of the incremental cost of a hybrid powertrain system, full electric drivetrain system, and alternative fuel system (2012\$)**

Drivetrain and Fuel	Vehicle Category	MY 2018	MY 2021	MY 2027
Strong Hybrid	HD Pickups and Vans		\$6,779	\$5,124
	Vocational LHD Vehicles		\$15,207	\$11,791
	Vocational MHD Vehicles		\$23,904	\$18,534
	Vocational HHD Vehicles		\$39,919	\$30,952
Mild Hybrid	HD Pickups and Vans		\$2,730	\$2,111
	Tractors	\$20,644	\$19,287	\$15,510
Full Electric	Vocational LHD & MHD Vehicles	\$58,600	\$55,216	\$49,920
	Day Cap Tractors	\$155,036	\$146,084	\$132,071
		<b>MY 2014</b>	<b>MY 2020</b>	<b>MY 2030</b>
Natural Gas	HHD Vehicles (Class 7 & 8)	\$70,000	\$65,000	\$60,000

#### **4.2.2 Hybrid-electric vehicles**

There are over 1,800 MD/HD hybrid vehicles operating in California. Hybrid drivetrain technologies present a significant opportunity for reducing fuel consumption and CO<sub>2</sub> emissions from vocational vehicles such as utility or bucket trucks, delivery vehicles, refuse haulers, and buses, as their duty cycles involve either a significant amount of stop-and-go activity or running the engine to operate a Power Take Off (PTO) unit. The EPA/NHTSA Phase 1 standards were not predicated on the adoption of hybrid powertrains in the vocational vehicle sector. In the proposed Phase 2 standards, several types of vocational vehicles were deemed to be well suited for hybrid powertrains, and could be purchased by early adopters of advanced technology. The cost estimates of strong hybrid powertrain systems for HD pickups and vans and vocational light, medium, and heavy HD vehicles and the mild hybrid systems for HD pickups and vans and tractors are listed in Table 15 in 2012 dollars for MY 2021 and MY 2027. As noted previously, the EPA/NHTSA cost estimates of hybrid powertrain technologies for HD pickups and vans, HD vocational vehicles, and tractors were obtained by scaling up the costs based on the ratio of the test weights for HD vehicles to the test weight of the 5,200 lbs LD reference trucks. The cost includes direct cost, indirect cost estimates and learning effects.

The proposed Phase 2 standards do not discuss the economics for adopting hybrid powertrain systems. However, the economics of strong hybrid HD pickups and vans and vocational vehicles can be evaluated using the inputs from the Phase 1 and Phase 2 standard studies. MY2017 HD pickups and vans and vocational HD vehicles with no hybridization are used as the baseline (Table 15). For strong hybrid powertrains, an average fuel consumption improvement of 24 percent over the urban cycle and the multi-purpose cycle is assumed in the analysis. The payload requirements for HD vocational trucks are listed in Table 17 and a payload of 3,100 lbs (1.55 tons) is used for HD pickups and vans. Since vehicle annual VMT changes with vehicle age (Table 18), the average vehicle VMTs over the first 5 years and 10 years of vehicle usage are used in the analysis to calculate annual fuel consumption. The fuel savings of hybrid vehicles and their reduced maintenance expense are used to pay down the incremental hybrid technology cost. The maintenance costs for hybrid-electric trucks are significantly lower than for conventional trucks [14]. This is shown in Figure 27, and is taken from Reference [14]. Calculations have been made of the breakeven fuel price for payback periods of 5 and 10 years and the payback periods for a diesel fuel price of \$4/gal. The results are shown in Table 19 for a maintenance cost difference of \$0.15/mile compared with the conventional vehicle. The large effect of the difference (\$/mi) in the maintenance cost of the hybrid truck relative to the conventional truck is shown in Figure 28. Without the reduced maintenance costs, the breakeven fuel prices for the strong hybrid trucks are higher than are those that are in fact likely to occur. Hence detailed knowledge of the maintenance costs for the various types of hybrid trucks and applications are needed to assess the economic viability of hybrid trucks.

**Table 16. MY 2017 Vocational Vehicle Standards (Reference [12])**

	<b>EPA Full Useful Life Emissions Standards (g CO<sub>2</sub>/ton-mile)</b>	<b>NHTSA Fuel Consumption Standards (gal/1,000 ton-mile)</b>
Light Heavy Class 2b-5	373	36.7
Medium Heavy Class 6-7	225	22.1
Heavy Heavy Class 8	222	21.8

**Table 17. Vocational Vehicle Tare Weight and Payload (Reference (12))**

<b>REGULATORY SUBCATEGORY</b>	<b>LIGHT HEAVY</b>	<b>MEDIUM HEAVY</b>	<b>HEAVY HEAVY</b>
Truck Tare Weight (lbs)	10,300	13,950	27,000
Payload (lbs)	5,700	11,200	15,000
Total Weight (lbs)	16,000	25,150	42,000



Table 18. Annual Vehicle Miles Traveled by Age (Reference (12))

VEHICLE AGE	REFERENCE			CONTROL		
	HD Pickups and Vans	Vocational Vehicles	Combination Tractors	HD Pickups and Vans	Vocational Vehicles	Combination Tractors
0	11,682	21,245	133,005	11,819	21,528	133,670
1	11,695	19,366	119,291	11,833	19,623	119,887
2	11,645	17,764	107,612	11,783	18,001	108,151
3	11,511	16,269	96,713	11,646	16,486	97,197
4	11,301	14,852	86,619	11,434	15,050	87,052
5	11,046	13,527	77,482	11,176	13,707	77,869
6	10,748	12,322	69,265	10,874	12,486	69,611
7	10,422	11,272	62,051	10,545	11,422	62,362
8	10,058	10,342	55,709	10,177	10,479	55,988
9	9,669	9,478	49,920	9,783	9,604	50,170
10	9,267	8,729	44,653	9,376	8,845	44,876

### Maintenance Cost per Mile

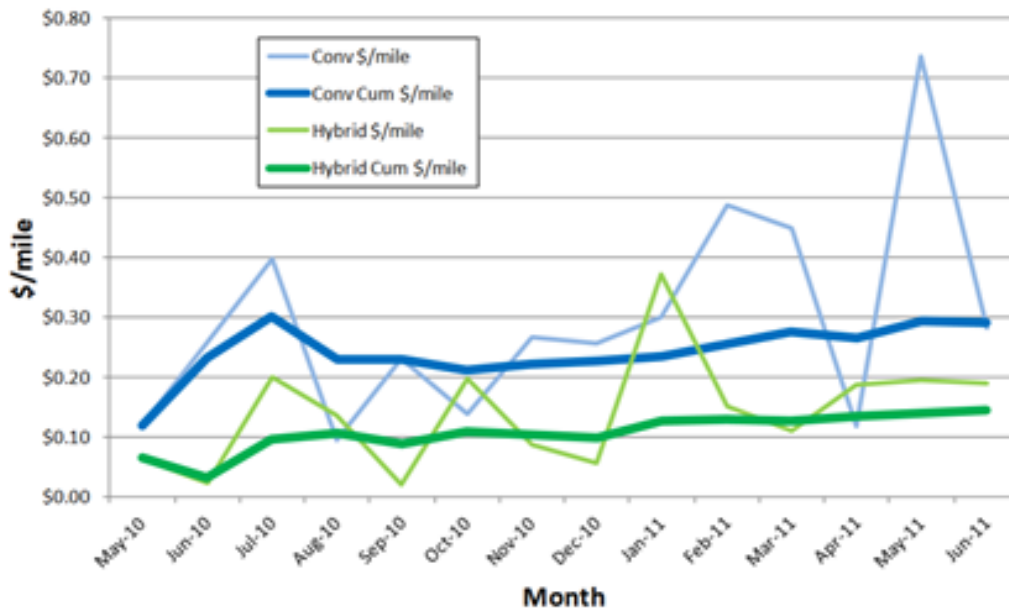

Figure 27. Hybrid vehicle maintenance cost per mile data from NREL (Reference (14))

**Table 19. Payback analyses**

Vehicle Subcategory	HD pickups/Vans	LHD	MHD	HHD
Vehicle Classification	Class 2b-3	Class 2b-5	Class 6-7	Class 8
Payload (lbs)	3,100	5,700	11,200	15,000
Average Annual VMT over the first 5 Years (miles)	11,600	17,900	17,900	17,900
Average Annual VMT over the first 10 Years (miles)	11,000	14,600	14,600	14,600
Fuel Consumption Standards for MY2017 with Zero Hybridization - Baseline (gal /1000 ton-mile)	36.7	36.7	22.1	21.8
Fuel Economy (mpg diesel)	9.6	9.6	8.1	6.1
Strong Hybrid System Cost at 2012\$ (dollars)	\$6,779	\$15,207	\$23,904	\$39,919
Projected Fuel Efficiency Improvement for strong hybrid over the Urban Cycle & Multi-Purpose Cycle	24%	24%	24%	24%
Considering fuel savings only				
Diesel price required for simple 5 years payback at 2012\$ (\$/gal)	10.65	8.4	11.15	14.1
Diesel price required for simple 10 years payback at 2012\$ (\$/gal)	5.61	5.13	6.82	8.62
Considering both Fuel and Maintenance Savings *				
Simple Breakeven Payback Period at \$4/gal diesel (year)	3	3.7	5.4	8.1
Simple Breakeven Payback Period at \$3/gal diesel (year)	3.2	4	6	9.1

\* Maintenance cost savings: \$0.15/mile

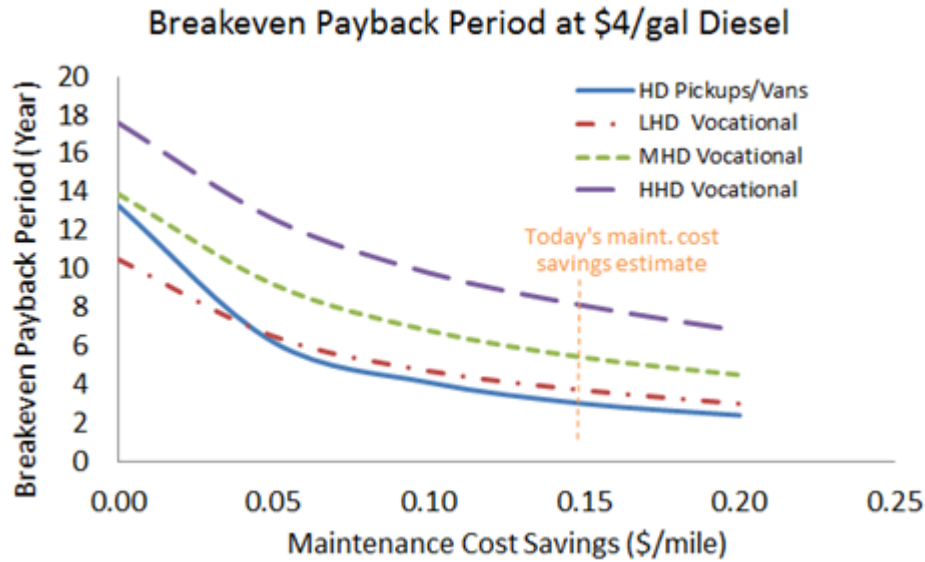

Figure 28. The effect of maintenance cost on the breakeven period

#### 4.2.3 Battery electric vehicles

At the present time, battery electric MD and HD vehicles are predominantly trucks and buses that operate on routes having frequent stops and starts, low average speed, and short daily ranges. The major issue restricting battery electric MD and HD vehicles to these applications are the high cost of the batteries needed to attain even a short range. Battery cost is a primary component in the incremental cost of battery electric trucks. In 2015 CARB estimated the battery costs are \$500 to \$700 per kWh. Table 20 shows the estimated incremental cost for typical battery-electric MD and HD trucks and buses (Reference [16]). Compared to a conventional engine-powered vehicle, the incremental costs are 60% - 200% of the baseline cost for MD & HD battery-electric trucks and 40% - 110% for battery-electric buses. In addition to these costs, there is the cost of the DC fast charging infrastructure (50-120 kW) for a charging station. The cost of a DC fast charging station is \$50K-\$100K.

**Table 20. Estimated incremental costs of battery-electric MD/HD (Reference [16])**

Vehicle Type	Current BEV Incremental Cost	Baseline Vehicle Costs	Current Incremental Cost (Percent of Baseline Costs)
Heavy-Duty (> 14,000 lbs. GVWR)	\$100,000 to \$200,000	\$100,000	100-200%
Medium-Duty (8,501 - 14,000 lbs. GVWR)	\$50,000 to \$90,000	\$80,000	60-110%
Transit Buses	\$315,000	\$485,000-\$525,000	60%
School Buses	\$60,000 to \$160,000	\$140,000	40-110%

As in the case of hybrid-electric vehicles, battery electric trucks and buses have lower operating and maintenance costs due to low electricity prices and less maintenance required. According to the 2013 CalHEAT study [17], maintenance costs are 3-10 cents per mile for electric delivery trucks compared to 12-15 cents per mile for conventional trucks in similar classes and applications. These operation and maintenance savings will help offset the incremental cost of the vehicle and the charging station. Present battery electric trucks and buses have 100-200 mile all-electric ranges. Assuming \$4/gal for diesel fuel, \$.10/kWh electricity cost, a battery cost of \$500/kWh, and incremental vehicle costs in Table 20, the payback periods for an electric medium-duty delivery truck (100 mile range) and electric transit bus (200 mile range), including the difference in energy and maintenance costs, are 4.6 and 12.4 years, respectively. Reducing battery costs and financial incentives would make electric MD/HD electric vehicles affordable.

Reducing the cost of battery packs and increasing the vehicle range would increase the markets for electric HD vehicles of various types. Based on the 2013 CalStart study [17], battery pack cost is expected to approach \$300/kWh by 2020 and \$200/kWh by 2030, which would reduce electric vehicle incremental costs to less than 50% of the baseline vehicle cost. In addition, more widespread deployment of vehicle charging stations would allow MD and HD trucks to perform as multi-task trucks, increasing daily range and reducing the payback period to less than 5 years. The effect of battery costs on the incremental cost of electric port drayage trucks is shown in Table 21.

**Table 21. Estimations of BEV Drayage Truck Costs 2012-2030 (Reference [16])**

Components	BEV (Year 2012)	BEV (Year 2020)	BEV (Year 2030)
Glider	\$79,000	\$79,000	\$79,000
350 kW motor	\$9,000	\$8,000	\$7,000
Power Electronics	\$12,000	\$10,000	\$8,000
350 kWh Battery System	\$210,000	\$111,000	\$74,000
<b>Total Vehicle Cost</b>	<b>\$308,000</b>	<b>\$208,000</b>	<b>\$169,000</b>
<b>Baseline Diesel Truck Cost</b>	<b>\$104,000</b>	<b>\$108,000</b>	<b>\$111,000</b>
<b>Incremental Cost</b>	<b>\$204,000</b>	<b>\$100,000</b>	<b>\$58,000</b>

(CALSTART, 2013)

#### **4.2.4 Natural gas fueled vehicles**

Natural gas, both conventional and renewable, is considered as a clean-burning alternative fuel for HD vehicles. Major truck manufacturers are now marketing Class 7 and 8 natural gas-fueled trucks because of the lower natural gas fuel prices compared with diesel on an energy equivalent basis. Currently, class 8 natural gas trucks cost about \$70,000 per truck more than diesel trucks. For long-haul trucks, the incremental cost of the truck can be offset by fuel savings. Therefore, high mileage long haul trucks are prime candidates for switching from diesel to natural gas as the fuel. Table 22 shows the payback analysis of natural gas trucks meeting the EPA/NHTSA standards. This analysis (see Reference [13]) was based on higher diesel fuel prices with a price difference of \$1.16, \$1.5, and \$2.82/gal DGE between diesel and natural gas price for 2014, 2020, and 2030, respectively. In the case of the present (2015), the lower diesel fuel prices (Figure 28) would result in much longer payback periods.

The natural gas fuel can be stored onboard the truck as a compressed gas (3600 psi) or as a cryogenic liquid. The infrastructure for dispensing the natural gas as a compressed gas is better developed than that for the cryogenic liquid. Further development of the natural gas refueling infrastructure is being funded by current CEC programs.

**Table 22. Payback analysis of natural gas trucks (Reference [13])**

	CASE 1 2014 DUEL FUELED	CASE 2 2014 HPDI	CASE 3 2020 HPDI	CASE 4 2030 HPDI
Miles per Year	120,000	120,000	120,000	120,000
Miles per Gallon	6.7	6.7	7.1	7.2
Incremental NG Truck Cost	55,000	70,000	65,000	60,000
Incremental NG Maintenance Cost per year	970	1613	1935	1935
Diesel Fuel Price (\$/gal)	3.80	3.80	4.16	5.65
Natural Gas Price (\$/gal DGE)	2.64	2.64	2.66	2.83
Diesel Fuel Cost per Year	68,263	56,886	70,608	94,167
Natural Gas Fuel Cost Per Year	60,062	43,978	50,614	53,810
Lower NG Efficiency (%)	5%	5%	5%	5%
Vehicle NG Use (%)	50%	95%	95%	95%
Simple Payback (years)	6.7	4.5	3.3	1.5
Discounted Payback (years)	9.1	5.5	3.7	1.6

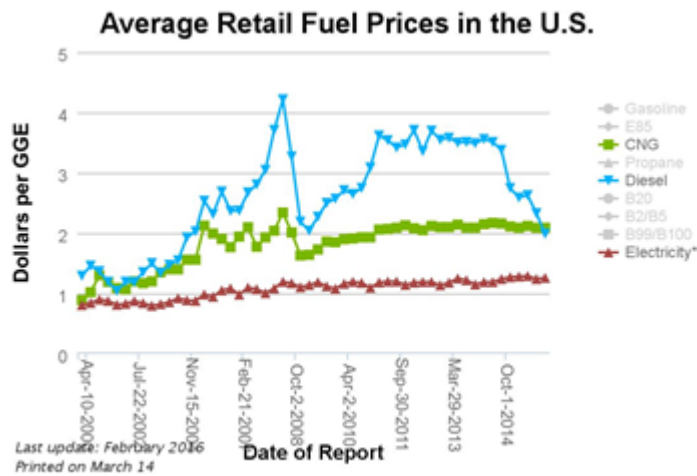

**Figure 29. Average fuel/energy prices (2010-2014)**

#### 4.2.5 Fuel Cell Trucks and Buses

The fuel cell trucks and buses have zero-emissions from the tailpipe. They can have moderate range for an affordable size hydrogen storage tank and fast refueling compared to the battery electric vehicles. Several hundred fuel cell electric buses have been deployed worldwide in small scale pilot projects. Over two dozen fuel cell buses have been demonstrated in the U.S. Fuel cell trucks are also being evaluated in the Port of Los Angeles for drayage operations, which feature short-distance freight movement such as conveying cargo containers from a port to a rail yard or warehouse. Fuel cell trucks have a potential range of up to 400 miles between hydrogen refueling and can save an estimated 6,000 gallons of diesel fuel per year [18].

Since hydrogen storage system gravimetric density and system volumetric density are low compared to storing diesel fuel, hydrogen storage tanks for MD/HD trucks are bulky, heavy, and presently expensive.

The infrastructure for refueling hydrogen vehicles is very limited at the present time. In the case of the fuel cell buses, the hydrogen storage and refueling are done at a terminal where the buses are stored overnight. In some cases, the hydrogen is produced at the same site. The public hydrogen infrastructure for light-duty vehicles is currently being built to support fuel cell passenger cars being marketed. That development is being funded by CEC and DOE grants and several automobile manufacturers.

At the present time, 95 percent of hydrogen is produced via steam methane reformation (SMR) at central plants. The hydrogen fuel cost is about \$8/kg. A UC Davis study [13] indicated that a fully loaded Class 8 fuel cell powered truck with a 450 kW fuel cell and a hydrogen tank storing 50 kg H<sub>2</sub> has a range of 200 miles before refueling. The incremental cost of the truck was estimated to be about \$100K. Simulations for various driving cycles indicated that the hydrogen fuel cell truck would improve the diesel equivalent fuel economy by 27-39% over the day drive, the short haul, and the long haul drive cycles. The analysis indicated the fuel cell powered truck could be cost competitive with a diesel fueled truck at VMT= 150,000 miles if the fuel cell cost was less than \$25/kW. This is close to the projected future cost (\$30-50/kW) of fuel cells for light-duty vehicles in mass production. Present costs for fuel cells in limited production are in excess of \$100/kW.

Actual operational data of AC Transit fuel cell electric buses [19] demonstrates that the performance of fuel cell transit buses has significantly improved in recent years. The vehicle prices have declined by 70%, maintenance costs decreased by 50%, and operating costs decreased by 30% (Table 23).

**Table 23. AC Transit fuel cell electric bus performance (Reference [19])**

Criteria	2011	2012	2013	2013-Diesel
Availability	63 %	56 %	82 %	76 % – 84 %
Maintenance Cost	\$ 1.51 / mi	\$ 1.31 / mi	\$ 0.67/mi	\$ 0.21 – 1.03 / mi
Fuel Cost	\$ 1.49 / mi	\$ 1.40 / mi	\$ 1.41 / mi	\$ 0.75 – 0.79 / mi
Operational Costs	\$ 3.01 / mi	\$ 2.71 / mi	\$ 2.08 / mi	\$ .97 – 1.82 / mi

- Bus prices have declined by 70%
- Maintenance costs decreased by 50%
- Operational costs decreased by 30%

#### 4.2.6 Comparison of advanced technology vehicles

The economics and fuel economy improvements for the various advanced technologies in medium- and heavy-duty trucks have been studied in Ref. [15-17]. The results of those studies are summarized in Table 24. In those studies, the powertrain and vehicle characteristics were described in detail including the vehicle range which has a significant effect on the incremental vehicle cost. Calculations were made using today's (2013) and future (2025-2030) technologies and projected component and vehicle costs. The future technologies are not dissimilar to those utilized in the "Super Truck" program. The breakeven fuel price in each case is that given in the units appropriate for that fuel or energy. For example, the breakeven cost of hydrogen is given in terms of \$/kgH<sub>2</sub> and the price of natural gas is given as \$/gge (gallon gasoline equivalent). The baseline vehicles are those using a diesel engine in today's or future vehicles. All fuel economy values are given in terms of dge (diesel gallon equivalent.) Note in Table 24 that the fuel economy improvements are modest for hybrid-electric powertrains and large for battery-electric and fuel cell vehicle technologies. The breakeven prices for the alternative fuels were calculated for a diesel fuel price of \$4/dge. This was the cost of diesel at the time the study referred to was performed. When the price of diesel is lower, the corresponding breakeven alternative fuel price would also be lower. The results in Table 24 indicate that the technology improvements and cost reductions expected in the future will make the advanced technologies more attractive economically and lead to large reductions in petroleum use and greenhouse gas emissions. In most cases, today's costs for the advanced vehicles will require financial incentives for the purchase of the vehicles.

**Table 24. Breakeven fuel prices for medium- and heavy-duty advanced vehicles (Ref. [16])**

Truck technology	Range	(mpg) <sub>dge</sub>	% fuel economy improvement	Incremental vehicle price increase \$	Breakeven fuel price
<b>Medium-duty truck</b>					
<b>Diesel HEV (1)</b>					
today (3) baseline 12.0 mpg		13.3	10.8	5770	>9.8\$/dge
Future (4) 25.1 mpg		30.9	23.1	1676	>3.4\$/dgel
<b>CNG-SI HEV</b>					
Today baseline 11.1 mpg	100 mi	11.4	2.7	8895	<2.63\$/ggel
Future					



Truck technology	Range	(mpg) <sub>dde</sub>	% fuel economy improvement	Incremental vehicle price increase \$	Breakeven fuel price
<b>23.9 mpg</b>	150 mi	26.9	12.5	3701	<2.30\$/dge
<b>Bat. Elec*</b>					
<b>today</b>	Range 50 mi	44.7		47,775	-----
<b>future</b>	Range 75 mi	75.1		9947	<.036\$/kWh
<b>Fuel cell (H<sub>2</sub>)*</b>					
<b>today</b>	Range 50 mi	30.7		14325	<1.3 \$/kgH <sub>2</sub>
<b>future</b>	Range 75 mi	51.0		1532	<6.6\$/kgH <sub>2</sub>
<b>Heavy-duty truck</b>					
<b>Diesel HEV (2)</b>					
<b>Today baseline 6.3 mpg</b>		6.8	7.9	24150	>3.3\$/dge
<b>Future Baseline 11.4 mpg</b>		12.8	12.3	7240	>2.5\$/dge
<b>CNG - Si HEV</b>					
<b>Today baseline 5.0 mpg</b>	400 mi	5.7	14.0	47750	<3.0 \$/gge
<b>Future 9.9 mpg</b>	500 mi	11.8	19.2	24370	<2.7 \$/dge
<b>Bat. Elec *</b>					
<b>today</b>	Range 150 mi	13.3		285750	-----
<b>future</b>	Range 150 mi	22.5		88640	<.0265 \$/kWh
<b>Fuel cell (H<sub>2</sub>)*</b>					
<b>today</b>	Range 150 mi	8.3		54425	<3.4 \$/kgH <sub>2</sub>
<b>future</b>	Range 150 mi	15.1		14141	<4.4\$/kgH <sub>2</sub>

(1) Daily driving cycle, (2) Highway driving cycle, (3) today 2013, (4) future 2025-2030

\* diesel fuel \$4/gal

### 4.3 Decision-making processes for truck purchases

Truck fleet managers purchase new vehicles as older trucks are retired or sold into secondary markets. When making purchase decisions, managers must consider a wide variety of factors, and the importance of each factor may vary depending on the fleet. Some of the critical factors are:

- Capital cost
- Operating cost
- Total cost of ownership
- Payback period
- Technology risk
- Vehicle range/Refueling time/Station availability
- Environmental perception
- Secondary markets
- Incentives/Subsidies

New technologies generally have higher capital costs at least until they can be produced in high volumes. The risk or uncertainty associated with these technologies and issues related to infrastructure can often be further barriers to adoption. The potential benefits of reduced operating cost, incentives or subsidies, and the value of enhanced environmental perception must counter the barriers in order for fleet managers to begin adopting these technologies.

#### Capital Cost

New technology capital costs can be significantly higher than the costs of present technologies. These costs will decrease over time as manufacturing processes improve and volume sales increase. Presently the cost for a battery packs large enough to give a reasonable range is high. Fuel cells and hydrogen storage also are expensive. Natural gas vehicles also have a price penalty, but they are closer to the cost of diesel trucks.

#### Operating Cost

The operating cost of a vehicle depends on the price of fuel, the vehicle miles traveled per year, and maintenance costs. Alternative fuels such as natural gas and electricity have lower fuel prices than diesel so advanced truck technologies can potentially have lower operating costs. The vehicle miles traveled varies considerably resulting in large differences in the benefit of lower fuel costs. Heavy-duty long haul trucks generally travel well over 100,000 miles per year, but drayage and day trucks travel only 30,000-50,000 miles per year. Lower fuel price will therefore benefit long haul trucks much more than other applications. Maintenance costs for new technologies can be higher or lower than conventional technology. Electric driveline vehicles can save considerably on brake wear, and battery electric and fuel cell vehicles have fewer moving parts that need maintenance.

## **Total cost of ownership**

The total cost of ownership is the purchase price plus the expenses incurred through its use, such as repairs, insurance and fuel.

## **Payback Period**

Fleet managers determine return on investment (ROI) based on the capital cost, operating costs, and payback period. Assuming higher capital costs, short payback periods require significant operating cost savings to produce positive ROIs. Fleet payback periods vary from roughly 1 year to 3 years. In some cases managers can extend the payback period to somewhat greater than 3 years if the new technology has strong potential benefits.

## **Technology Risk**

There are risks associated with new technologies due to future uncertainties. New technologies may be less reliable and require greater maintenance or have increased downtime. Many fleets sell vehicles into secondary markets. If those vehicles utilize advanced technologies that have higher costs and increased risk, secondary market fleets may be hesitant to purchase the vehicles. Some fleets retain their vehicle for the life of the truck and do not sell into secondary markets. Those fleets do not have to worry that other fleets will not purchase their used vehicles. Another concern is that the cost of alternative fuels may be higher than expected or the cost of diesel fuel may be lower than expected. Either situation would adversely affect the economics of the advanced technology.

## **Vehicle range/Refueling time/Station availability**

Fleet vehicles operate over well-defined driving routes that require a particular range before refueling. If a new technology vehicle has a reduced range, the vehicle may not be able to meet the demands of that route. If there are few fueling stations available and those stations are not close enough to vehicle routes, the driver may spend too much time driving to stations or, in the case of battery electric trucks, may spend too much time recharging. Time wasted refueling can be a huge potential barrier.

## **Environmental perception**

Fleets may receive significant benefits by operating vehicles with less of an environmental impact. Fleets can get preferential treatment from customers who desire a positive environmental image. Some companies will explicitly give contracts to fleets known to operate trucks with lower greenhouse gas and air quality emissions.

## **Incentives/Subsidies**

When a fleet manager looks at all the factors that impact purchase decisions, the potential benefits may not outweigh barriers such as purchase cost, technical risk, and fuel uncertainties. In that case incentives or subsidies for the new technology would be considered. If the incentive/subsidy is high enough, the ROI may become positive or at least close to positive. In that case, the benefits of the technology could push the fleet manager to purchase the new technology.

Fleets may vary significantly in how they assess the various purchase factors. Large fleets may not worry as much about risk since they can afford to have more vehicle downtime. Small fleets or owner operator fleets (fleets with one or a few trucks operated by the owner) may not be able to overcome downtime or problems with the technology. Larger fleets may directly purchase fueling stations where their trucks will refuel. Those stations can supply alternative fuels such that station availability is not an issue. Some fleets are more progressive valuing environmental perception more than other fleets. Very large fleets will often experiment with new technologies so they have experience with them. These fleets may purchase a significant number of vehicles and operate them in regular service to understand the problems or benefits better. Fleet purchases of 50-100 vehicles at a minimum are necessary for the fleets to properly evaluate the new technology over a variety of conditions.

All fleet purchases must meet minimum vehicle requirements. Any technology that falls short, no matter how large the potential benefits, will not be purchased. If a battery electric truck has a range that simply cannot meet the route requirements, the company will not purchase those vehicles. If weight constraints are exceeded due to the excessive weight of powertrain or fuel storage unit, the technology will not be considered. Companies wishing to sell into those markets must understand these constraints and make sure their vehicle technology meets them.

#### 4.4 References

- [1] TransPower, “Orders for TransPower Trucks and Tractors: TransPower Announces New Heavy-Duty Electric Vehicle Achievements,” March 26, 2015, available at <http://www.transpowerusa.com/press-releases/16-million-in-new-orders-for-transpower-trucks-and-tractors/>
- [2] TransPower, “TransPower Secures \$3.7 Million in Funding for Demonstration of Electric Drayage Trucks,” July 9, 2013, available at <http://www.transpowerusa.com/press-releases/transpower-secures-3-7-million-funding-demonstration-electric-drayage-trucks/>
- [3] [Odyne](http://www.odyne.com/aboutodyne/181.html), “Odyne Systems Participates in \$45.4 Million Contract for Deployment of Plug-in Hybrid Medium- and Heavy-Duty Trucks,” June 6, 2013, available at <http://www.odyne.com/aboutodyne/181.html>
- [4] Work Truck Magazine, “Odyne Awarded California Grant to Retrofit Trucks,” June 2, 2014; Available at <http://www.worktruckonline.com/channel/green-fleet/news/story/2014/06/odyne-award-california-grant-to-retrofit-trucks.aspx><http://www.worktruckonline.com/channel/green-fleet/news/story/2014/06/odyne-award-california-grant-to-retrofit-trucks.aspx>
- [5] [Green Car Congress](http://www.greencarcongress.com/2015/02/20150205-orange.html), “Orange EV Offering On-Road Electric Terminal Truck,” February 5, 2015; Available at <http://www.greencarcongress.com/2015/02/20150205-orange.html>
- [6] Saxton, Mike, and Marquez, Jesse, “California Sustainable Freight Action Plan Pilot Project Ideas,” Submission for Orange EV, November 30, 2015; Available at <http://www.arb.ca.gov/gmp/sfti/sfpp/sfpp-048b.pdf>
- [7] Motiv Power Systems, “Motiv Power Systems Wins \$8.1 Million and Opens Manufacturing Facility to Meet All-Electric Truck and Bus Demand,” May 27, 2015; Available at <http://www.prnewswire.com/news-releases/motiv-power-systems-wins-81-million-and-opens-manufacturing-facility-to-meet-all-electric-truck-and-bus-demand-300089217.html>
- [8] Dawn Fenton, “Volvo, Investment Considerations: Medium and Heavy Duty Truck technologies in California”, presentation at UC Davis STEPS Workshop, Assessment of Critical Barriers and Opportunities to Commercialize Medium and Heavy Duty Truck Technologies in CA, December 3, 2015.
- [9] Davis, S.C., Diegel, S.W., Boundy, R.G., 2013. 2012 Vehicle Technologies Market Report. US Department of Energy’s, Vehicle Technologies Office, Oak Ridge National Laboratory, Oak Ridge.
- [10] Hengbing Zhao, Andrew Burke, Marshall Miller, Analysis of Class 8 truck technologies for their fuel savings and economics, Transportation Research Part D: Transport and Environment, Volume 23, August 2013, Pages 55-63

- [11] Hengbing Zhao, Andrew Burke, Lin Zhu, Analysis of Class 8 Hybrid-Electric Truck Technologies Using Diesel, LNG, Electricity, and Hydrogen, as the Fuel for Various Applications, EVS27, Barcelona, Spain, November 17-20, 2013
- [12] EPA and NHTSA, Final Rulemaking to Establish Greenhouse Gas Emissions Standards and Fuel Efficiency Standards for Medium- and Heavy-Duty Engines and Vehicles - Regulatory Impact Analysis, EPA-420-R-11-901, August 2011
- [13] EPA and NHTSA, Proposed Rulemaking for Greenhouse Gas Emissions and Fuel Efficiency Standards for Medium- and Heavy-Duty Engines and Vehicles—Phase 2 Draft Regulatory Impact Analysis, EPA-420-D-15-900, June 2015
- [14] K. Walkowicz, M. Lammert, and P. Curran, Coca-Cola Refreshments Class 8 Diesel Electric Hybrid Tractor Evaluation: 13-Month Final Report, NREL/TP-5400-53502, August 2012
- [15] Burke, Andrew and Lin Zhu (2014) Analysis of Medium Duty Hybrid-Electric Truck Technologies using Electricity, Diesel, and CNG/LNG as the Fuel for Port and Delivery Applications. European Electric Vehicle Congress, Brussels, Belgium, December 3-5, 2014
- [16] Zhu, L., Fuel economy, emissions, and economics analysis of alternative fueled medium- and heavy-duty vehicles, M.S. thesis, University of California -davis, Transportation Technology and Policy, June 2014
- [17] CARB, Draft Technology Assessment: Medium- And Heavy- Duty Battery Electric Trucks And Buses, October 2015
- [18] CalHEAT, Battery Electric Parcel Delivery Truck Testing and Demonstration, PIER project report, California Energy Commission PIER Project Report Version 2.0, August 2013
- [19] [www.ucsusa.org](http://www.ucsusa.org), Truck Electrification Cutting Oil Consumption & Reducing Pollution, October 2012
- [20] CARB, Medium- and Heavy-Duty Fuel Cell Electric Vehicles – Technology Assessment, September 2014.

## **5. Solutions to promote market success for advanced (low GHG) trucks and buses**

### **5.1 Government policies, incentives, and engine and vehicle emission standards**

The reduction of greenhouse gas (GHG) emissions has been a high priority for the state of California since 2006 and, more recently, for the Federal government of the United States as well. These priorities have led to an extensive series of policies and regulations in both California and the US intended to reduce GHG emissions in the various sectors of their respective economies. Since the transportation sector is a large contributor to total GHG emissions, many of these policies, regulations, and incentives have dealt with vehicles, ranging from light-duty passenger cars to class 8, long-haul trucks. Below, several policy areas will be discussed with respect to how each can be used to promote the marketing of alternative (i.e. low GHG) trucks.

The policies of most significance to reducing greenhouse gas (GHG) emissions from vehicles are those which set engine emission standards and vehicle fuel economy standards for various types of engines and vehicles. Fuel economy standards (CAFÉ) for light-duty vehicles (passenger cars and small trucks) have been set by NHTSA since 1975 (beginning with a model year 1978 standard). While the early standards were established due to concerns with petroleum supply, the most recent CAFÉ standards, for 2017-2025, were set with a reduction of GHG emissions in mind. As discussed in Sec 3.1, NHTSA/DOE have begun to set fuel efficiency and CO<sub>2</sub> emission standards for engines and trucks of various weights and types. The Phase 1 standards (Tables 4 and 6) were finalized in 2011, while Phase 2 standards were proposed in 2015 and are currently out for comment by stakeholders. The standards for 2014-2027 must be satisfied by all manufacturers of engines and trucks sold in the United States. The Phase 1 and Phase 2 regulations will mandate that truck GHG emissions be reduced by 25-30% by 2027. As the new regulations are currently written, NHTSA/DOE analyses indicate that the regulations can be met with improvements in conventional technologies in a cost-effective way (i.e. with a payback periods of less than 3 years) without large scale introduction of advanced technologies, such as powertrain electrification and fuel cells. In this discussion of solutions to promote the marketing of advanced, MD/HD trucks, it is assumed that the Phase 1 and 2 standards, as proposed by NHTSA/DOE, will be in place, and that further solutions refer to the markets for advanced technology trucks and alternative fuels.

There could still be changes in the Phase 2 standards that would require some introduction of hybrid, battery electric, and/or fuel cell powered vehicles. As noted in Sec 4.2, the incremental vehicle costs to implement the advanced technologies will be significantly higher than for the conventional technologies; hence it seems likely that some cost incentives such as the California HVIP program, will be needed to promote the initial sales of vehicles using those advanced technologies. The structure of the potential incentives are discussed below. Beyond the initial costs of the vehicles, there is the problem of providing the refueling infrastructure for electricity, natural gas, and possibly hydrogen on a local, regional, and national basis, at prices

that make operation of the advanced vehicle profitable. Infrastructure will also be considered in a later section.

### **Engine emission standards**

Emissions standards for engines used in trucks have been in place for many years, but these standards referred to pollutants like CO, hydrocarbons, NO<sub>x</sub>, and particulate matter (PM), all of which influence air quality. The NHTSA/DOE engines standards are on fuel efficiency (gal fuel/100 bhp-hr) and CO<sub>2</sub> emissions (gm CO<sub>2</sub> /bhp-hr), and must be met in addition to the “air quality” pollutant standards. In fact, it seems likely that the new CO<sub>2</sub> engine standards in the future will have to be met along with a NO<sub>x</sub> standard that is more stringent than .2 NO<sub>x</sub>/bhp-hr.

The diesel engine fuel efficiency standards for 2014-2027 are summarized in Table 3. All engines used in medium and heavy-duty trucks will have to meet these standards, regardless of the remainder of the powertrain. It seems likely that, in future years, the engine fuel efficiencies will be increased to 50%. Improving the engine efficiency is, of course, the most direct way to improve vehicle efficiency and reduce CO<sub>2</sub> emissions; hence engine R&D should remain a high priority for funding.

### **CEC grant programs for powertrain and vehicle development**

The California Energy Commission (CEC), under ARFVTP funding, has supported a number of powertrain and vehicle development contractors that seek to develop low GHG emission vehicle technologies. In nearly all cases, the contracts are intended to develop advanced technologies which would enable medium- and heavy-duty vehicles to achieve fuel efficiency and GHG emissions significantly lower than the Phase 2 standards. These contracts will continue to be important, especially during the period when the large vehicle manufacturers are focused on providing vehicles for sale that meet the Phase 1 and 2 standards.

It is important that, in the work of the CEC contractors, careful attention is given to fuel efficiency and GHG emissions and that vehicle performance in that regard is measured as a benchmark for success of the program. Incremental cost of the vehicles is important in the eventual commercialization of the technologies, and so component selection and system complexity and control should include cost considerations. Cost comparisons of the new technologies with baseline vehicles are needed to assess their marketability. In this way, the CEC contracts will provide technologies and vehicles in support of the ARB efforts to move beyond the Phase 2 standards and to lower GHG emissions as quickly as possible.

### **Financial incentives**

The California HVIP program for financial incentives for hybrid-electric and Zero and Near Zero emission medium- and heavy-duty trucks and buses was discussed in Sec. 3.2. The continued success of the HVIP program is important to the early marketing of advanced, low GHG trucks and buses with fuel efficiency and emissions significantly lower than the Phase 2 standards.



Vehicles qualified for the HVIP program also offer potential markets for powertrains and vehicles developed in conjunction with the CEC grant programs when they move beyond the demonstration phase. That has already been the case for some CEC grant program contractors (Ex. EVI, Motiv).

### **Government purchases of advanced vehicles for their fleets**

Federal, State, and local governments in the United States have 1.2 million vehicles in their fleets and in 2014 registered 175,122 new vehicles of which only .03% were electric and 4% were hybrids. The California and the United States Federal governments issued executive orders in the last few years requiring that agencies purchase energy efficient, zero emission vehicles in the future. In the case of the Federal government, the requirement is to purchase 20% of those vehicles by 2020 and by 2025, electric or hydrogen fuel cell vehicles would have to account for 50% of the purchases. It seems reasonable for governments at all levels to support the marketing of advanced vehicles especially during the early phases of their introduction.

### **5.2 Role of fuel prices and alternative fuel support**

Combining the use of low carbon fuels, such as natural gas, hydrogen, and electricity, with advanced powertrain and vehicle technologies offers the most attractive approach to reducing both GHG emissions and those emissions that strongly influence air quality. Major challenges to the use of alternative fuels is the lack of infrastructure for the storage, distribution, and dispensing of the fuels. There are major current efforts in California to provide the refueling infrastructure for alternative fuels for light-duty vehicles, but less of a focus on refueling for medium- and heavy-duty vehicles, which require larger and faster transfer of the fuel/energy to the vehicles. For the regional MD and HD vehicles, the infrastructure can be provided by the fleet owner, but it is likely that that will require some financial incentives from California. Providing those incentives is important for the early commercialization of the alternative fuels, electricity and natural gas, in particular.

Fuel price is an important factor in the early commercialization of the advanced technologies. This includes the price of diesel fuel and gasoline as well as the price of electricity, natural gas, and hydrogen. Since the simplest way to determine the economic viability of a technology is to calculate the payback period in which the incremental vehicle cost is recovered via reduced fuel/energy costs, changes in the price of fuel/energy can have a large effect on attempts to market the advanced technologies. Since, for the most part, California has no control over the price of diesel fuel, gasoline, and natural gas, and very limited control over the price of electricity, it would be helpful if the effect of the changes in fuel/energy costs could be mitigated, to some extent, by tax policy, since these price changes can significantly impact the vehicle operating expenses of the fleet owners. This would give some certainty to the operating expenses expected by fleet owners as they invest in the advanced technologies.

# Appendix I. Agenda and Attendees for Dec. 3 workshop at UC Davis



## Assessment of Critical Barriers and Opportunities to Commercialize Medium and Heavy Duty Truck Technologies

in California



### Agenda & Attendees

December 3, 2015

8:45am - 5:00pm, with reception to follow

[The ARC \(Activities and Recreation Center\)](#) Ballroom, UC Davis

The [California Energy Commission \(CEC\)](#) and [UC Davis Institute of Transportation Studies \(ITS-Davis\)](#) will conduct joint workshops on December 2-3, 2015 with a goal to:

- Present and discuss insights on emerging technologies for medium and heavy duty trucks in California, progress achieved to date, critical barriers, and requirements needed to boost commercialization.

The workshops will be held at the CEC on Dec. 2, and at UC Davis on Dec. 3. This [Sustainable Transportation Energy Pathways \(STEPS\)](#) research project is generously funded by the CEC, through the [National Center for Sustainable Transportation](#).

8:45 – 9:00am	<b>Registration &amp; coffee</b>
9:00 – 9:10	<p><b>Welcome and introduction:</b> Project objectives, overview of the day</p> <ul style="list-style-type: none"> <li>• <i>Janea Scott</i>, Commissioner, California Energy Commission (4 min)</li> <li>• <i>Tim Olson</i>, Energy Resource Manager, CEC (4 min)</li> <li>• <i>Andrew Burke</i>, Research Engineer, ITS-Davis</li> <li>• <i>Paul Gruber</i>, STEPS Executive Director, ITS-Davis</li> </ul>

<p>9:10 – 10:30</p>	<p><b>Session 1: Present status of alternative truck technologies</b></p> <p>What is the state of technologies available today, and what can we expect in the near-term (2016-2018)? What are highlights and trends from recent technology developments, manufacturing stages, and sales?</p> <ul style="list-style-type: none"> <li>· Facilitator: <i>Bill Van Amburg</i>, Senior Vice President, CALSTART (5 min)</li> </ul> <p>Presentations:</p> <ul style="list-style-type: none"> <li>· Diesel technologies – engines and transmissions (10 min) <ul style="list-style-type: none"> <li>o <i>Tom Fulks</i>, West Coast Rep, Diesel Technology Forum</li> </ul> </li> <li>· Natural gas technologies – engines and transmissions (10 min) <ul style="list-style-type: none"> <li>o <i>John Reed</i>, CEO, North American Repower</li> </ul> </li> <li>· Electric and electric-hybrid technologies (10 min) <ul style="list-style-type: none"> <li>o <i>Erik White</i>, Chief, Mobile Source Control Division, ARB</li> </ul> </li> <li>· Fuel cells and hydrogen (10 min) <ul style="list-style-type: none"> <li>o <i>Nico Bouwkamp</i>, Technology Analyst, California Fuel Cell Partnership</li> </ul> </li> </ul> <p>Responses/Group Discussion</p> <ul style="list-style-type: none"> <li>· Natural gas – <i>Tim Carmichael</i>, President, California Natural Gas Vehicle Coalition (4 min)</li> <li>· DME – <i>Emmanuel Varenne</i>, Alt Fuels Program Manager, Volvo (6 min)</li> <li>· Electric/electric hybrid – <i>Andy Swanton</i>, Director, Business Development, BYD (4 min)</li> <li>· Fuel cells and hydrogen – <i>Rob Del Core</i>, Director, Fuel Cell Power Systems, Hydrogenics USA (4 min)</li> </ul>
<p>10:30 – 11:00</p>	<p><b>Session 2: Alternative vehicle successes</b></p> <p>The CEC and DOE make significant investments to help spur development of alternative truck technologies. What are some of the most notable successes in funding to date?</p> <p>Facilitator: Paul Gruber</p> <p>Presentations:</p> <ul style="list-style-type: none"> <li>· Summary of CEC MD/HD project successes (10 min) <ul style="list-style-type: none"> <li>o <i>Larry Rillera</i>, Air Pollution Specialist, CEC</li> </ul> </li> <li>· Summary of SuperTruck projects (10 min) <ul style="list-style-type: none"> <li>o <i>Alicia Birky</i>, Analysis Team Lead, Energetics Inc.</li> </ul> </li> </ul> <p>Quick Responses/Q&amp;A (10 min)</p>
<p>11:00 – 12:30</p>	<p><b>Session 3: Drivers for purchase of MD/HD truck technologies</b></p>

	<p>What are the overarching drivers for successful purchase of MD/HD technologies? Facilitator: Tim Olson</p> <p>Presentations:</p> <ul style="list-style-type: none"> <li>· California and Federal Standards for fuel economy, CO2, and NOx <ul style="list-style-type: none"> <li>o <i>Henry Hogo</i>, Assistant Deputy Executive Officer, South Coast AQMD (10 min)</li> <li>o <i>John Mikulin</i>, Environmental Protection Specialist, US EPA Region 9 (10 min)</li> </ul> </li> <li>· Investment considerations (12 min) <ul style="list-style-type: none"> <li>o <i>Dawn Fenton</i>, Director, Sustainability &amp; Public Affairs, Volvo Group North America</li> </ul> </li> <li>· Customer requirements for vehicle purchases <ul style="list-style-type: none"> <li>o <i>Mark Stevens</i>, Fleet Manager, City of Sacramento (5 min)</li> <li>o <i>Robert Stroud</i>, Chief, Office of Fleet and Asset Management, DGS (5 min)</li> </ul> </li> <li>· Infrastructure and fuel availability requirements <ul style="list-style-type: none"> <li>o <i>Mark Duvall</i>, Director, Director Energy Utilization, EPRI (5 min)</li> <li>o <i>Dean Taylor</i>, Principal Advisor, Transportation Electrification Division, Southern California Edison (5 min)</li> </ul> </li> </ul> <p>Responses/Group Discussion for Sessions 2 and 3</p> <ul style="list-style-type: none"> <li>· <i>Joseph Steinberger</i>, Acting Manager Strategic Incentives Division, Bay Area AQMD (4 min)</li> </ul>
12:30 – 1:30	Lunch
1:30 – 4:30	<p><b>Session 4: Barriers and solutions for future market successes</b></p> <p>With the aid of a moderator, the following topics will be discussed. In addition, stakeholders in the audience will contribute their ideas based on their experience in developing various MD/HD technologies.</p> <p>Facilitators: Tim Olson (Policy Interventions – 4 min), Paul Gruber</p> <ul style="list-style-type: none"> <li>a. Large MD/HD Component and truck manufacturers <ul style="list-style-type: none"> <li>o <i>Jim Castelaz</i>, CEO, Motiv Power Systems (5-8 min)</li> <li>o <i>Tom Hodek</i>, Director of New Product Development, Cummins Westport (5-8 min)</li> </ul> <p style="text-align: center;"><i>Discussion</i></p> </li> <li>b. Fleets using heavy duty long haul and medium duty trucks <ul style="list-style-type: none"> <li>o <i>Jon Leonard</i>, Senior Vice President, Gladstein, Neandross &amp; Associates (5-8 min)</li> <li>o <i>Ryan Kenny</i>, Senior Policy and Regulatory Advisor, Clean Energy (5-8 min)</li> </ul> <p style="text-align: center;"><i>Discussion</i></p> </li> </ul>

	<p>c. Battery electric road strategies and drayage port truck developments</p> <ul style="list-style-type: none"> <li>o <i>Patrik Akerman</i>, Business Developer eHighway, Siemens (5-8 min)</li> <li>o <i>Joshua Goldman</i>, VP Business Development, TransPower (5-8 min)</li> </ul> <p><i>Discussion</i></p> <p>d. Vocational platforms – transit, delivery, school buses, refuse trucks, off-road</p> <ul style="list-style-type: none"> <li>o <i>Ryan Popple</i>, CEO, Proterra (5 min)</li> <li>o <i>Chris Peeples</i>, At-Large Director/President, Alameda-Contra Costa Transit District (5 min)</li> <li>o <i>John Landherr</i>, CEO, A-Z Bus Sales (5 min)</li> <li>o <i>Chuck White</i>, Waste Management (5 min)</li> <li>o <i>Marshall Miller</i>, Researcher, ITS-Davis (5 min)</li> </ul> <p><i>Discussion</i></p> <p>e. Government policies and standards</p> <ul style="list-style-type: none"> <li>o <i>Ryan Schuchard</i>, Policy Director, CALSTART (5 min)</li> <li>o <i>Bill Magavern</i>, Coalition for Clean Air (5 min)</li> </ul> <p><i>Discussion</i></p>
4:30 – 5:00	<b>Wrap-up and next steps</b>
5:00 – 7:00	<b>Reception at City Hall Tavern - Appetizers provided</b> 226 F St, Davis, CA 95616

## Sustainable Transportation Energy Pathways Program (STEPS)

[www.steps.ucdavis.edu](http://www.steps.ucdavis.edu)

STEPS is the major multidisciplinary research consortium within the Institute of Transportation Studies at the University of California, Davis. The consortium is comprised of 40+ PhD-level faculty and researchers and graduate students from UC Davis, 25+ industry and governmental partners, and 20+ outside expert organizations. Our mission encompasses:

- **Research:** generate new insights and tools to understand the transitions to a sustainable transportation energy future for California, the US and the world,
- **Outreach:** disseminate valued knowledge and tools to industry, government, the environmental NGO community, and the general public to enhance societal, investment, and policy decision making,
- **Education:** train the next generation of transportation and energy leaders and experts.

The STEPS 2015-2018 program is generously supported by these sponsors:

- Auto: BMW, Cummins, Daimler, Ford, Fiat Chrysler, GM, Honda, Renault, Toyota, Volkswagen
- Energy: Aramco, Centre for High Technology (India), Chevron, Shell, San Diego Gas & Electric/SoCal Gas Co., Sinopec
- Government: California Air Resources Board, California Energy Commission, Caltrans, South Coast AQMD, U.S. DOE, U.S. DOT, U.S. EPA

Our program areas and overarching research questions are:

- **Initiating Transitions 2015-2030:** What is required for early alternative fuel/vehicle transitions to succeed?
- **The Future of the Fuels and the Oil & Gas Industry:** How will changing geopolitical landscapes and disruptive technology in the oil and gas and clean technology industry impact future business models and the competition of fuels?
- **Global Urban Sustainable Transport (GUSTo):** How will a rapidly urbanizing world affect demand for transport and energy? How can we transition to sustainable transportation in a rapidly urbanizing world with ever-growing need for mobility?
- **Modeling Analysis, Verification, Regulatory and International Comparisons (MAVRIC):** What do improved and cross-compared economic/environmental/ transportation/energy models tell us about the future of sustainable transportation?

[What is the Sustainable Transportation Energy Pathways program?](#)



[Why sponsors value the UC Davis STEPS program:](#)



Comments and responses for this workshop, and STEPS program inquiries:

Paul Gruber, STEPS Executive Director, [pwgruber@ucdavis.edu](mailto:pwgruber@ucdavis.edu), (530) 752-1934

## Appendix II. Questions for December 3, 2015 Workshop

### Maximizing Commercialization of Non- Petroleum Medium and Heavy Duty Vehicle

- What are the prospects to maintain and grow market share for each of the petroleum and non-petroleum truck and bus options between now and 2020 and 2030? Where will growth occur in market subsectors, vocation/drive cycle, engine size?
- What attributes make each engine/vehicle technology option compelling for individual vehicle and fleet owners to buy? How will this be affordable as a total cost option for individual vehicle and fleet owners?
- Under what conditions and circumstances will major truck and bus OEMs and component manufacturers embrace new technology such as all electric, natural gas, hydrogen and renewable fueled trucks and buses? What is the role of start up manufacturers and technology innovators?
- How will medium and heavy duty engine and technology options comply with future regulations that require zero or near zero tailpipe emissions and low carbon intensity fuels, but still maintain the competitiveness of goods movement and agri-business industries and affordable transit?
- Is there a role for electric and natural gas utilities to make rate-based investments in infrastructure or vehicles to support the growth of non-petroleum vehicle options?
- Are existing government laws, policies, regulations and incentives focuses to achieve climate change goals? Should new initiatives be enacted or existing programs re-configured to increase effectiveness in achieving policy goals?

## Appendix III. Attendees of Dec. 3 workshop

### Attendees at UC Davis, “Assessment of Critical Barriers and Opportunities to Commercialize Medium and Heavy Duty Truck Technologies in California”

First	Last	Title	Organization
McKinley	Addy	Vice President	AdTra
John	Landherr	CEO	A-Z Bus Sales
Larry	Fromm	VP, Strategy and Business Development	Achates Power
Joe	Callaway	Senior Manager	Alameda-Contra Costa Transit District
H. E. Christian (Chris)	Peeples	At-Large Director / President	Alameda-Contra Costa Transit District
Peter	Ward	Principal	Alternative Fuels Advocates, LLC
Joseph	Steinberger	Acting Manager, Strategic Incentives Division	Bay Area Air Quality Management District
Jim	Boyd	Owner	Boyd Consulting
Nate	Springer	Manager	BSR
Andy	Swanton	Director, Business Development	BYD
Tim	Carmichael	President	CA NGV Coalition
Nico	Bouwkamp	Technology Analyst	CaFCP
Marijke	Bekken	Staff Air Pollution Specialist	California Air Resources Board
Joe	Calavita	Staff APS	California Air Resources Board
Mike	Carter	Assist. Division Chief	California Air Resources Board
John	Gruszecki	SAPS	California Air Resources Board
Jennifer	Lee	Air Pollution Specialist	California Air Resources Board
Robert	Nguyen	Staff Air Pollution Specialist	California Air Resources Board
Mike	Sutherland	Supervisor	California Air Resources Board



<b>First</b>	<b>Last</b>	<b>Title</b>	<b>Organization</b>
Erik	White	Chief, Mobile Source Control Division	California Air Resources Board
Hannah	Goldsmith	Project Manager	California Electric Transportation Coalition
Eileen	Wenger Tutt	Executive Director	California Electric Transportation Coalition
Rhetta	DeMesa	Advisor to Commissioner Scott	California Energy Commission
Samuel	Lerman	Air Resources Engineer	California Energy Commission
Darren	Nguyen	Automotive Equipment Standards Engineer	California Energy Commission
Tim	Olson	Energy Resource Manager	California Energy Commission
Matthew	Ong	Air Pollution Specialist	California Energy Commission
Marc	Perry	Energy Analyst	California Energy Commission
Larry	Rillera	Air Pollution Specialist	California Energy Commission
Janea	Scott	Commissioner	California Energy Commission
Courtney	Smith	Advisor to Commissioner Scott	California Energy Commission
Eric	VanWinkle	Associate Energy Specialist	California Energy Commission
Jerry	Wiens	Retired Annuitant	California Energy Commission
Lin	Zhu	Air Pollution Specialist	California Energy Commission
Ryan	Schuchard	Policy Director	CALSTART
Bill	Van Amburg	Senior Vice President	CALSTART
John	Shears	Research Coordinator	CEERT (The Center for Energy Efficiency and Renewable Technologies)
Gary	Cox	Chemist	Cenergy Solutions
Gary	Fanger	COO	Cenergy Solutions
Michael	Maxey	VP of Business Development	Cenergy Solutions
Jaimie	Levin	Director of West Coast Office	Center for Transportation and the Environment
Aaron	Schneider	Account Executive	ChargePoint, Inc.

<b>First</b>	<b>Last</b>	<b>Title</b>	<b>Organization</b>
Mark	Stevens	Fleet Manager	City of Sacramento
Ryan	Kenny	Senior Policy and Regulatory Advisor	Clean Energy
Shrayas	Jatkar	Policy Associate	Coalition for Clean Air
Bill	Magavern	Policy Director	Coalition for Clean Air
Ryne	Shetterly	ZEPS Sales Manager	Complete Coach Works
Tom	Hodek	Director of New Product Development	Cummins Westport
Tom	Fulks	West Coast Rep	Diesel Technology Forum
Joerg	Ferchau	CEO	Efficient Drivetrains.com
Alicia	Birky	Analysis Team Lead	Energetics Incorporated
Mark	Duvall	Director, Energy Utilization	EPRI
Jon	Leonard	Senior Vice President	Gladstein, Neandross & Associates
Shawn	Garvey	CEO	Grant Farm
Rob	Del Core	Director, Fuel Cell Power Systems	Hydrogenics USA
Hanjiro	Ambrose	Graduate Student Researcher	ITS-Davis
Beth	Bourne	STEPS Assistant Program Manager	ITS-Davis
Andy	Burke	Researcher	ITS-Davis
Rosa	Dominguez-Faus	Postdoctoral fellow	ITS-Davis
Paul	Gruber	STEPS Exec Dir	ITS-Davis
Raphael	Isaac	Graduate Student Researcher	ITS-Davis
Jeff	Kessler	Graduate student researcher	ITS-Davis
Guozhen	Li	Graduate Student Researcher	ITS-Davis
Marshall	Miller	Senior Development Engineer	ITS-Davis
Hengbing	Zhao	Researcher	ITS-Davis
Matthew	van Steenwyk	Managing Director	Longbow Tech Ventures

<b>First</b>	<b>Last</b>	<b>Title</b>	<b>Organization</b>
Michael	Coates	Principal	Mightycomm representing Volvo Group NA
Jim	Castelaz	CEO	Motiv Power Systems
Urvi	Nagrani	Marketing Manager	Motiv Power Systems
Kevin	Walkowicz	Manager - Simulation, Testing and Integration	National Renewable Energy Lab (NREL)
John	Reed	CEO	North American Repower
Zhenhong	Lin	Senior R&D Staff	Oak Ridge National Lab
Dan	Goodwin	Director of Corporate Affairs	Oberon Fuels
Robert	Stroud	Office Chief	Office of Fleet and Asset Management
Frank	Ramirez	Senior Permit Specialist	Office of Governor Edmund G. Brown Jr.
Quincy	Vien	Executive Fellow	Office of Governor Edmund G. Brown Jr., (GO-Biz)
F Kent	Leacock	Director Government Relations	Proterra
Ryan	Popple	CEO	Proterra
Evan	Williams	President	RePowered NGV Alliance LLC
Nathan	Bruner	Clean Transportation Business Development Manager	SDG&E
Patrik	Akerman	Business Developer eHighway	Siemens AG
Henry	Hogo	Assistant Deputy Executive Officer	South Coast Air Quality Management District
Dean	Taylor	Principal Advisor, Transportation Electrification Division Southern California Edison	Southern California Edison
Ronald	Kent	Technology Development Manager	Southern California Gas Co.
Cherif	Youssef	Technology Development Manager	Southern California Gas Co.
Ben	Sharpe	Senior Researcher	The International Council on Clean Transportation

<b>First</b>	<b>Last</b>	<b>Title</b>	<b>Organization</b>
Joshua	Goldman	VP, Business Development	TransPower
Ping	Li	CTO	Turboroto inc
Adam	Schultz	Manager	UC Davis Energy Institute
Laura	Podolsky	Policy Director	UC Davis, NCST
Jacques	Franco	Science & Policy Fellow	UC Davis Policy Institute
Alejandra	Cervantes	Graduate Student Researcher	UC Irvine, Advance Power and Energy Program
Jimmy	O'Dea	Vehicles Analyst, Clean Vehicles Program	Union of Concerned Scientists
Dale	Morin	Automotive Engineering Environmental Manager	UPS
Ben	Machol	Mgr, Clean Energy and Climate Change Office	US EPA, Region 9
John	Mikulin	Regional Lead, EV Deployment	US EPA, Region 9
Abas	Goodarzi	President	US Hybrid Corporation
Dawn	Fenton	Director, Sustainability & Public Affairs	Volvo Group North America
Sam	McLaughlin	Research Manager	Volvo Group
Emmanuel	Varenne	Alt Fuels Program Manager	Volvo
Jim	Antone	Air Quality Planner	Yolo-Solano AQMD

# Assessment of Critical Barriers and Opportunities for Plug-in Electric Vehicle Commercialization in California: Infrastructure for Light Duty Vehicles, Freight Movement, and Transit Buses and Port Vehicles

June 2016

A Workshop Report from the National Center  
for Sustainable Transportation

Andrew Burke (co-PI), University of California, Davis  
Amy Myers Jaffe (co-PI), University of California, Davis  
Lew Fulton, University of California, Davis  
Rosa Dominguez-Faus, University of California, Davis  
Marshall Miller, University of California, Davis  
Hengbing Zhao, University of California, Davis  
Guozhen Li, University of California, Davis  
Raphael Isaac, University of California, Davis  
Paul Gruber, University of California, Davis



National Center  
for Sustainable  
Transportation

**UCDAVIS**

**SUSTAINABLE TRANSPORTATION ENERGY PATHWAYS**

*of the Institute of Transportation Studies*

## **About the National Center for Sustainable Transportation**

The National Center for Sustainable Transportation is a consortium of leading universities committed to advancing an environmentally sustainable transportation system through cutting-edge research, direct policy engagement, and education of our future leaders. Consortium members include: University of California, Davis; University of California, Riverside; University of Southern California; California State University, Long Beach; Georgia Institute of Technology; and University of Vermont. More information can be found at: [ncst.ucdavis.edu](http://ncst.ucdavis.edu).

## **U.S. Department of Transportation (USDOT) Disclaimer**

The contents of this report reflect the views of the authors, who are responsible for the facts and the accuracy of the information presented herein. This document is disseminated under the sponsorship of the United States Department of Transportation's University Transportation Centers program, in the interest of information exchange. The U.S. Government assumes no liability for the contents or use thereof.

## **UC Davis Disclaimer**

The primary purpose of this report is to summarize insights from the April 26, 2016 workshop. Therefore, the views and recommendations expressed by workshop participants, and detailed in this report, do not necessarily reflect the views of the UC Davis research team.

## **California Energy Commission Disclaimer**

This report was prepared as the result of work sponsored by the California Energy Commission. It does not necessarily represent the views of the Energy Commission, its employees or the State of California. The Energy Commission, the State of California, its employees, contractors and subcontractors make no warrant, express or implied, and assume no legal liability for the information in this report; nor does any party represent that the uses of this information will not infringe upon privately owned rights. This report has not been approved or disapproved by the California Energy Commission nor has the California Energy Commission passed upon the accuracy or adequacy of the information in this report.

## **Acknowledgments**

This study was funded by a grant from the National Center for Sustainable Transportation (NCST), supported by USDOT through the University Transportation Centers program. The authors would like to thank the NCST and USDOT for their support of university-based research in transportation, and especially for the funding provided in support of this project.

# **Assessment of Critical Barriers and Opportunities for Plug-in Electric Vehicle Commercialization in California:**

## **Infrastructure for Light Duty Vehicles, Freight Movement, and Transit Buses and Port Vehicles**

**Report for the California Energy Commission Workshop, “Critical Barriers and Opportunities for PEV Commercialization in California: Infrastructure for Light-Duty Vehicles, Freight, and People Movement,” – April 26, 2016 at UC Davis**

---

A National Center for Sustainable Transportation Workshop Report

June 2016

**Sustainable Transportation Energy Pathways Program, Institute of Transportation Studies,  
University of California, Davis**

Andrew Burke (co-PI)

Amy Myers Jaffe (co-PI)

Lew Fulton,

Rosa Dominguez-Faus

Marshall Miller

Hengbing Zhao

Guozhen Li

Raphael Isaac

Paul Gruber

[page left intentionally blank]



## TABLE OF CONTENTS

Executive Summary .....	1
Purpose of the Workshop .....	3
Part I: Infrastructure for light-duty vehicles .....	4
1.1 Present status of the charging network in California in 2015.....	4
1.2 Technologies for battery charging .....	6
1.3 Role of the utilities in providing charging infrastructure .....	18
1.4 Charging infrastructure for 1.5 million PEVs by 2025 .....	19
1.5 Role of Federal, State, and regional government policies and incentives.....	21
1.6 Present and projected costs of charging stations for light-duty PEVs .....	21
1.7 Ways of reducing cost and inconvenience of charging to purchasers of PEVs.....	23
References for Part I.....	26
Part II: Infrastructure for commercial PEVs and transit buses .....	29
2.1 Electrification truck markets and technologies for MD/HD vehicles (HBZ/AFB) .....	29
2.2 MD/HD PEV vehicles in California and the United States—present and future.....	30
2.3 MD/HD charging infrastructure technologies and facilities .....	31
2.4 Transit bus charging facilities including ultra-fast and wireless charging.....	32
2.5 Costs of MD/HD charging facilities .....	33
2.6 Future requirements for MD/HD charging (buses, Ports, warehouses, etc.) .....	35
2.7 Ways of reducing the cost of the charging for MD/HD applications .....	36
References for Part II .....	38
Appendix I. Agenda and Attendees for April 26, 2016 workshop at UC Davis .....	41
Appendix II. Questions for April 26, 2016 Workshop.....	46
Appendix III. Attendees of April 26 workshop.....	50

# Executive Summary

This report summarizes the status of the infrastructure for charging electric vehicles and its commercialization. It discusses insights from the April 26 workshop at UC Davis, “Critical Barriers and Opportunities for PEV Commercialization in California Infrastructure for Light-Duty Vehicles, Freight, and People Movement,” in which over 130 stakeholders from industry, government and academia participated. The workshop highlighted critical barriers to the commercialization and recommended actions to maximize and accelerate the commercialization. Part I of the report is concerned with the infrastructure for light-duty plug-in electric vehicles. Part II is concerned with the infrastructure for medium-duty and heavy-duty vehicles.

## Part I: Infrastructure for light-duty electric vehicles

At the present time (April 2016), there are about 200,000 PEVs on the road in California and about 20,000 non-residential charging stations available to provide battery charging for them. The California ZEV Action Plan (2015) from the Governor’s Office has set goals of 1 million PEVs by 2020 and 1.5 million PEVs by 2025. This will require about 200,000 non-residential charging stations by 2020 and about 300,000 stations by 2025. These charging stations must be placed so that PEV owners who do not live in single-family dwellings have convenient access to them. In addition, about 10,000 fast charging points must be built along the major highways in California so that PEVs can be used for inter-city travel. To date many of the charging stations have been built with funding from CEC and CARB, but in the future the major funding for the large expansion of charging stations needed will likely come from the investor-owned electric utilities who have shown a serious interest in providing infrastructure for electrification of transportation. It is critical that the CPUC formulate in the near future an acceptable approach for the involvement of the utilities in large infrastructure projects. Auto manufacturers could become involved in building infrastructure like Tesla, but that seems unlikely. Both the PEV and battery charger technologies that meet the car buying public’s needs are available at decreasing costs as sales volumes increase. Hence a major factor in maintaining increasing sales of PEVs will likely be the timely building of the battery charging infrastructure needed by the new PEV owners. The cost of the infrastructure seems manageable being in the range of \$100-\$200 million per year between now and 2025. At the present time, the business case for installing and operating charging stations is difficult, but it will significantly improve as the numbers of electric cars on the road continues to increase.

## Part II: Infrastructure for medium-and heavy-duty electric vehicles

At the present time there are less than 500 MD/HD electric vehicles on the road in California and the charging infrastructures for those vehicles have been designed and built specifically for them. Medium-duty electric delivery trucks/vans represent the largest number of MD/HD electric vehicles on the road and charging of their batteries can be done using available Level 2 chargers. Charging the batteries of transit buses and other HD vehicles requires special equipment due to the size (kWh) and high voltage of their battery packs. In the case of transit

buses, the batteries can be slow charged (charging times of 6-8 hours) at the bus garages using special Level 3 chargers or fast charged (in less than 5 minutes) enroute using overhead charging units with which the buses are docked at selected bus stops. This latter approach requires high power (500-600 kW) and is used for Proterra buses by several transit agencies in California. Demonstrations of several heavy-duty class 8 electric trucks by TransPower utilize the motor inverter electronics on board the vehicle for charging their large (200 kWh) battery packs. This requires the availability of a 240V or 480V 3-Phase, high power (at least 70 kW) electrical service for the battery charging.

The direct-connection technology for charging batteries in MD/HD electric vehicles appears to be well-developed and commercially available in the United States, Europe, and Japan. At the present time, high voltage, high power charging stations are expensive primarily because the products have not been standardized both because sales volumes are low and standards for both connectors/docking units and interface protocols have not yet been established. Meetings are currently underway world-wide to establish the needed standards. Development of high power wireless charging technology is presently underway for HD electric vehicles. Deployment/demonstration of the wireless technology has only begun.

In most cases, the charging facilities for MD/HD electric vehicles will be provided by the vehicle operators in collaboration with the local electrical utilities. The business case for the charging stations should be reasonably attractive because they can be optimally sized for the fleet to be charged. For transit buses, funding for charging facilities is available as part of FTA grants for zero emissions vehicles. For demonstration projects, funding for small fleets and/or single vehicles is available in California with HVIP and CEC grants.

## Purpose of the Workshop

Both the United States and California have made commitments to achieve an 80% reduction in energy-related greenhouse gases (GHGs) from 1990 levels by 2050 in order to help stabilize atmospheric concentrations of GHGs. According to various analyses focused on achieving these GHG targets, transportation must play a large role in GHG mitigation through vehicle efficiency, advanced vehicle technologies, low-carbon fuel switching, and travel demand management. Low-carbon fuels such as hydrogen, natural gas, biofuels, and electricity are necessary elements of a sustainable transportation portfolio in most world regions, including California. In very optimistic low-carbon fuel mix scenarios developed by UC Davis, the California Air Resources Board, and others, use of these alternative fuels would need to grow considerably and, by 2050, be displacing on-road petroleum-based transportation fuels by approximately 80-90% in order for GHG goals to be met by 2050 (Yang, 2015). In 2015, Governor Brown of California set a target to reduce on-road petroleum usage in 2030 by up to 50%.

The Sustainable Transportation Energy Pathways (STEPS) team at the UC Davis Institute of Transportation Studies (ITS-Davis) and the California Energy Commission (CEC) conducted joint workshops on April 25 and 26, 2016 to seek and discuss insights on the growth and potential of plug-in electric vehicle (PEV) infrastructure deployments in California, including progress achieved to date, critical barriers, and strategies and policies needed to boost commercialization. The workshops were held at the CEC on April 25, 2016 and at UC Davis on April 26, 2016.

This document summarizes recent UC Davis research on the status of PEV infrastructure and its commercialization and discusses insights from the April 26 workshop at UC Davis, “Critical Barriers and Opportunities for PEV Commercialization in California Infrastructure for Light-Duty Vehicles, Freight, and People Movement,” in which over 130 stakeholders from industry, government and academia discussed the status of PEV infrastructure in California, highlighted critical barriers to commercialization, and recommended actions to maximize and accelerate commercialization. (Appendices I, II, and III list the agenda, key questions, and stakeholders who attended this workshop. The STEPS website page (<http://steps.ucdavis.edu/research/projects/initiating-transitions-2015-2030/steps-workshop-commercialization-of-md-and-hd-truck-technologies-in-ca/>) for this event lists these items as well as presentations.)

The April 26<sup>th</sup> workshop was the third in a series of three workshops, funded by the CEC and through the National Center for Sustainable Transportation, aimed at assessing critical barriers to commercialization for alternative fuel and vehicles technologies in California. The objective of this CEC-funded program is to “identify environmentally and economically promising alternative fuel and vehicle emerging technologies, and to identify and evaluate the critical business and policy barriers blocking their widespread adoption in the state and actionable solutions to overcome those barriers. Through this subtask we seek to analyze the broad range of commercial barriers and identify strategies to increase the adoption and rapid scale-up of emerging technologies, fuels and fueling infrastructure that will help the state achieve its

AB118 targets and goals for air quality and greenhouse gas emissions” (excerpted from UC Davis Statement of Work, CEC Agreement ARV-13-020).

The third workshop in this series was on April 26, 2016 at UC Davis, and focused on commercialization and deployment of plug-in electric vehicle infrastructure in California for light duty vehicles, freight, and transit. This coincided with an April 25 merit review public workshop conducted at the CEC on the same topic.

## **Part I: Infrastructure for light-duty vehicles**

This part of the report will focus on the status of private and public charging for plug-in, light duty electric vehicles in California and the United States in 2015 and how that status has changed in recent years. The primary focus is on battery powered electric passenger vehicles (BEVs), not plug-in hybrid vehicles (PHEVs), because the long term goal of a California and the nationwide network of chargers is to permit BEVs to be used as all-purposed vehicles for local, regional, and intercity transportation by all car owners regardless of where they live (single homes or apartments). This would permit the mass marketing of BEVs. The same charger network would permit owners of PHEVs to maximize the fraction of their miles driven on electricity and thus minimize the gasoline used.

Being able to refuel as needed is critical for the reliable operation of any vehicle. In the case of the about 25 million gasoline fueled automobiles in California, this can be done at the about 8000 retail gasoline stations available to them. This is about 3000 cars per gasoline station. This ratio works well because the range of the gasoline vehicle is long (200-500 miles) and the refueling time is short (2-3 minutes). Hence except during inter-city travel, gasoline fueled automobiles need to go to the gas station infrequently and when they do refuel, the time is very short. Unfortunately neither of these factors are true for BEVs and a much smaller ratio of BEVs to charging stations will be required for the reliable use of BEVs.

### **1.1 Present status of the charging network in California in 2015**

The number of chargers in California in 2015 is about 15,000. It is assumed that this figure does not include home chargers, but likely does include workplace chargers. Further it is assumed that most of the chargers are public 220V (Level 2) chargers providing 3kW and 6 kW to charge the batteries and a limited number of fast chargers providing up to 50kW. Tesla has provided fast chargers for their EV owners that provide up to 120 kW. Regardless of the actual number of chargers available, it is generally agreed that the present network is inadequate for the number of EVs on the road. One of the complications of the present situations is that many of the public and workplace chargers provide the electricity free, which means that many EV owners do not utilize their home charging and use the public chargers instead. As a result, they occupy stations needed by those without home charging capability or requiring charging during their travel away from home. Note that the present ratio of charging stations to EVs is about

10:1 and that the number of charging stations already exceeds the number of retail gasoline stations in California.

Most of the charging stations are in urban areas and not along intercity highways, which require fast chargers to be most useful. Only a relatively small fraction of the charger stations have fast charging capability. Most of the available public chargers are slow chargers that charge the batteries with 3-6 kW taking 3-5 hours for a complete charge of vehicle batteries. By fast charging is meant that the battery can be charged in less than 30 minutes to 50% or more of its energy storage capacity and thus the vehicle to 50% of its range potential. The charger power required for fast charging is dependent on the battery size (kWh) and varies between 50kW and 120kW in most cases. Even with a fast charger, a complete charge of the battery would require more than 1 hour because the charging current must be tapered as the battery approaches full charge. A problem at present for intercity travel is that many EVs are not equipped with fast charging capability (>> 6 kW) making them at best regional travel vehicles. The exceptions are some the Nissan Leafs and the Tesla Model S and X.

Most of the fast charger stations available have been installed by Tesla [1] for the sole use of their vehicles. Tesla has installed both fast and slow (destination) chargers. As of September 2015, Tesla has installed in the United States 851 slow chargers and 224 fast chargers with most of the chargers installed from Sept 2014 to September 2015 [1]. Each of the Tesla fast charger stations (4 charger towers per station) can accommodate 8 EVs, but the total power for each tower is limited to 120-135 kW at any time. Most of the Tesla fast chargers in California are positioned (see Figure 1) along the coast between San Diego, Los Angeles, and San Francisco. Most of Tesla slow or destination chargers are located near shopping malls, hotels, restaurants, and ski resorts.

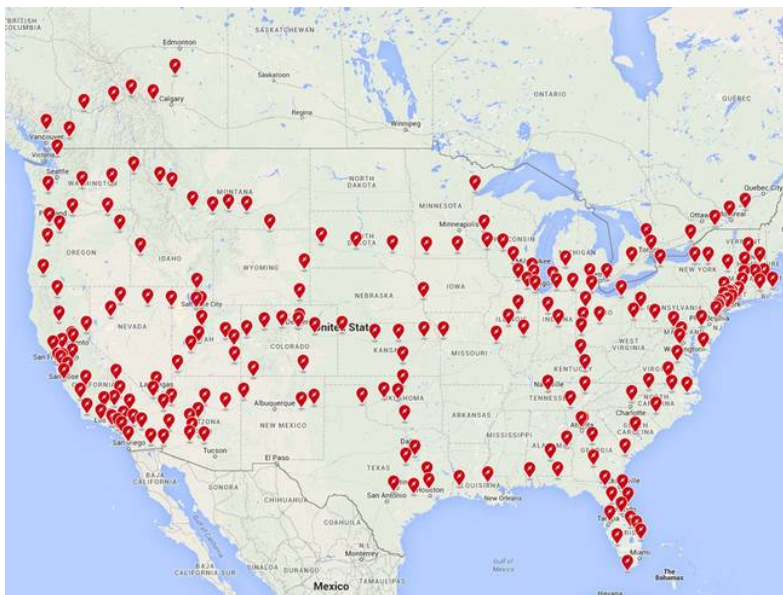

Figure 1. Locations of Tesla chargers in the US

In California, many of the charging stations have been installed with funding from the CEC. As shown in Table 1, the CEC funded chargers are both public and private and are installed in locations accessible to the various groups of EV owners. This includes owners living in multi-family dwellings and those that can use workplace charging. By late 2017, it is expected the CEC will have funded a total of about 4500 non-residential chargers in California and they plan to continue funding chargers in future years as sales of EVs continue to increase.

**Table 1. Summary of the number of CEC funded charger installations [2]**

Charging Connectors	Residential	Multi-unit Dwelling	Commercial	Workplace	Fleet	DC Fast Chargers	Total
Installed	3,937	178	2,039	189	100	43	6,486
Planned	-	167	1,415	236	36	199	2,053
Other				209			209
<b>Total</b>	<b>3,937</b>	<b>345</b>	<b>3,454</b>	<b>634</b>	<b>136</b>	<b>242</b>	<b>8,748</b>

It seems clear from the presentations and discussions at the workshop that the need for a rapid increase in the number of charging stations in California is very great and that funding for these additional chargers should come from both private and public sources. In addition, as longer range EVs (200 miles and greater) become available, it is realized that many more fast chargers will be needed at inter-city locations. At the present time, many of the EVs sold are to early adopters who have home charging and/or workplace charging making them less dependent on public chargers. That will change as EV sales increase and the general public begins to purchase EVs. The need for public charging will also increase as sales of plug-in hybrids (PHEV) continue to increase. In order to operate primarily on electricity, PHEVs will require frequent opportunity charging and thus access to public chargers.

## 1.2 Technologies for battery charging

### 1.2.1 Status of plug-in charging technology

The Electric Vehicle Supply Equipment (EVSE) or Electric Vehicle Charging Station is a device to transfer electricity from the electric grid and dispense the electricity to plug-in electric vehicles. Electric vehicle charging is the process of converting AC electricity from the AC electric grid to DC electricity for charging the batteries of electric vehicles. The power electronics used to convert AC to DC and to control the battery charging is the “charger”. Two basic types of charging stations: AC charging and DC fast charging, have been defined according to where the charger is positioned. The difference is where the AC/DC conversion and the charging control takes place. This is illustrated in Figure 2.

All charging systems take AC power from the grid and convert it to DC power at a suitable voltage for charging the battery. AC Level 1 and AC Level 2 charging are low power charging and are implemented by the vehicle onboard charger. AC Level 1 and Level 2 charging stations

merely deliver the AC power to the vehicle. DC fast Level 1 and Level 2 charging requires high power, expensive power electronics. The AC/DC conversion and the power conditioning and control are exercised in the charger off the vehicle within the charging station. Table 2 summarizes the charging power, supply power requirement, and connectors/plugs for the various chargers. The battery management system (BMS) provides the charger the required constant current / constant voltage charging profiles.

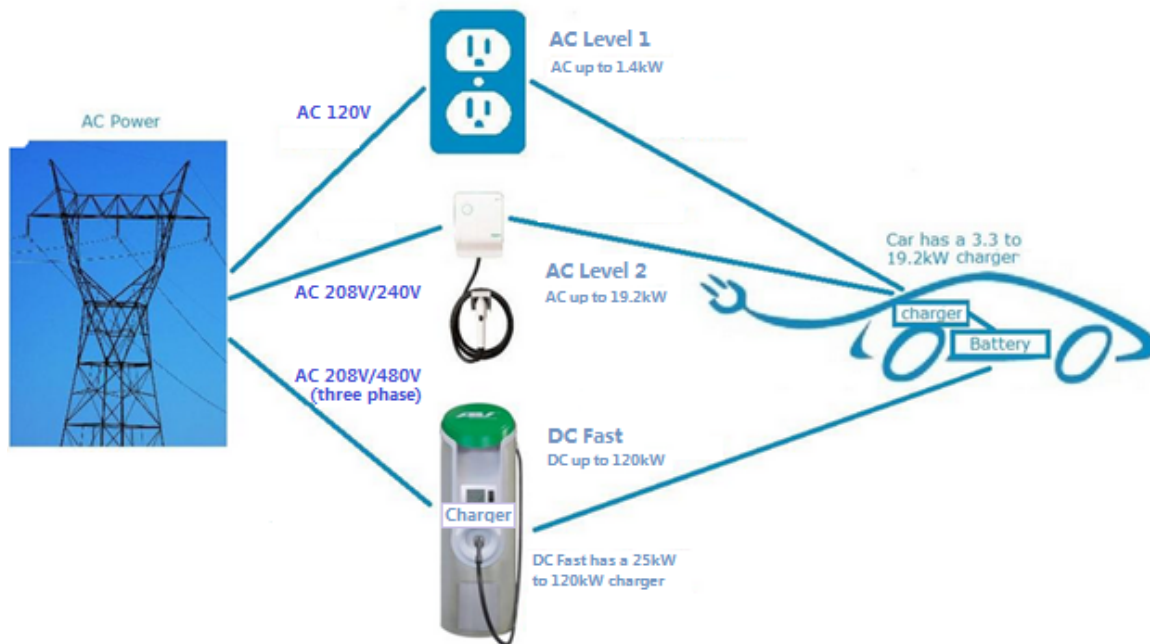

**Figure 2. AC and DC Charging Paths (modified diagram from [32])**









AC Level 1 charging uses a standard 120 V plug. Any garage or property with electricity can be a potential charge point for the PEVs with a portable charging unit. The portable charging unit comes standard with the vehicle and can plug into conventional 120 V outlets. Since the adoption of the standard connector – SAE J1772, every new PEV can be charged at all AC Level 2 charging stations available in the United States.

For DC fast charging, there are three charging connector standards in various stages of adoption - CHAdeMO, Tesla Supercharger, and SAE J1772 Combo or CCS (combined coupler standard). CHAdeMO, the Japanese Electric Vehicle Standard, is the most established and the only commercially available DC fast charger connector standard used today. It has been implemented by several large automakers and several dozen of chargers manufacturers. The Tesla Supercharger connector system is used only on Tesla vehicles, but Tesla is working on an adaptor to make their charging setup compatible with the CHAdeMO and SAE systems. The latest fast charge connection system is the SAE J1772 Combo, adopted by Chevy Spark EV and Bolt and the BMW i3. These three DC fast charging system interfaces are not physically compatible. Discussions are ongoing in an attempt to establish a common standard for the fast

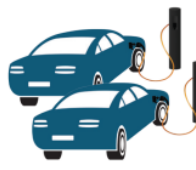

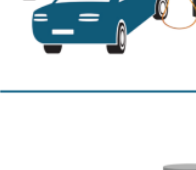
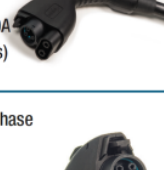
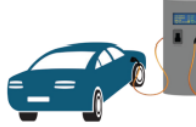
charging connection system. Agreement is needed before large numbers of PEVs with fast charging capability reach the market.

**Table 2. Power boundary between different charging types and levels [33]**

Charging Level	Setting	Supply Power	Representative Example	Where Charging Occurs
 <b>AC Level 1</b>	Residential/ Parking Lot 5 mi/hour @ 1.7 kW	120vac/20A (16A continuous)		<b>RESIDENTIAL</b>  1/3 of charging
 <b>AC Level 2 (minimum)</b>	Residential/ Commercial 10 mi/hour @ 3.4 kW	208/240vac/20A (16A continuous)		<b>2/3 of charging</b>
 <b>AC Level 2 (maximum)</b>	Commercial (up to) 60 mi/hour @ 19.2 kW	208/240vac/100A (80A continuous)		
 <b>DC Level 1</b>	Commercial up to 500v @ 80Adc (up to) 120 mi/hour @ 40 kW	208vac/480vac 3-phase (input current proportional to output power; ~20A-200A AC)		<b>COMMERCIAL</b>  1/3 of charging
 <b>DC Level 2</b>	Commercial up to 500v @ 200Adc (up to) 300 mi/hour @ 100 kW	208vac/480vac 3-phase (input current proportional to output power; ~20A-400A AC)		

The PEV market is growing relatively slowly, but the charging station market has shown rapid growth. The costs of the charging station vary widely depending on power levels, number of charge points, and if it is networked. Charging stations can support both Level 1 and Level 2 charging. Fast chargers are very different in design, cost, and complexity. Table 3 lists major EVSE products available on the market and their range of power level and price.

AC Level 1 EVSEs operate at 15 A/1.8 kW. Most PEVs come with an AC Level 1 EVSE cordset so that no additional charging equipment is required. Based on the vehicle onboard charger and circuit capacity, AC Level 2 charging stations operate at 15 A – 32 A, delivering 3.3 – 7.2 kW of electric power to the onboard charger with the cost in the range \$450 - \$5000. The majority of current DC fast charge stations use either a CHAdeMo or SAE Combo connection system to provide 50 kW charging at 125 A at a price between \$19,000 – \$40,000. Tesla charge stations provide 120 kW per station and have been designed by Tesla for use with their EVs.

**Table 3. Major EVSE products – Make, Power Level, and Price**

Level	Make / Model	Max Amps & Power	Price
Level 1	ChargePoint CT2100 Series ClipperCreek PCS-15, ACS Eaton 120VAC Universal Receptacle EV-Charger America EV2000 EVExtend Commercial Level 1 Leviton Evr-Green 120 Shorepower WU-120, SC2-120 Telefonix L1 PowerPost	10 A – 20 A  1.2 kW - 2.4 kW  Most operate at 15 A – 16 A	\$400 - \$2,900
Level 2	Aerovironment EVSE-RS Bosch Power Max ChargePoint CT2000, CT500, CT2100, CT4000 Series ClipperCreek LCS Series BDT GNS, BBR Series Delta AC and Pedestal Mount Eaton Pow-R-Station Ecotality Blink EV-Charge America EV2100, EV2200 Series Evatran level 2 General Electric WattStation, DuraStation GoSmart ChargeSpot RF Green Garage Associates Juice Bar GRIDbot UP-100J Legrand Level 2 Leviton Evr-Green 160, 320, Level 2 Fleet, CT Level 2 Milbank EV Pedestal OpConnect EVCS ParkPod Plug-in Electric Power (PEP) Level 2 Schneider Electric EVlink Outdoor, Square D Indoor SemaConnect ChargePro 620 Siemens Smart Grid EVSE, VersiCharge	16 A - 75 A  3.6 kW - 20 kW  Most provide 30 A - 32 A, 7.2 kW - 7.6 kW	\$450 - \$5,000

	SPX Power Xpress Telefonix L2 PowerPost EVSE Volta Charging EVSE		
DC Fast	ABB Terra 51 Fast Charger Aerovironment Fleet Fast Line, DC Fast Charge Aker Wade Level III Fast Charger Andromeda Power ORCA-Mobile Delta EV DC Quick Charger Eaton Pow-R-Station DC Quick Charger Ecotality Blink DC Fast Charger Efacec QC50 Epyon Power Terra 50.X System, 50.1 Charge Station EVTEC MobileFastCharger, PublicFastCharger Fuji FRCH50B-2-01 Nichicon Quick Charger Nissan NSQC-44 Series Schneider Electric Fast Charger Tesla Motors Supercharger	60A-550A 20kW-60kW  Most are 125A 50kW	\$19,000 - \$40,000

Charging time is not only governed by the power level of the charging equipment, but also is limited by the size of the onboard charger, the capacity (kWh) of battery pack, and the taper characteristics of battery chemistry. The early model-year plug-in electric vehicles such as Nissan Leaf and Chevy Volt had a 3.3 kW onboard AC charger, but later Leafs were upgraded to 6.6 kW onboard chargers. Honda Fit EV and the Ford Focus EVs also have at 6.6 kW chargers. The Tesla Model S comes standard with a 10 kW onboard AC charger or an optional dual AC charger of 20 kW.

In the present EV market, most of the vehicles have an EPA-rated range of 75-80 miles with a battery capacity of 20-24 kWh. The Tesla Model S has either a 60 kWh or 85 kWh battery pack, which provide estimated ranges of 170 and 220 miles, respectively. Charging times on Level 2 chargers for the 24 kWh batteries are about 4 hours and for the large Tesla batteries from 6-9 hours. The battery management system (BMS) provides the required current command to the charger. The charging starts with a constant current until the voltage reaches a set value. Unless a full charge is desired, charging is stopped. If a complete charge is desired, the charging is continued with current taper at constant voltage control until the charge current reaches a specified small value. For fast charging, the current can be decreased even before the final voltage is reached to protect the battery from overheating. It is common to provide only 50-60% of full charge in fast charging.

## 1.2.2 Status of wireless charging technology

“Plugging in” is not considered convenient by many owners of PEVs. Hence they do not charge the batteries in their vehicles as often as is required to maximize the use of electricity. However, the introduction of wireless charging could make charging more convenient for PEV owners [3]. For the home charging market, the main benefit of wireless charging is convenience. In public or workplace charging applications, wireless offers the additional benefits of reducing the clutter of cables and the risks of vandalism. Recently, several wireless charging manufacturers have developed wireless charging products, and several major automakers have indicated that they will offer wireless charging options for future PEVs. The latest wireless charging technologies offer increased efficiency and the requirement for less precise position alignment of the charging pad and the vehicle receiver than earlier wireless technologies.

Magnetic resonance technology has been developed by several wireless EV charging manufacturers. It is different from the traditional inductive power transfer technology and is enhanced by using two or more pairs of RLC resonators to extend operating range and increase power transfer efficiency. Different prototypes with serial and parallel compensation topologies (shown in Figure 3) have been developed for various charging applications.

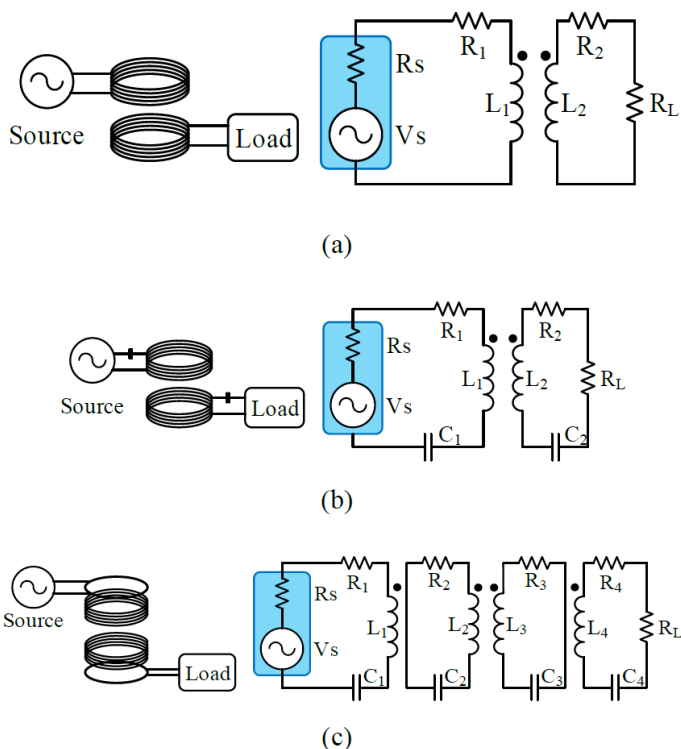

**Figure 3. Wireless power transfer technologies: (a) traditional inductive power transfer; (b) coupled magnetic resonance; and (c) strongly coupled magnetic resonance [4]**

The only wireless charger on the market today is Plugless by Evatran. Since the receivers have to be custom-made for different vehicles, Evatran developed Plugless 3.3 kW models for the Nissan Leaf, Chevrolet Volt, and Cadillac ELR, and a 7.2 kW model for the Model S (Figure 4). Evatran claims that Plugless is ~12% less efficient than a plug Level 2, 30 amp, 240V charging systems and ~7% less efficient than plug Level 1 charging systems [5]. WiTricity is working with several major automakers and OEM part suppliers and has demonstrated their wireless charging technology (Figure 5) in the Toyota PHEV Prius, Honda Fit EV, Mitsubishi i-MiEV, and Audi A3 e-tron. WiTricity has licensees in the automotive, consumer electronics, medical, industrial, and military markets. Qualcomm acquired the former HaloIPT company and has demonstrated its Halo wireless charging system in various vehicles, including the Drayson B12/69 electric race car. Currently, Qualcomm works with Ricardo to commercialize Qualcomm Halo wireless EV charging technology (Figure 6) in Europe. The Halo wireless charger can transfer up to 3.5 kW at greater than 90% efficiency.

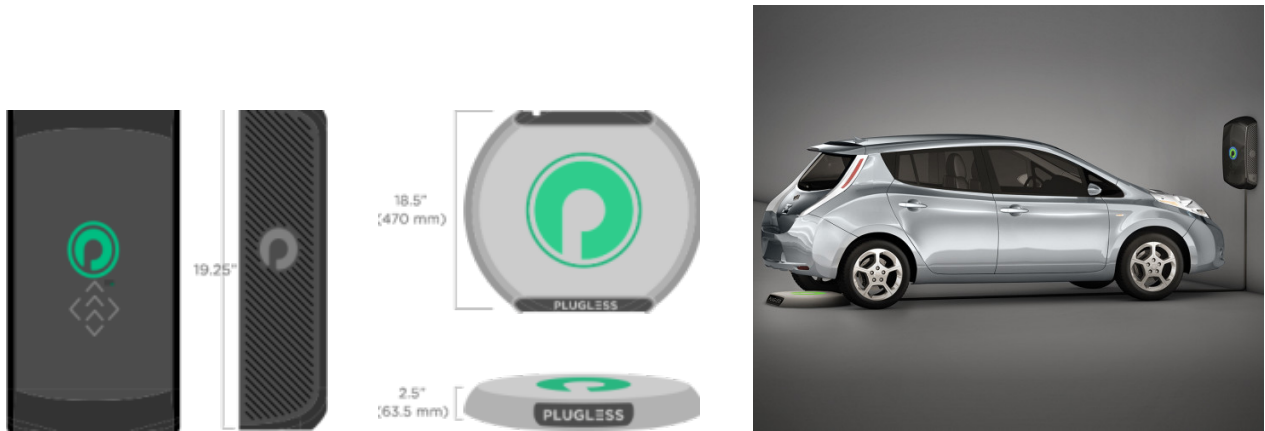

Figure 4. Plugless Charging from Evatran



Figure 5. WiTricity wireless power transfer systems



**Figure 6. Qualcomm Halo Wireless Charging**

Navigant Research forecasts that wireless charging sales for light-duty vehicles will begin to grow rapidly in the next few years (see Figure 7) reaching annual sales of about 300,000 units in 2022 [6, 7].

**Chart 1 Wireless EVSE Unit Sales by Region, World Markets: 2013-2022**

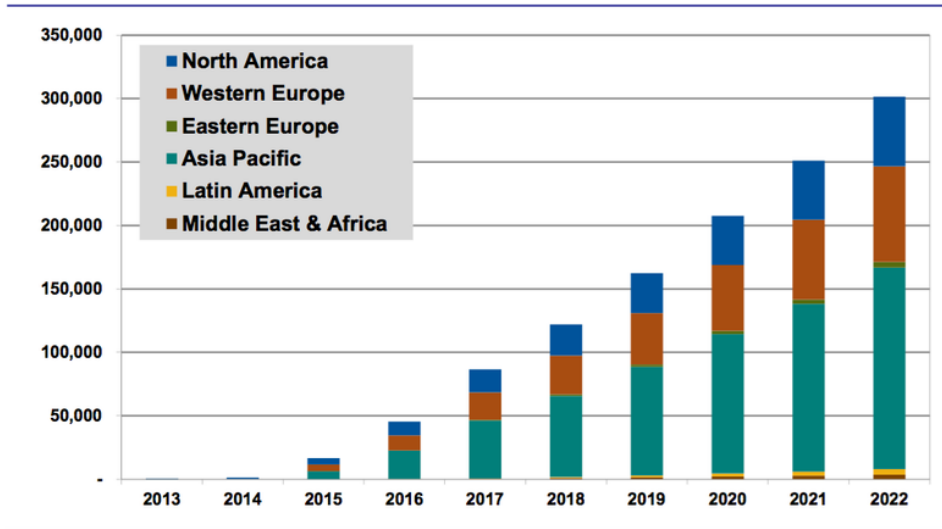

(Source: Navigant Research)

**Figure 7. Wireless EV charging sales projection [Navigant Research]**

### Wireless EV charging standards

The SAE has published the first wireless charging standard, “SAE TIR J2954 Wireless Power Transfer for Light-Duty Plug-In/ Electric Vehicles and Alignment Methodology” [8]. The new

standard creates a wireless charging protocol for low speed charging and can accommodate higher speed charging options. This will allow PEVs from different automakers to share wireless charging stations. Major light-duty PEV automakers including GM, Ford, Honda, Toyota, Nissan, Daimler, BMW, etc., plug-in transit bus manufacturers such as Volvo, BYD, Proterra, and Gillig, and several Tier 1 suppliers such as Delphi, Evatran, Qualcomm Halo, Wave, WiTricity, LG, Panasonic, TDK, etc. have adopted the new SAE guidelines [7, 9].

SAE TIR J2954 establishes a common frequency band using 85 kHz (81.39 - 90 kHz) for all light duty vehicle charging systems. The four Wireless Power Transfer levels (WPT1-4) are defined for PEV charging and with even higher power levels reserved for the future.

- 3.7kW (WPT 1) specified in TIR J2954
- 7.7kW (WPT 2) specified in TIR J2954
- 11kW (WPT 3) to be specified in revision of J2954
- 22kW (WPT 4) to be specified in revision of J2954

SAE TIR J2954 WPT compatible wireless charging systems have been developed and are currently under bench and in-vehicle testing with a 2018 target for demonstration of compliance with the standard.

### 1.2.3 Battery/vehicle design to facilitate fast charging

Thermal management of the battery pack is important for reasons of Safety and preservation of cycle life. Heat is generated in the battery during vehicle acceleration, braking, and high climbing. Heat is also generated during battery charging. The heat generated during Level 2 and Level 3 charging up to about 50 kW can be handled by the normal battery cooling system needed for normal vehicle operation. The pulse power during accelerations and braking can be very high, but the time is short so the total heat generated is not large. The heat (energy) generated during high climbing can be large if the electric motor has a high continuous power rating (kW). For a very fast charger with power greater than 100 kW, the heat generated can be large because the power loss ( $I_{\text{chg}}^2 R_{\text{bat}}$ ) is reasonably high and time (10-30 minutes) of the charge is not short. Hence it seems clear that the fast charging cooling requirement can be important in designing the thermal management system of the battery pack. At the present time (2016), only a fraction of the PEVs have fast charge capability. Only the Tesla EVs have very fast charge (>100 kW) capability. However, in the future it is likely that many PEV models will have fast charging capability so that they can be used for inter-city travel.

Calculation of the power loss ( $P_{\text{loss}} = I_{\text{chg}}^2 R_{\text{bat}}$ ) is straightforward if the resistance of the battery is known. The resistance of the battery is given by  $R_{\text{bat}} = n_s R_{\text{cell}} / n_p$ , where  $R_{\text{cell}}$ . The cell resistance depends on the Ah size of the cell. For most cell technologies,  $R_{\text{cell}} \times \text{Ah}_{\text{cell}} = \text{constant} = C_{\text{bat}}$ , which is in the range of .03-.05 for high power lithium batteries. In general, the current  $I_{\text{chg}}$  for a specific charge time or  $n_{\text{chg}}C$  is related to the effective Ah rating ( $n_p \text{Ah}_{\text{cell}}$ ) of each unit connected in series. The charge time is 60 minutes/ $n_{\text{chg}}$  and the charge current  $I_{\text{chg}} = n_{\text{chg}} n_p \text{Ah}_{\text{cell}}$ . For example, if  $n_{\text{chg}} = 3$ ,  $n_p = 4$ ,  $\text{Ah}_{\text{cell}} = 30$ , the charge current for a complete 20 minute charge would be 360 A. If it was desired to only return 60% of a full charge to the battery, the charge

current would be 220 A. In the case of a full charge, the current would have to be tapered as the full charge is approached.

These simple relationships can be used to calculate the power loss for batteries of various sizes (kWh). Consider the case of a 360 V (nominal) pack using 20 Ah cells having a resistance of 3 mOhm and a 20 minute charge to 60% full charge. Typical results for fast charging conditions are shown in Table 4.

**Table 4. Fast charging conditions for a 360V battery**

kWh nom/act.	$n_s$	$n_p$	$I_{chg}$ A	$R_{bat}$ Ohm	$P_{loss}$ kW	$P_{bat,chg}$
50/50.4	100	7	252	.043	2.73	90
60/57.6	100	8	288	.038	3.15	103
70/72	100	10	360	.030	3.89	130
80/79	100	11	396	.027	4.2	142

20 Ah cells, 3 mOhm/cell, 20 minute charge to 60% full charge

It seems likely the battery thermal management system would be designed to handle the heat generated from the continuous operation of the motor as in hill climbing. If the continuous rating of the motor used in the PEV is significantly greater than the battery charging power required for fast charging, then the battery thermal management should be able to handle the heat generated during fast charging. Otherwise, the heat load due to fast charging will be the design requirement for the thermal management of the battery pack.

The desired operating temperature for optimum battery performance and life is between 15 deg. C and 35 deg. C, which varies with battery chemistry. Battery power and capacity are significantly limited at cold temperatures due to sluggish electrochemistry. At higher temperature, battery power is limited by the increasing temperature, which could lead to battery degradation. In addition, the temperature differences in the battery pack should be controlled to less than 3 – 4 deg.C for most battery chemistries [11].

Battery thermal management is necessary during both high and low temperature operation. Cooling is typically required for operation in hot environments and during moderate to high power operation and fast charging. Heating is needed in cold environments during charging and discharging to avoid battery damage and low performance. Different cooling and heating systems have been developed for electric vehicle batteries. Several HEV batteries are thermally managed by air heating and cooling using outside ambient air or cabin air (Figure 8(a)), which is considered to be a traditional passive thermal management system. Passive thermal management is simple and lightweight, but doesn't work well under extreme conditions. Batteries in PHEVs and EVs require more efficient cooling. Liquid cooling that has a higher heat



transfer coefficient is typically used and active battery thermal management is often needed in PHEVs and EVs. Active thermal management usually employs several fluid loops, as shown in Figure 8(b). The main cooling/heating loop cools the drivetrain and heats the cabin, the refrigerant loop cools the cabin, and the third loop manages the battery system. The design of this loop is critical in the case of providing fast charging capability for the EV.

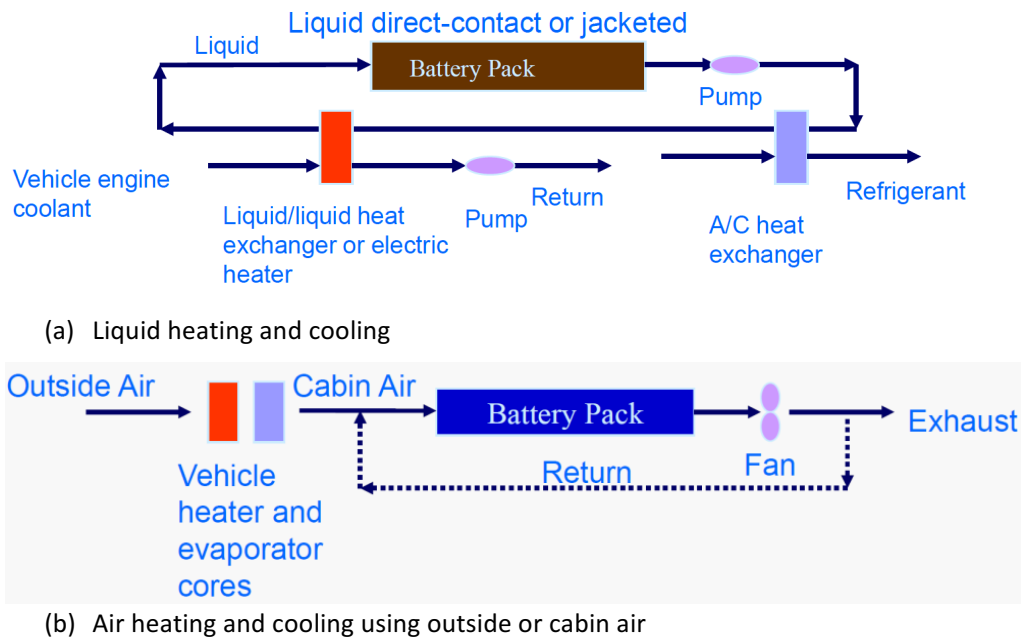
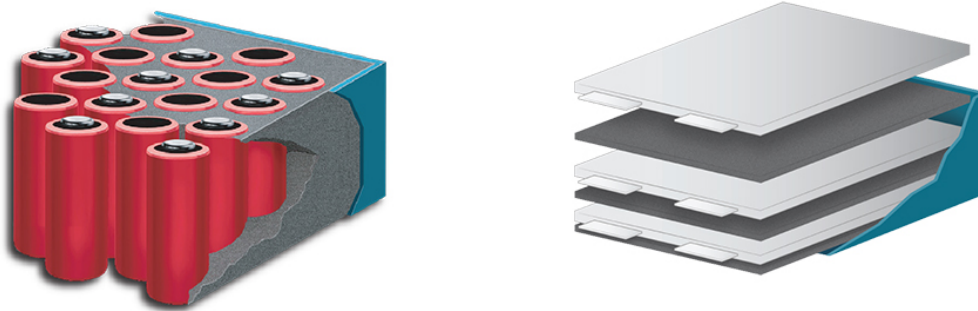

**Figure 8. Battery thermal management [11]**

The current liquid cooling systems that use a liquid heat exchanger (radiator) and a condenser/evaporator AC heat exchanger function well during charging and vehicle operation. Most of current PEVs use this type of cooling system. However, the move to higher-power charging such as the Tesla Supercharger 135 kW, CHAdeMo 150 kW, and potential charging power up to 240 kW require more cooling. As indicated in Table 4, the fast charging cooling requirement can be in excess of 5 kW for large batteries, short charging times, and more than 50% charge fraction. Conventional liquid cooling systems may be unable to handle the excess heat, especially uneven temperature distributions and hot spots across cells and modules. Using phase change materials (PCM) (also called phase change composites (PCC)) between the cells of battery modules can help maintain the temperature inside the battery within operational limits and maintain temperature uniformity across the cell, as shown in Figure 9. As discussed in the following paragraph, PCM thermal systems are under development, but these advanced systems are not yet in production EVs.

The PCMs is placed around the cylindrical cells and between the prismatic cells in the module. The melting point of the selected PCMs should match the optimum operating temperature of the battery. The PCM absorbs the heat generated by the battery, and the temperature increases until the PCM reaches its melting point. Further heat will lead to phase change

without further temperature increase. The heat from the liquid PCM will be rejected through the conventional cooling system. Reference [12] provides a trade-off analysis of various battery thermal management systems and summarizes the properties of some PCMs. Comparative analysis of different thermal management systems are given in Table 5 [12]. Combining PCMs with active thermal management provides an effective approach for managing the heating/cooling of the automotive traction battery in PHEVs and EVs.



**Figure 9. PCMs around cylindrical cells and between prismatic cells [13]**

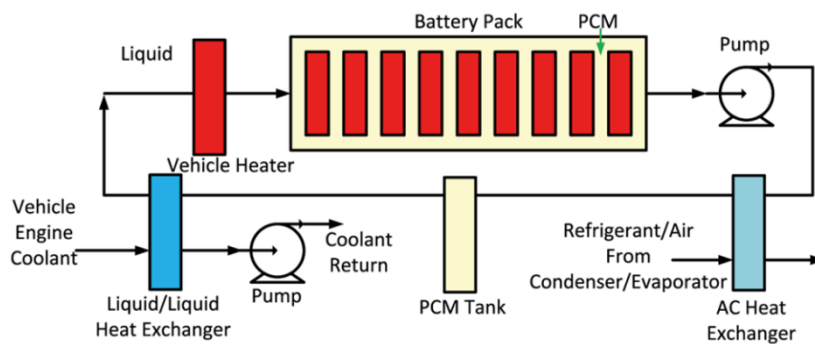

**Figure 10. Thermal management systems using a liquid coolant and a PCM in between cells and in the external tank [12]**

**Table 5. Trade-off analysis of various battery thermal management systems [12]**

	Air forced	Liquid	Heat pipe	PCM	Thermoelectric	Cold plate
Life	≥20 years	3–5 years	≥20 years	≥20 years	1–3 years	≥20 years
Ease of use	Easy	Difficult	Moderate	Easy	Moderate	Moderate
Integration	Easy	Difficult	Moderate	Easy	Moderate	Moderate
Maintenance	Easy	Difficult	Moderate	Easy	Difficult	Moderate
Temperature distribution	Uneven	Even	Moderate	Even	Moderate	Moderate
Efficiency	Low	High	High	High	Low	Medium
Temperature drop in cell	Small	Large	Large	Large	Medium	Medium
Annual cost	Low	High	Moderate	Low	High	Moderate
First cost	Low	High	High	Moderate	High	High

### **1.2.4 Battery charging using previously stored electricity**

If low cost electricity from the grid or renewable solar PV electricity is available at times at which vehicle battery charging is not needed, it can be advantageous to store the energy for later use. The battery needed would be of comparable size to that in the vehicle in the case of home charging or much larger if a number of vehicles are to be charged at the site. The economics of this approach is problematical because of the high cost of the energy storage battery unless the effective cost of the stored electricity is very low. This could be the case for renewable solar electricity or for high power charging stations with very high demand charges. There is some possibility that the cost of the storage battery could be significantly reduced if that battery was made up of second-use modules taken from electric vehicles. This could be especially attractive for home charging with PV panels where the charging rates are relatively low (<10 kW). The technology for this approach is well developed and readily available.

### **1.3 Role of the utilities in providing charging infrastructure**

California had about 20,000 public charge points for PEVs in 2015 and projections are that the State will need to add about 30,000 charge points per year from 2016-2025 to service 1.5 million PEVs. It became clear in 2013-2015 that depending on State and private investment to build the PEV infrastructure without participation of the electric utilities would not result in the addition of the needed charging stations. The utilities have been proponents of PEVs in California and are anxious to provide charging stations by the 10's of thousand to recharge the batteries in the vehicles. However, in 2011 [14], a California Public Utility Commission (CPUC) ruling banned utilities from becoming investors in public EV charging, saying they had an unfair competitive advantage over independent companies desiring to enter the market and in 2014 [15], the CPUC rejected proposals from the major utilities to build a large number (25000-30000) of charging stations. In 2016, the major utilities-PG&E, Southern California Edison (SCE), and San Diego Gas & Electric (SDG&E) in California submitted new proposals [16, 17]. These proposals were much smaller in scope and the utilities proposed to fund and own only the substructures needed to deliver the electricity to the charging station. The charge dispensing hardware and operation of the station would be funded and controlled by a third party. This would permit strong competition between various companies desiring to provide the PEV infrastructure. In 2016, the CPUC began approving the new proposals from the utilities [18, 19]. These proposals would result in rate-payer –funded investments in EV charging and have provisions to assure fair competition as the market develops.

The first proposed utility program approved by the CPUC was that of Southern California Edison (SCE) [18]. It was rather simple in concept. It permitted the utility to install and maintain the electrical infrastructure for charging stations and cover the costs from rate-payer revenues. The charging stations would be installed at locations where people park their cars for extended periods (workplaces, campuses, recreation areas, apartment complexes). Pre-qualified charging station hardware would be installed, owned, and operated by independent companies in a competitive market. SCE would offer rebates between 25 and 100% of the cost of completing the charging station. The first phase of the program would support installation of

up to 1500 charging stations within SCE's territory. If the initial pilot project is successful, SCE would seek to expand the program to install a total of 30,000 charging stations.

The second utility proposal approved by the CPUC was for SDG&E [19] to have installed 3500 charge points at 350 locations where PEVs would be parked for extended periods (businesses and multi-family communities). SDG&E would own the charging stations, but they would contract with third parties to build, install, operate and maintain them. A key feature of the SDG&E program is that the chargers will be integrated into the grid permitting the utility to study the benefits to its customers of dynamic, off-peak pricing of the electricity to charge the batteries. The pilot program will also assess the value of PEV charging on managing the variable output from renewable solar sources. These benefits to the customers and the utility are likely the reasons the CPUC permitted the utility to own the charging stations in the relatively small pilot program. If the program is successful, SDG&E desires to increase the number of charge points to 30,000 in future years.

PG&E has submitted several proposals [20] to the CPUC over the last couple of years to install PEV charging stations, but has not had a proposal accepted as of June 2016. PG&E initially proposed to install 25,000 charging stations in their territory. They would own the charging stations and make all decisions concerning their construction and operation. The latest proposal submitted in October 2015 is for 7500 charging stations over 3 years with most of the chargers being in placed in multi-family dwellings and workplaces. The project also included 100 fast chargers. It would be funded primarily from revenue from rate-payers. PG&E would retain some control over the choice of hardware installed and the electricity rates charged. Both of these issues remain contentious with the third parties involved in the project.

All the PEV charging station projects are of pilot size and the utilities and the CPUC are seeking a better understanding of the best approach to pursue the large projects (25000-30000) desired by the utilities. It is generally agreed that these large projects will be needed to provide charging services for 1-1.5 million PEVs in 2020-2025. Each of the large projects would cost in excess of \$500 million with that cost being met from utility revenue from rate-payers. Since this would result in slightly higher customer electricity rates, the CPUC wants to be sure the approach for financing the charging stations by the utilities is fair to the public and the companies building and operating the charging stations.

## **1.4 Charging infrastructure for 1.5 million PEVs by 2025**

Early in 2016, there were about 200,000 plug-in electric vehicles (PEVs) on the road in California [21]. It is estimated that there are about 20,000 public charger stations to serve these PEVs or about 10 PEVs per charging station. If this ratio of PEV to charging station were adequate, California would need 100,000 charging stations in 2020 and 150,000 stations in 2025. Conventional thinking is that the present ratio is not adequate and many more charging stations will be needed. The California 2015 ZEV Action Plan [22] suggests the state will need upwards of 900,000 charging points in 2020 to serve the 1 million PEVs on the road. That would be a ratio of about 1:1 charging points to PEVs. These charging points should include

home and apartment, workplace, city public, and highway/intercity chargers. Some of the city public and most of the highway chargers would be fast chargers in less than 30 minutes.

At the present time, there are about 25 million gasoline fueled cars on the road in California and about 8000 gasoline fueling stations to serve them resulting in 3000 cars per fueling station. The refueling time for conventional cars is short being only 2-3 minutes and most stations can serve 5-10 vehicles at one time. Refueling stops for gasoline fueled cars are often less than 5 minutes. Except on intercity trips, it is reasonable to assume refueling of conventional cars about every two weeks.

The number of gasoline stations available seems to refuel the 25 million conventional cars very well in California. It is of interest to estimate the number of PEV charging stations needed to serve the 1 million PEVs in 2020. In order to do this, it is necessary to make a number of assumptions. First, assume that 2/3 of the PEVs will be charged at public charge points and that each charge event is 5 hr. and each vehicle is charged 4 times per week. Each charger would be available 7 days per week and 24 hours per day. It will be used some fraction of the day- say 50%. Equating the number of hours of charging needed with the number of hours per week available, the following equation gives an estimate of the number of chargers (Level 2, 6-10 kW) needed to charge vehicles in the urban areas of California.

$$\frac{2}{3} \times N_{PEVs} \times 5 \times 4 = N_{chargers} \times 7 \times 24 \times .5$$

Evaluating the equation,  $N_{chargers}/N_{PEVs} = .158$  or 6.3 PEVs per charger. This means about 160,000 charge points for 1 million PEVs. This is about 10 times the number of chargers in California in 2016. The number of fast charge points needed to facilitated intercity travel in California can be estimated from the mileage of interstate designated highways. This mileage is 43000 miles. If the chargers are spaced 50 miles apart on average, the number of fast charger stations (charge in less than 30 minutes for a 200 mile EV) would be 860. If each fast charge station included multiple charge points (approximately 10), this would result in about 10,000 fast charge points. It appears that the number of fast charge points is much less than the slow, Level 2 charge points even if some fast chargers are included in city areas. Hence California will need about 200,000 charge points in 2020 and about 300,000 charge points in 2025 to serve 1.5 million PEVs. This number is much less than suggested in [22], but the basis of the 900,000 number was not presented in[22].

If California is to reach 1.5 million PEVs in 2025, sales of PEVs will have to average about 150,000 per year between 2017-2025 and about 30,000 new charge points will be needed each year. About 1500 of these chargers should be fast charge points. It has been assumed that all the sales are EVs. However, it is expected that a significant fraction of the sales will be PHEVs with an all-electric range of 20-50 miles. The PHEVs will require charging more frequently than the BEVs, but there charge time will be much shorter. Hence total time needed for charging for the PHEVs may not be much different than for the BEVs on a daily basis. It is not likely the PHEVs will have fast charge capability so they would have to use Level 2 chargers even at the highway charging stations.

## **1.5 Role of Federal, State, and regional government policies and incentives**

Governments at all levels currently recognize the need for the installation of battery charging facilities at residences (single and multiple family), workplaces, and public parking areas both in the city and along highways. This is especially true in California. The role of governments is to offer grants and financial incentives to individuals and businesses to install battery charging and policies to permit the electric utilities to be a dominant player in providing battery charging facilities.

Congress has renewed the federal tax credit [23] for individuals and business for the purchase and installation of electric vehicle charging stations as part of the Alternative Fuel Infrastructure Tax Credit law. The credit applies to installations between January 1, 2015 and December 31, 2016. For home chargers, the tax credit is 30% of the cost of the charger up to \$1000 and for businesses, it is 30% up to \$30,000. California [24] has a number of programs where individuals and businesses can get loans for installing battery chargers under favorable terms for repayment.

There are competitive grants available from the CEC for the installation of public charging stations. In most cases, these grants (see Table 1) are for the installation of 10-100 stations per grant, but the CEC program was important in initiating the installation of charging infrastructure throughout California. The CEC grants were for both Level 2 and fast charging stations. A number of Air Quality Management Districts and Public Utility Districts in California offer rebates for the installation of charging stations primarily to businesses.

The grants, tax credits, and rebates cited in the previous paragraphs have resulted in the installation of about 20,000 charging stations in California by 2015. However, in order to meet the States' goal of 1 million PEVs by 2020 and 1.5 million by 2025, the analysis given in the previous section indicates California will need 200,000-300,000 charge points by 2025. To date, the only entities that seem willing and able to provide this large increase in charging facilities are the electric utilities, such as SCE, SDG&E, and PG&E. All three of these utilities have proposed to the CPUC to install up to 30,000 charging stations over the next three years in areas in which large number of vehicles are parked. As discussed in Sec.2.3, the CPUC did not approve these large projects which would be funded using revenue from all rate-payers and rather approved small projects intended to install 3000-5000 charging stations as pilot projects. Hopefully, the lessons learned from these relatively small projects will permit the utilities or other private business to install the large number of charging stations needed by 2025.

## **1.6 Present and projected costs of charging stations for light-duty PEVs**

There have been several detailed studies [25, 26] of the cost of installing and operating Level 1 and Level 2 public charging facilities and limited attention to the cost of Level 3 stations [27]. For Level 1 and 2 chargers, the main costs of installing the charging facility are the cost of the Electric Vehicle Supply Equipment (EVSE), which is the hardware link between the available electricity supply and the electric vehicle, and the cost of installation. The cost of installation, which is dominated by the distance and area complexity between the nearest source of suitable

electrical power and the charger location, can vary by a large amount (\$). The operating costs of the chargers depend on the cost of the electricity, insurance, and maintenance requirements and the cost of networking and management. Profitability of the charging stations depends primarily on its utilization and markup of the electricity tolerated by users of the station. In recent years, the installation costs of the public charging facilities have been highly subsidized by Federal and State grants and incentives. In addition, in some cases, the electricity has been provided free to the EVs. Hence economics has not played much of a role in providing the charging infrastructure presently available. Clearly this cannot continue to be the situation in the future as the charging infrastructure for PEVs is greatly expanded.

The US DOE has studied [26, 28] in detail the cost of installing Level 1 and 2 chargers and fast chargers. The results of the studies are summarized in Table 6.

**Table 6. Summary of costs for the commercial installation of various types of chargers**

Type of charger	Charger power kW	Cost of EVSE (single point) (\$)	Installation cost (\$)	Total cost \$
Level 1	1.4	200-400	0-500	200-700
Level 2	6.6	500-800	600-3000	1100-3800
DCFC	50	20000-40000	4000-15000	24000-55000

At the present time, the cost to install chargers varies over a wide range primarily because the chargers are being installed at less than optimum locations by contractors that are not very experienced in installing them. Also most of the charger projects are highly subsidized by government grants and incentives. It is expected that the charger projects will decrease in cost as they become more competitive and the contractors are more experienced. The costs should decrease closer to the lower range of the costs shown in Table 6. Another factor that should reduce the cost per charge point is that in the future more chargers will be built with multiple charge points.

It is of interest to make a simple analysis of the profitability of charge stations and estimate how long it might take the owner of the station to payback the cost of the station. Consider the case of a commercial Level 2 charger. The owner of the charger needs to recover the cost of the charger and other operating expenses from net revenue from its operation. Operating expenses include the cost of electricity, labor, insurance, networking, and maintenance. The net revenue results from the rental per hour of the charger and the markup on the electricity. A key factor in determining profitability is the utilization of the charging station- in other words, the average hours per day ( $n_{hr}/day$ ) that an EV is using/connected to the charger. The owner desires to recover the cost of charger in  $N_{recov}$  years. Equating the capital costs to the net revenue over  $N_{recov}$ , one can write the following relationship:

$$C_{chg} = (-expenses/hr + Chg\ rental/hr + P_{chg} \times (\$/kWh)_{electmarkup}) 365 \times N_{recov} \times n_{hr}/day$$

As an example of a Level 2 charger, assume

$C_{\text{chg}} = \$3000$ , expenses/hr = .30, Chg rental/hr= 1,  $P_{\text{Chg}} = 6.6$ ,  $(\$/\text{kWh})_{\text{electmarkup}} = .03$ ,  $N_{\text{recov}} = 3$

For this case, the  $n_{\text{hr}}/\text{day}$  is 3.05 or one car per day. Hence Level 2 chargers could be profitable in urban areas in the relatively near future.

Next consider an example of a fast charger. In this case, assume

$C_{\text{chg}} = \$35,000$ , expenses/hr = .60, Chg rental/hr= 2,  $P_{\text{Chg}} = 45$ ,  $(\$/\text{kWh})_{\text{electmarkup}} = .05$ ,  $N_{\text{recov}} = 3$

The calculated utilization required for the fast charger is 7.1 hr/day. For the fast charger, this represents 15-20 cars depending on the charging time of the cars. Hence there appears to be a large difference in the utilization required for profitability of Level 2 and fast charger stations. Hence, the business case for fast chargers will be difficult until there are large numbers of EVs traveling on the highways from city-to-city.

## **1.7 Ways of reducing cost and inconvenience of charging to purchasers of PEVs**

### **1.7.1 Provision for home charging**

Home charging is the most convenient and can provide the lowest cost electricity for PEV owners living in single family dwellings. However, only a relatively small fraction of the public lives in single family houses especially in large urban areas. The cost of installing a charging point (Level 2) in a house is modest (\$1000-\$1500) in most cases and the cost is expected to decrease as more electrical contractors offer this service and become experienced in installing charging stations. Using a home charger permits the PEV owner to minimize the cost of electricity to charge the battery by optimizing the time-of-day for charging and the availability of the battery for grid management by the utility. Home charging will become even more attractive if/when the PEV chargers have a power of 10 kW.

### **1.7.2 Provision of multi-family (apartment) charging facilities**

At the present time, battery charging is very difficult for PEV owners living in multi-floor apartment buildings or other multi-family structures. Many of these buildings have outside or underground parking with unassigned parking places. In order to provide PEV battery charging, the owner of the building would have to install a number of charging points for use of his tenants. This would require a sizeable investment on the owner's part unless the chargers were installed by the electric utility. In that case, the owner could manage the chargers for the utility and recover the cost from the rent for the apartments from EV owners. Charges for the electricity could be added to the rent or billed separately. Situations in which the chargers are used by a known group of PEV owners should be manageable both from the economics and convenience points of view.



### **1.7.3 Provision of on-street charging facilities and public parking lots**

Many car owners presently park their vehicles on the street at night or in a public parking lot during the day. If this group of vehicle owners is expected to purchase PEVs, provisions will have to be made for them to charge the batteries in a reliable, timely manner. This will require the installation of charging points along streets and in parking lots much like parking meters. This could be done by the electric utilities and municipal utility districts and their contractors with the charger operations performed much like currently being done by Charge Point and other charger manufacturers. Reservations and information on the current cost of electricity could be done using cell phone apps. Installation of this type of charging facility is included in the proposed plans of the major utilities in California.

### **1.7.4 Provision of workplace charging**

Workplace charging [29-31] can have a large role in providing convenient charging for PEV owners without home charging and also provide electric utilities the opportunity for grid management through V2G control of charging times and powers. There are large numbers of vehicles parked routinely around most businesses and some of those parking areas could be converted to parking for PEVs. These chargers will be Level 2 chargers in most cases. The cost of the conversion could be paid by the business owner with some fraction of the cost being a tax credit or reimbursement by the government. The business owner could operate the charging facilities with the electricity charges being collected from the employees in total or in part as a fringe benefit. The electric utility could arrange with the business owner to control the charging at times that are mutually advantageous. In all cases, workplace charging has been part of the projects proposed and approved by the CPUC.

### **1.7.5 Construction of fast charging networks along major highways**

Sales of electric vehicles (EVs) will be limited unless the vehicle owners can use the vehicles for regional and inter-city travel requiring battery charging during the trip. In most cases, long periods of battery charging would not be acceptable and fast charging (charge times less than thirty minutes) would be expected. These fast charging stations would be located along highways used for inter-city travel at rest stops or regular stopping locations like stores, restaurants, etc. off the highways. As the electric range of the PEVs becomes longer and the battery capacity (kWh) is larger, the power required at the fast charging stations will become higher being in excess of 100 kW (ex. Tesla stations). These charging stations are expensive, require high electrical power, and initially likely not be heavily used. Hence to construct a network of fast charging stations will likely require a high degree of subsidies from a combination of EV manufacturers, electric utilities, and government. One problem with high power charging is the high demand charges of the utilities and most of the fast chargers require power greater than the demand charge limit. Discussions at the workshop indicated that at the present time, utilities are waiving these demand charges, but no long time solution was discussed.

As discussed in Sec 2.2.1, the technology for fast charging is still evolving increasing the financial risk of making large investments in a fast charging network at the present time. Tesla

has made a large investment in extensive networks in the United States and in other countries using charging hardware unique to their vehicles. Free access to their networks is part of the sales agreement when the Tesla EVs are purchased. The technology for fast charging must be standardized and networks similar to those being developed by Tesla made available to EVs from all manufacturers before high penetrations of EVs in the market can be expected. This may require some government intervention to require standardization for fast charging, especially for the connectors and safety interlocks. After standards are set, it can be expected that the cost of fast charging stations will start to decrease significantly.

### 1.7.6 Off-grid storage to decrease the effective cost of the electricity

Off-grid storage of the electrical energy to be used to charge the vehicle batteries in an on-site battery can reduce the effective cost of charging the batteries in several ways. First, solar electricity from PV panels can be stored during the day when EVs are not available for charging. This electricity can be relatively low cost. Second, it may not be convenient to charge the EV when the utility is offering low cost electricity and storage of the electricity for later use can be economically attractive. Thirdly, in the case of high power charging (>50 kW), demand charges can be afforded if all or part of the charging power is provided by previously stored electricity. As discussed in [34] at the workshop, products are being developed to store electricity on-site of the charger for both home and large-scale applications.

### 1.7.7 Special rates for electricity to charge the battery of PEVs

Some purchasers of EVs consider economics in making their purchase decision. In that case they compare the ownership cost of the EV with that of a comparable conventional gasoline fueled car. In most instances, the initial cost of the EV is higher and the energy cost per mile of the EV is lower. The EV buyer desires to recover the difference in the initial vehicle cost from savings in operating costs – energy and maintenance costs. The EV purchaser hopes to recover the initial vehicle cost difference in 3-5 years.

The cost of charging the battery depends on the cost of the charger and the price of the electricity (\$/kWh). For home charging, it is convenient to include the cost of the charger in the cost of the EV. What is favorable for EVs is a low electricity price and a high gasoline price. The ratio of the energy cost of the EV to that of the conventional car is

$$(\$/\text{mi})_{\text{elect.}} / (\$/\text{mi})_{\text{gasol.}} = ((\text{kWh}/\text{mi})_{\text{EV}} \times \$/\text{kwh}) / ((\$/\text{gal})_{\text{gasol.}} \times (\text{mpg})^{-1})$$

Consider the following example,

$(\text{kWh}/\text{mi})_{\text{EV}} = .25$ ,  $\$/\text{kwh} = .15$ ,  $(\$/\text{gal})_{\text{gasol.}} = 2.5$ , and  $\text{mpg}=30$ ,  
 $(\$.083/\text{mi})_{\text{gasol.}}$ ,  $(\$.0375/\text{mi})_{\text{elec}}$

For this case,  $(\$/\text{mi})_{\text{elect.}} / (\$/\text{mi})_{\text{gasol.}} = .45$  and the energy cost of the EV is about half that of the conventional vehicle. If the electricity price was only  $\$.075/\text{kWh}$ , the energy cost of the EV would be about one-fourth that of the gasoline fueled car. For the higher price of electricity, the energy cost saving would be  $\$455/\text{yr}$  for 10000 miles and for the lower price of electricity it would be  $\$645$ . In 5 years of operation of the EV, the energy cost savings would be  $\$2275$  and  $\$3225$ , respectively. In order for the economics of the EV to be favorable, it is clear that every

effort must be made to deliver the electricity to the chargers at a low price- probably less than \$.10/kWh unless the price of gasoline becomes \$3-\$4/gal. This low price for electricity may be difficult to meet in Level 2 public chargers. Dispensed electricity prices of \$.15-\$.20/kWh at public chargers were mentioned at the workshop.

### **1.7.8 Registration and tax incentives for PEVs**

One approach to reducing the cost of ownership for PEVs would be reduce the sales tax paid when a PEV is purchased and a charger is installed at the home and then reduce the registration fee paid each year. Registration fees tend to be high for PEVs because they are more expensive than conventional ICE cars. One advantage of reducing the registration fee is that it is paid each year and that advantage persists over the lifetime of the PEV.

## **References for Part I**

M.G, Richard, Tesla built 858 new public charging stations in the U.S. over the past 12 months, internet, November 30,2015

Baroody, L., CEC and Charging Infrastructure, Workshop on Critical Barriers and Opportunities for PEV Commercialization in California, University of California-Davis, April 26, 2016

Tony Market, Andrew Meintz, and Jeff Gonder, Dynamic wireless power transfer grid impacts analysis, EPRI EV IWC Meeting, Atlanta, GA. November 19, 2015.

T.W. Ching, Y.S. Wong, Review of Wireless Charging Technologies for Electric Vehicles, Power Electronics Systems and Applications (PESA), 2013 5th International Conference on, Hong Kong 11-13 Dec. 2013

[www.pluglesspower.com](http://www.pluglesspower.com)

<http://www.vox.com/2016/5/24/11677684/wireless-charging-electric-vehicles>

Peter Harrop, Khasha Ghaffarzadeh, Wireless Charging 2016-2026: Phones & Small Electronics, Electric Cars & Other Vehicles, Idtechex: [www.idtechex.com](http://www.idtechex.com)

<http://www.sae.org/news/3391/>

<http://www.gizmag.com/sae-wireless-charging-phev-j2954/43465/>

R. Sabbah, R. Kizilel, J.R. Selman, and S.Al-Hallaj, Active (air cooled) vs. passive (phase change material) thermal management of high power lithium battery packs: limitation of temperature rise and uniformity of temperature distribution, Journal of Power Sources 2008, 182 (2); 630-638

John P. Rugh, Ahmad Pesaran, kandler Smith, Electric vehicle battery thermal issues and thermal management techniques, SAE 2011 Alternative Refrigerant and System Efficiency Symposium, Scottsdale, AZ. September 27-29, 2011

Monu Malik, Ibrahim Dincer and Marc A. Rosen, Review on use of phase change materials in battery thermal management for electric and hybrid electric vehicles, *Int. J. Energy Res.* 2016; 40: 1011-1031

[www.allcelltech.com](http://www.allcelltech.com)

J. St.John, California utilities likely to be back in the EV charging business, November 18, 2014, from internet

California considers lifting ban on utilities owning EVSE, *Charged Electric Vehicles* magazine, November 18, 2014

R. Walton, How SDG&E wants to power the electric vehicle market, October 8, 2014, from the internet

Southern California Edison Charge ready program and market education program, \$355 Million, application to the CPUC, October 30,2014,

California regulators approve pilot EV Charging program for Southern California Edison, *Renewable Energy World* Editors, January 19, 2016

H.K. Trabish, CA regulators approve \$45M SDG&E electric vehicle charger rollout, February 1, 2016, from internet

J. Pyper, Regulators turn down PG&E \$654 Million EV-charging station, September 28, 2015, from the internet

J. St. John, Will PG&E finally get approval for its EV charging pilot? March 30, 2016, from the internet

2015 ZEV Action Plan (California), Governor's Interagency Working Group on Zero Emission Vehicles, April 2015 (draft)

Electric vehicle charging stations Tax credit fact sheet, updated 1-8-16, Federal Tax Credit DriveClean.ca.gov, summary of tax credits and incentives for electric vehicle charging stations in California

J. Ward, Non-Residential Vehicle Supply Equipment (EVSE) Costs, Workshop on Critical Barriers and Opportunities for PEV Commercialization in California, University of California-Davis, April 26, 2016

D. Chang, etals, Financial viability of non-residential electric vehicle charging stations, report by the UCLA Luskin Center, August 2012

J. Agenbroad and B. Holland, What is the true cost of electric vehicle charging stations?, Rocky Mountain Institute, May 2014

J. Francfort, D. Karner, and K. Morrow, Plug-in hybrid electric vehicle charging Infrastructure review, US Department of Energy Vehicle Technology Program report, 2008

Best practices for workplace charging, CALSTART, 2013

Plugging in at work: how to effectively install, share, and manage electric vehicle charging stations, Plug-in Electric Vehicle Collaborative report, November 2015

M. Nicholas and G. Tal, Charging for charging at work: Increasing the availability of charging through pricing, UCD-ITS-WP-13-02

[www.pluginamerica.org](http://www.pluginamerica.org)

Theodore Bohn, PEV Charging Standards Status Including AC, DC and Wireless Technologies, SAE Government & Industry Meeting, Jan 31, 2013.

Greencharge networks, presentation at the CEC EV Merit review, Sacramento, April 2016

# Part II: Infrastructure for commercial PEVs and transit buses

## 2.1 Electrification truck markets and technologies for MD/HD vehicles (HBZ/AFB)

Truck manufacturers are developing new electrified powertrain technologies for MD/HD trucks across a wide variety of applications. Some of these technologies are being commercialized, but the majority of them involve demonstrations of relatively small numbers of vehicles. Electric battery-powered transit buses in relatively small numbers (less than 100) are in commercial service, but these numbers are expected to increase rapidly in future years. There are presently several hundred medium-duty (MD) electric delivery trucks/vans in service in an early stage of commercialization.

Present demonstrations are often in niche markets where technology is matched to a particular application/customer. The vehicle markets include:

- Heavy-duty drayage (port)
- Heavy-duty long-haul
- Heavy-duty day cab
- Heavy-duty refuse
- Work-site utility
- Medium-duty delivery
- Transit and school buses
- The new technologies include:
  - Hybrid-electric powertrains
  - Battery-electric powertrains
  - Natural gas engines having ultra-low NO<sub>x</sub>
  - Fuel cell powered and hydrogen

The technologies that have been commercialized are natural gas engines in trucks and buses, hybrid-electric trucks and buses, and battery-electric transit buses. Many transit agencies operate a significant number of natural gas and hybrid-electric buses and are beginning to acquire electric battery-powered buses in relatively large numbers as well. The medium-duty delivery truck market includes a significant number of natural gas fueled and hybrid-electric vehicles. More recently, heavy-duty, long-haul natural gas trucks are being marketed.

The sales of battery-powered electric transit buses are booming worldwide [1], especially in China. In China in 2015, there were 112,296 certificates issued for electric transit buses. Sales of electric transit buses in California [2] and the United States [3] have increased steadily in recent years, but the volume of these sales is small compared to those in China. The operation of the electric buses will demonstrate the electric drive components needed to commercialize medium- and heavy-duty trucks in North America. Proterra, New Flyer, BYD, and others have

produced buses that are currently being operated by transit agencies. Most of these buses use lithium batteries, store 200-300 kWh of electrical energy and have ranges over 200 miles. Part II of the report is concerned with the development of the battery charging infrastructure needed to recharge the large battery packs in these MD/HD electric vehicles. This infrastructure on a large scale will be needed to meet the target set in the California Sustainable Freight Action Plan [4] (May 2016) to deploy over 100,000 freight vehicles capable of zero emission operation by 2030 with a high fraction of those vehicles using renewable energy.

## **2.2 MD/HD PEV vehicles in California and the United States—present and future**

The California Energy Commission (CEC) and the University of California-Davis (UCD) organized workshops [5] in December 2015 concerned with the status and future development of electric and hybrid technologies for MD/HD vehicles. Those workshops were intended to assess what the State of California and the United States government could do to accelerate the commercialization of emerging EV and HEV technologies for MD/HD transportation. The California Air Resources Board (CARB) staff recently published their technology assessment of MD/HD battery electric trucks and buses [6]. These two references contain detailed material on the both heavy-duty electrified powertrains and MD/HD vehicles that utilize these powertrains.

The materials presented in [5, 6] indicate that good progress is being made on the development of the heavy-duty powertrains and that there are numerous demonstrations of these powertrains in vehicles [7-10]. In most cases, the electrified powertrains are presently considerably more expensive than the engine-transmission components they replace and the onboard storage of electricity in batteries is much heavier and requires more volume than is the case of liquid fuels used in engines. It is expected that the energy density (Wh/kg and Wh/L) of batteries will continue to increase in future years [11] and their cost (\$/kWh) will continue to decrease [12] from the present value of about \$500/kWh to as low as \$150/kWh even for batteries suitable for use in MD/HD vehicles. At the present time, the cycle and calendar life of batteries in MD/HD applications is uncertain. Hence experience with heavy-duty powertrains and batteries in transit buses [13], which are being sold in relatively high volume, will provide valuable information concerning both the durability and cost of electrified powertrains in large freight vehicles. Further information on electrified MD/HD powertrains will be provided from planned demonstrations of MD/HD vehicles in California [14, 15] funded by the CEC.

Even for transit buses in the United States, the near-term/medium-term markets for electrified MD/HD are uncertain at the present time. A recent estimate of potential annual markets for MD/HD vehicles of various types in the United States has been made by TransPower [16], a developer of heavy-duty electric drive systems in California (see Table 1). These estimates are clearly approximate at best, but they do indicate the relative size of the markets for various types of vehicles and that the total market is of reasonably large (\$11 billion/yr). These markets are in addition to the expected large market for electric transit buses. None of these

markets can develop without an adequate cost-effective battery charging infrastructure for MD/HD vehicles.

**Table 1. U.S. potential markets – electric drive systems [x]**

Vehicle type	Units per year	Market value (\$/yr)
Port Drayage trucks	4,000	1,000 million
Refuse trucks	10,000	2,500 million
Local delivery trucks	20,000	5,000 million
Yard tractors/cargo equipment.	2,500	500 million
School buses	10,000	2000 million
<b>Total</b>	<b>46,500</b>	<b>11,000 million</b>

### 2.3 MD/HD charging infrastructure technologies and facilities

The infrastructure for charging batteries in light-duty vehicles is discussed in detail in Part I of this report. Most of the light-duty vehicles are owned by individuals who are responsible for making sure the batteries in their EVs are properly charged to meet their travel needs. The charge points for the light-duty vehicles are scattered throughout the communities including at the homes of many EV owners. The batteries in the light-duty EVs store less than 30 kWh except for those EVs having a range greater than 200 miles. In that case the batteries would store 60-80 kWh. Most of the battery chargers available are Level 2 with a power less than 10 kW except for a limited number of high power, fast chargers having a power of 50-120kW. The public charging stations are not owned by the people who own the EVs. As discussed in Part I, the charging infrastructure for the light-duty EVs is growing rapidly and is the subject of considerable government attention and support.

The situation for MH/HD electric vehicles is far different than is the case for light-duty EVs. In most cases, the MH/HD EVs are housed in commercial fleets of multiple vehicles with the charging facilities being provided by the owner of the fleet. There are only a relatively few MD/HD in use in 2016 and many of those vehicles are operated primarily for demonstration purposes. In the United States, this is even true of transit buses, which are in use in China in large numbers in many cities. As indicated in Table 2, there are a wide variety of MD/HD electric vehicles being developed for different applications. The battery size (kWh) in these vehicles varies by a considerable factor which will result in corresponding large variations in the charging power required. Except for delivery trucks, the batteries in the commercial EVs are much larger than those in light-duty EVs. Hence even for overnight charging (6-10 hr.), power



levels greater than Level 2 (19 kW) will be required for most MD/HD EVs. Level 3 DC chargers with powers of 50-120kW are presently available and would be suitable for overnight charging of most of the HD EVs. The fast charging stations built by Tesla [17] for their long range EVs would be capable of charging the HD EVs in 2-3 hours.

**Table 2. Characteristics of MD/HD electric vehicles for various applications**

Vehicle type	Range mi	Battery kWh	Motor kW	Charging kW*
Transit bus	150-200	300-350	200-250	60
School bus	50-75	80-100	150	20
Delivery truck	50-100	40-80	120	15
Port drayage truck	50-75	270	300	50
Refuse truck	60-80	220	230	40

\*full charge in 6 hr.

Charging the HD vehicles with 200-300 kWh battery packs present the most difficult problems. This is especially the case if it is desired to charge the batteries during the day in a 1-2 hours or less. This would require a Level 3 charger with a DC output power of 100-200 kW. Such chargers are becoming available commercially [18], but they are not yet common. The most readily available are 50 kW DC chargers. Another approach to the charging of the large battery packs is that taken by TransPower [19, 20] in their development of all-electric Class 8 vehicles. They utilize the motor inverter electronics to convert 208V, 3-phase AC to 400V DC, 70kW to charge a 215 kWh battery pack. This permits TransPower to charge the large battery in about 3 hours. When a 480V, 3-phase AC supply is available, a DC charging power of about 150kW will be provided by the TransPower charger.

## 2.4 Transit bus charging facilities including ultra-fast and wireless charging

There are two approaches in practice for charging electric transit buses. One approach is to charge the batteries of the buses at their home depot overnight. The chargers in this case are Level 3 DC chargers with powers between 50-120 kW, which is the same as the chargers used for fast charging light-duty EVs. These chargers can charge the large batteries in buses in 3-8 hours. The batteries in the buses are sized (kWh) to meet the range requirements for the routes on which the buses are used. All the BYD buses [21] are designed to use the Level 3 chargers. In this approach, the bus company has complete responsibility for and control of battery charging. The power requirements for the overnight, DC charging are relatively low per bus, but charging a fleet of buses would require high total power for the bus depot/garage.

The second approach to charging buses is to provide provision for fast charging the buses along their route. In this case, the charging is done in 5 minutes or less at stations along the route

from overhead, high power (500-600 kW) units (Figure 1) that dock with the bus at a stop and transfer DC power to charge the batteries. This approach permits the use of relatively small batteries (less than 100 kWh) onboard the bus which significantly reduces the purchase cost of the bus. There are two significantly different technologies available for the overhead charging stations. In North America, Proterra [22, 23] has developed charging units that employ a blade/socket arrangement that is insulated and enclosed for protection from the weather. Proterra has marketed this unit to a number of transit companies [24, 25] especially on the West coast [x-y] and it has functioned well. In the Foothill Transit demonstration [26, 27], 20 kWh is transferred to the 88 kWh battery pack in 5 minutes an average of 12 times per day as the bus runs its route. In Europe, ABB [28, 29] has supplied over 4000 DC fast charge, pantograph systems to bus companies. These are 400-800V, 450-600kW charging units with well-developed docking and interface communication protocols.



**Figure 1. Proterra bus overhead charging station**

Large numbers of electric transit buses are being sold world-wide using overnight chargers (ex. BYD) and overhead, fast charger. In both cases, standards for the connectors and chargers are not in place, but in both cases, discussions between the various stakeholders are underway because the need for standards is widely recognized [30, 31]. To further complicate, the electric bus charging situation, progress [32, 33] is being made on the development of wireless charging technology that could be used for transit buses. Wireless charging could even be installed along/under roads to charge transit buses in route.

## **2.5 Costs of MD/HD charging facilities**

There are presently in-service and demonstration fast charging stations for MD/HD, including for transit buses in North America, Europe, and China. These stations have been built by/for Tesla, Proterra, and ABB. The bus fast charging stations charge the batteries in about 5 minutes. Slow charging station hardware is commercially available primarily from fast charging in light-duty vehicle applications. The main difficulty in providing fast charging for heavy-duty

vehicles and buses is to have available the high power service (MW in some cases) needed to charge multiple vehicles. There is not much information available concerning the cost of the fast charging stations for MD/HD applications. Recent reports [34, 35] by Energy+Environmental Economics (E3) included information on the cost of providing charging stations for MD/HD vehicles. The cost projections shown in Table 3 were taken from [35]. The cost information from E3 project significant reductions in the cost of charging stations from 2015-2030. The initial costs for fast chargers are much higher than for slow chargers, but since the time per charge is much less for fast charging, the business case for fast charger will be more attractive than for slow chargers when the numbers of battery-powered vehicles are large enough to keep the fast charging stations busy a large fraction of the time. The cost of the electricity and related demand charges will be important consideration [35] in evaluating the economics of fast charging of HD vehicles.

**Table 3. Costs of charging stations taken from [35]**

Charger and Vehicle type	Battery size (kWh)	Operating life	Cost (\$) per charging			
			2015	2020	2025	2030
MDV/LDV Slow (6.6 kW)	46	20	5250	3829	3442	3222
MHD Slow (19 kW)	125	20	25,000	18235	16389	15343
HHD Slow (40 kW)	304	20	35,000	25530	22945	21480
Bus Slow (80 kW)	324	20	50,000	36471	32779	30686
Bus Fast (240 kW) 5 Veh./charger	324	20	1,500,000	1,094,124	983,360	920,572

## **2.6 Future requirements for MD/HD charging (buses, Ports, warehouses, etc.)**

### **2.6.1 Power requirements and charging facility characteristics**

For most HD vehicle applications, the size of the batteries to be charged will be large (100-300 kWh) and the power to recharge the battery pack even for a slow charge will be relatively high (50- 200 kW). Hence for a fleet of electric HD vehicles the peak power requirements for the charging facility will be at least several MW. For slow charging, the battery charging will be done overnight so the cost of the electricity should be relatively low and the demand charges not a problem. As indicated in Table 3, the cost of the individual vehicle chargers will be \$30-40K in the future.

Present indications are that fast charging of HD trucks and transit buses will take place only using overhead charging stations. These stations utilize very high power (400-600 kW) and are utilized during the day in many cases. Hence the cost of the electricity will be high and demand charges can be a problem. Fast charging is used because the effective range of the HD vehicle can be long using a relatively small battery (<100 kWh). This will reduce the initial cost of the electric HD vehicle and bring its cost much closer to that of a comparable diesel or natural gas fueled vehicle. The life of the smaller battery could be a problem due to fast charging, the high power demanded by the electric traction motor, and the frequent relatively deep discharges.

### **2.6.2 Construction and management of the charging facilities for various applications**

There will be several business arrangements for providing battery charging for MD/HD electric vehicles in commercial service. Construction of the charging stations and supply of the charger hardware will be provided by companies with special expertise. The ownership of the stations and their operation can be done by specialty companies in the business of battery charging station operation or by the primary user of the facility. It is likely that slow charging facilities for fleets of commercial electric vehicles will be owned and operated by the vehicle operators who will also maintain the vehicles. Purchasing the charging stations and contracting with the utilities for the electricity will be part of the business case for the use of the electric vehicles.

There are situations, such as at the ports of Los Angeles and Long Beach, where there could be many HD electric or plug-in hybrid vehicles owned and operated by several different companies. In this case, a public charging station would be needed that would handle batteries of different voltage and size. It would be similar to the public charging stations for light-duty vehicles, but be able to charge large batteries. These charging stations could be privately owned and operated or build with public money and operated as a private business.

### **2.6.3 Possible role for the utilities as power stations**

As discussed in previous sections, the power requirements for charging batteries in HD vehicles can be high. Installation of the electrical service to the charging facility will be handled by the electric utility in the area. In some cases, it may even be necessary for the utility to establish a special sub-station to provide the power to the charging station. HD vehicle charging will likely

require 480V-3 phase service. Hence the primary role of the electric utilities will be make sure they have the capacity (MW) to provide the high power required to charge HD vehicles.

## **2.7 Ways of reducing the cost of the charging for MD/HD applications**

### **2.7.1 Providing standard designs and hardware**

At the present time, there is little standardization of vehicle connectors for high power DC chargers or docking systems for overhead fast charging of electric transit buses or trucks. This problem is widely recognized world-wide and there are meetings [30, 31] underway to set the needed standards. High power charging units are being manufactured in various countries and have been used successfully in HD vehicle demonstrations and small scale commercialization projects. If the appropriate electrical power is available, it appears that suitable charging units can be purchased for almost any HD electric vehicle project under consideration. Well documented standards are needed before large investments in providing HD vehicle charging hardware at reduced cost will be made.

### **2.7.2 Funding for MD/HD charging facilities**

There are multiple funding sources, both Federal and California, for electric MD and HD battery electric vehicles. These sources offer large incentives for the purchase of the vehicles which can include the cost of the charging infrastructure. In the case of transit buses, the Federal Transit Administration (FTA) has competitive grants that cover 80% of the cost of new bus purchases including battery electric buses. The fiscal 2016 Low or No Emissions Bus program [36] of FTA funded \$55 Million of electric bus purchases. Many of these projects cited the inclusion of battery charging and in a number of them enroute overhead fast charging was cited. The California HVIP [37] also includes incentives for the purchase of battery-powered trucks and bus, but the incentives are modest. For example, the maximum incentives for transit buses are about \$100K. These funds can be used to provide charging facilities. Another large funding source in California for advanced clean trucks is the \$500 million Low Carbon Transportation and Fuels Project. ARB has proposed to use some of those funds for electric trucks and buses [35]. CEC also funds charging stations for commercial applications [38].

It is critical that the various funding sources be maintained at high levels into the future so that electric truck and bus markets will continue to grow. This will increase the demand for battery charging facilities and decrease their cost.

### **2.7.3 Organization of charging facility companies**

There are companies whose primary business is providing charging for light-duty electric vehicles [39, 40]. There is also a need for companies who specialize in providing high power charging facilities for MD/HD electric vehicles. This would reduce the cost of the charging facilities and likely lead to the more rapid setting of standards for them. This need applies to both depot/garage based slow charging and overhead fast charging facilities.

#### **2.7.4 Tax credits for high power, HD charging facilities/companies**

Another approach to reducing the cost of installing battery charging infrastructure for MD/HD vehicles is a tax credit based on cost of the vehicle charging station. There have been a number of tax credits available in recent years especially Federal Tax credits. Most of those tax credits have been for home battery chargers for light-duty electric vehicles. An example [41] is the tax credit included in the Fixing America's Surface Transportation Act (FAST). That act has a tax credit for personal and business use battery charging stations. For personal use, the tax credit is the smaller of 30% of the station cost or \$1000. For business use, the tax credit is the smaller of 30% of the cost of the station or \$30,000. The tax credits expire on December 31, 2016.

It has been common for tax credits to be available for a specific time period and then expire. The tax credit approach is a good way to encourage businesses that are willing to invest in electric trucks and need a small improvement on the cost side of their business plan to make a final commitment.

#### **2.7.5 Special electricity rates from utilities for MD/HD charging, including demand charges**

The energy costs (electricity) associated with the operation of MD/HD electric vehicles are significantly less than for vehicles using gasoline or diesel fuel. The present higher initial costs of the electric vehicles can be off-set by lower energy and maintenance costs. To encourage the adoption of electric trucks and buses, it is important that the electricity cost be as low as possible. The utilities can make the business case for electric vehicles more attractive by offering low off-peak rates for depot/garage-based slow charging and mitigating possible demand charges for daytime charging [42] with the enroute overhead fast charging stations.

## References for Part II

- C. Kailasam, Strategic Analysis of the Global Hybrid and Electric Heavy Duty Transit Bus Market, Frost & Sullivan, October 2013
- Advanced Clean Transit, California Air Resources Board presentation, May 2015
- Race to Zero Emissions, Who's operating zero emission buses? Status of the deployment of electric transit buses in America and China
- California Sustainable Freight Action Plan, July 2016 Pp
- Workshop on Emerging Medium- and Heavy Duty Vehicle Technology Markets- Barriers and solutions, University of California-Davis, December 3, 2015
- Technology Assessment: Medium- and Heavy-Duty Battery Electric Trucks and Buses, Air Resources Board Report (draft), October 2015
- J. Voelcker, FedEx tests Wrightspeed Electric trucks with diesel turbine range extender, October 14, 2014
- TransPower announces new heavy duty electric vehicle accomplishments, San Diego, March 25, 2015
- EV International, Press releases-Our latest activities, 2016
- C. De Morro, Motiv delivers first electric garage truck to Chicago, /September 16, 2014
- K. Smith, S. Santhanagopalan, A. Pesaran, and K. Kelly, Battery technologies for heavy duty electric vehicles, August 19, 2015
- Medium and Heavy-duty Battery Electric Vehicle- Technology Assessment, ARB presentation, September 2, 2014, Sacramento, California
- Jing-Quan Li, Battery Electric Transit Bus Developments and Operation, International Journal of Sustainable Transportation, 10:3, 157-169, August 2014
- K. Johnson, J. W. Miller, and J. Yu, Performance Evaluation of a Second Generation All-Electric Yard Tractor (TransPower, report prepared by University of California-Riverside, April 2015
- U. Nagrani, Central Valley Electric School Bus Demonstration Project, report prepared by Motif Power Systems, June 2014
- M. Simon, Adaption of Common, Modular Electric Drive System Elements to Class 8 Port Trucks, Yard Tractors, and School Buses, presentation at the California Energy Commission Merit Review, Medium and Heavy duty Vehicle Project Successes, December 2, 2015
- Tesla-Supercharger, [w.w.w.tesla.com/en\\_GB/supercharger](http://w.w.w.tesla.com/en_GB/supercharger)
- D. Andersson and D. Carlson, Measurements of ABBs Prototype Fast Charging Station for Electric Vehicles, report prepared by Chalmers University of Technology, Gothenburg, Sweden, 2012

K. Johnson, J. W. Miller, and J. Yu, Performance Evaluation of TransPower All-electric Class 8 On-road Truck, report prepared by University of California-Riverside, April 2015

EPIC 150, Inverter/Charger Unit (ICU), TransPower, 2015

BYD Motors Wins America's Largest Electric Bus Order, Olympia, Washington, September 4, 2015

C. Ruoff, The Inevitability of Electric Buses, Charged Magazine, Issue 26, pg 40-51, July/August 2016

M. Kane, Proterra opens electric bus fast charging Technology

L. Ottaway, Electric bus manufacturers BYD and Proterra are making serious moves, July 22, 2014

C. Ruoff, The Economics of the Electric Business (Proterra CEO Ryan Pople), Charged Magazine, July 2015

L. Eudy, R. Prohaska, K. Kelly, and M. Post, Foothill Transit Battery electric Bus Demonstration Results, Technical report NREL/TP-5400-65274, January 2016

R. Prohaska, L. Eudy, and K. Kelly, Fast charge Battery Electric Transit Bus In-Use fleet Evaluation, paper presented at the ITEC 2016, IEEE Transportation Electrification Conference, June 2016

ABB launches robotic fast charging system for electric buses, October 22, 2015

ABB and Volvo form global partnership for electric and hybrid fast charging, Zurich, Switzerland, July 21, 2014

SAE International, Vehicle Electrification Standards

J. Ayre, Opbrid Busbaar backing open standards for overhead electric bus charging stations, June 19, 2015

A. Gruzen. Wireless Charging and Autonomous Vehicles will mobilize the Smart City, Charged Magazine, Issue 26, pg 78-81, July/August 2016

C. Morris, Antelope Valley Transit Authority buys WAVE wireless charging system, Charged Magazine, June 2016

California Transportation Electrification: Phase 2 : Grid impacts, report prepared by Energy +Environmental Economics, October 23, 2014

California Transportation Electrification: Phase 3-Part A : Commercial and non-road impacts-Final report, prepared by Energy +Environmental Economics, January 2016

U.S. Department of Transportation announces \$55 Million in grants to Transit agencies to deploy clean buses, includes list of the Fiscal year 2016 Low or no emissions bus program projects, July 2016

HVIP Hybrid Truck and Bus Voucher Incentive Program – Implementation Manual, Air Resources Board, 2009



Proposed Fiscal year 2016-17 Funding Plan for Low Carbon Transportation and Fuels  
Investments and Air quality Improvements Program, Air Resources Board, June 2016

ChargePoint charger network, [www.chargepoint.com](http://www.chargepoint.com)

GE uses AI to charge electric cars without running up the bill, Dec 15, 2014

Electric Vehicle Charging Stations Tax Credit Fact Sheet, updated January 8, 2016

JB. Gallo, TB. Rubin, and J. Tomic, Peak Demand Charges and Electric Transit Buses, Prepared by  
CALSTART for the U.S. Department of Transportation (FTA), November 2014

# Appendix I. Agenda and Attendees for April 26, 2016 workshop at UC Davis



## *STEPS Workshop: Critical Barriers and Opportunities for PEV Commercialization in California*

### *Infrastructure for Light-Duty Vehicles, Freight, and People Movement*

April 26, 2016

8:45am - 5:00pm, with reception to follow

[The ARC \(Activities and Recreation Center\)](#) Ballroom, UC Davis

The [California Energy Commission \(CEC\)](#) and [UC Davis Institute of Transportation Studies \(ITS-Davis\)](#) will conduct joint workshops on April 25 and 26, 2016 with a goal to:

- **Present and discuss insights on the status of PEV infrastructure in California, critical barriers, and recommendations to accelerate commercialization.**

This April 26 workshop at UC Davis is hosted by the [Sustainable Transportation Energy Pathways \(STEPS\)](#) team, with funding generously provided by the CEC and US DOE:



U.S. DEPARTMENT OF  
**ENERGY**

Funding for this research was generously provided by the CEC, through the [National Center for Sustainable Transportation](#).

Thank you to all of our sponsors, presenters, and stakeholders at today's workshop.

8:45 – 9:00	<b>Registration &amp; coffee</b>
9:00 – 9:15	<p><b>Welcome and Introduction:</b> Workshop objectives and overview of the day</p> <ul style="list-style-type: none"> <li>○ <i>Janea Scott</i>, Commissioner, California Energy Commission</li> <li>○ <i>Tyson Eckerle</i>, Deputy Director, ZEV Infrastructure, GOBiz</li> <li>○ <i>Paul Gruber</i>, Executive Director, STEPS Program, ITS-Davis</li> </ul>
9:15 –11:15	<p><b>Session 1: Electrification of <i>Light Duty Transportation</i> in California</b>  <b>Assessment and critical barriers to meet current and future PEV infrastructure needs</b>  Facilitator: <i>Paul Gruber</i></p> <ol style="list-style-type: none"> <li><b>1. Present status of PEV infrastructure: markets, stakeholders, and needs through 2025-2030</b> <ul style="list-style-type: none"> <li>○ <i>Mike Nicholas</i>, Researcher, PH&amp;EV Center, ITS-Davis (15 min)</li> </ul> </li> <li><b>2. The role of infrastructure in PEV adoption</b> <ul style="list-style-type: none"> <li>○ <i>Gil Tal</i>, Researcher, PH&amp;EV Center, ITS-Davis (10 min)</li> </ul> </li> <li><b>3. PEV infrastructure: background, technologies and costs</b> <ul style="list-style-type: none"> <li>○ <i>David Greene</i>, Senior Fellow, Howard H. Baker, Jr. Center of Public Policy University of Tennessee (5 min)</li> <li>○ <i>Jake Ward</i>, Program Manager, US DOE (10 min)</li> </ul> </li> <li><b>4. Market dynamics: players, roles, and profitability</b> <ul style="list-style-type: none"> <li>○ <i>Jamie Hall</i>, Manager, Advanced Vehicle and Infrastructure Policy, General Motors (10 min)</li> <li>○ <i>Colleen Quinn</i>, VP Government Relations, ChargePoint (10 min)</li> </ul> </li> <li><b>5. Electric utility perspective on PEV infrastructure requirements</b> <ul style="list-style-type: none"> <li>○ <i>Dean Taylor</i>, Principal Advisor, Air and Climate Group, Southern California Edison (10 min)</li> </ul> </li> <li><b>6. State government: policies, planning, and incentives</b> <ul style="list-style-type: none"> <li>○ <i>Leslie Barody</i>, Senior Light-Duty EV Infrastructure Specialist, California Energy Commission (10 min)</li> </ul> </li> <li><b>7. From idea to action: Readiness planning and implementation activities across the state</b> <ul style="list-style-type: none"> <li>○ <i>Phil Sheehy</i>, Technical Director, ICF International (10 min)</li> </ul> </li> </ol> <p>Q&amp;A/Comments after each presentation</p>
11:15 – 12:15	<p><b>Session 2: Electrification of <i>Freight and People Movement</i> in California</b>  Assessment of infrastructure needed and barriers to commercialization  Facilitator: <i>Sam Lerman</i>, Air Resources Engineer, California Energy Commission</p>

	<p><b>1. California’s objectives and progress on Sustainable Freight, market and stakeholders (10 min)</b></p> <ul style="list-style-type: none"> <li>○ <i>Sydney Vergis</i>, Manager, Goods Movement Program Section, CARB</li> </ul> <p><b>2. Panel: Electrification of freight (trucks, ports) (30 min)</b></p> <ul style="list-style-type: none"> <li>○ <i>Marshall Miller</i>, Senior Development Engineer, UC Davis</li> <li>○ <i>James Burns</i>, CSO, TransPower</li> <li>○ <i>Michael Coates</i>, CEO, Mightycomm</li> </ul> <p><b>3. Panel: Electrification of buses (20 min)</b></p> <ul style="list-style-type: none"> <li>○ <i>Seamus McGrath</i>, Manager - Charging Systems, Proterra</li> <li>○ <i>Urvi Nagrani</i>, Director of Marketing &amp; Business Development, Motiv Power Systems</li> <li>○ <i>Marcus Alexander</i>, Manager, Vehicle Systems Analysis, EPRI</li> <li>○ <i>Lisa McGee</i>, Operations Manager, San Diego Airport Parking Company</li> </ul> <p>Q&amp;A/Comments after each section</p>
12:15 – 1:15	Lunch
1:15 – 2:30	<p><b>Session 3: Ideas and solutions to overcome barriers for providing charging for PEV <i>Freight and People Movement</i></b></p> <p><b>Panel Discussion Topics: Accelerating PEV freight and people movement in California</b> Facilitator: <i>Sam Lerman</i></p> <p><b>1. Ways to accelerate electrified freight and people movement</b></p> <ul style="list-style-type: none"> <li>○ <i>Urvi Nagrani</i>, Director of Marketing &amp; Business Development, Motiv Power Systems</li> <li>○ <i>James Burns</i>, CSO, TransPower</li> <li>○ <i>Dedrick Roper</i>, Grant Operations and Public Policy Manager, ChargePoint</li> <li>○ <i>Seamus McGrath</i>, Manager - Charging Systems, Proterra</li> <li>○ <i>Vincent Wiraatmadja</i>, Associate Attorney, Weideman Group, Inc.</li> <li>○ <i>Don Anair</i>, Research and Deputy Director, Clean Vehicles Program, Union of Concerned Scientists</li> <li>○ <i>Michael Coates</i>, CEO, Mightycomm</li> </ul> <p>Q&amp;A/Comments after this panel</p>
2:30 – 4:45	<p><b>Session 4: Ideas and solutions to overcome barriers for providing charging for PEV <i>Light Duty Transport</i></b></p> <p><b>Panel Discussion Topics: Accelerating PEV transportation in California</b> Facilitators: <i>Tim Olson</i>, Manager, Transportation Energy Office, and <i>Paul Gruber</i></p>

	<ol style="list-style-type: none"> <li><b>1. Better: Improving utility capabilities in rollout of infrastructure (20 min)</b> <ul style="list-style-type: none"> <li>○ <i>Scott Briasco</i>, Manager of Electric Transportation, Los Angeles Department of Water and Power</li> <li>○ <i>Ralph Troute</i>, PM Electric Transportation, SMUD</li> <li>○ <i>Greg Haddow</i>, Clean Transportation, San Diego Gas &amp; Electric Co.</li> </ul> </li> <li><b>2. Cheaper: Reducing burden to consumers, reducing cost of infrastructure, getting the price right (30 min)</b> <ul style="list-style-type: none"> <li>○ <i>Kitty Adams</i>, Executive Director, Adopt a Charger</li> <li>○ <i>Kapil Kulkarni</i>, Marketing Associate, Burbank Water and Power</li> <li>○ <i>Lin Khoo</i>, Senior VP of Strategy, Greenlots</li> <li>○ <i>Claire Dooley</i>, EV Service Product Manager, NRG EVgo</li> <li>○ <i>David Hughes</i>, VP Government, EV Connect Inc.</li> </ul> </li> <li><b>3. More: Expanding market to those without reliable charging access and to new geographies (30 min)</b> <ul style="list-style-type: none"> <li>○ <i>Joel Pointon</i>, Principal, JRP Charge, Multi-Unit Dwelling Vehicle Charging Consulting</li> <li>○ <i>Matthew Marshall</i>, Executive Director, Redwood Coast Energy Authority</li> <li>○ <i>John Kalb</i>, Founder, EV Charging Pros</li> <li>○ <i>Stacey Reineccius</i>, CEO, Powertree Services Inc.</li> </ul> </li> <li><b>4. Emerging: Gamechanger technologies and trends (30 min)</b> <ul style="list-style-type: none"> <li>○ <i>Paul Stith</i>, Solution Lead, Smart Integrated Infrastructure, Black &amp; Veatch</li> <li>○ <i>Mike Nicholas</i>, Researcher, PH&amp;EV Center, ITS-Davis</li> <li>○ <i>Bob Wimmer</i>, Director, Energy and Environmental Research Group, Toyota</li> <li>○ <i>Jeremy Whaling</i>, Grid Connected Projects Manager, Honda</li> </ul> </li> <li><b>5. Better: Improving governmental role in rollout of infrastructure (20 min)</b> <ul style="list-style-type: none"> <li>○ <i>John Shears</i>, Research Coordinator, The Center for Energy Efficiency and Renewable Technologies</li> <li>○ <i>Joanna Gubman</i>, Advisor to Commissioner Carla Peterman, CPUC</li> <li>○ <i>Gil Tal</i>, Researcher, PH&amp;EV Center, ITS-Davis</li> </ul> </li> </ol> <p>Q&amp;A/Comments after each section</p>
4:45	<b>Wrap-up and recommendations</b> <ul style="list-style-type: none"> <li>○ <i>Roland Hwang</i>, Director, Energy &amp; Transportation Program, NRDC</li> <li>○ <i>Tyson Eckerle</i>, GOBiz</li> <li>○ <i>Tim Olson</i>, CEC</li> </ul>
5:00 – 7:00	<b>Reception at The Graduate</b> 805 Russell Blvd, Davis, CA 95616

## Sustainable Transportation Energy Pathways Program (STEPS)

[www.steps.ucdavis.edu](http://www.steps.ucdavis.edu)

STEPS is the major multidisciplinary research consortium within the Institute of Transportation Studies at the University of California, Davis. The consortium is comprised of 40+ PhD-level faculty and researchers and graduate students from UC Davis, 25+ industry and governmental partners, and 20+ outside expert organizations. Our mission encompasses:

- Research: generate new insights and tools to understand the transitions to a sustainable transportation energy future for California, the US and the world,
- Outreach: disseminate valued knowledge and tools to industry, government, the environmental NGO community, and the general public to enhance societal, investment, and policy decision making,
- Education: train the next generation of transportation and energy leaders and experts.

The STEPS 2015-2018 program is generously supported by these sponsors:

- Auto: BMW, Cummins, Daimler, Ford, Fiat Chrysler, GM, Honda, Renault, Toyota, Volkswagen
- Energy: Aramco, Centre for High Technology (India), Chevron, Shell, San Diego Gas & Electric/SoCal Gas Co., Sinopec
- Government: California Air Resources Board, California Energy Commission, Caltrans, South Coast AQMD, U.S. DOE, U.S. DOT, U.S. EPA

Our program areas and overarching research questions are:

- Initiating Transitions 2015-2030: What is required for early alternative fuel/vehicle transitions to succeed?
- The Future of the Fuels and the Oil & Gas Industry: How will changing geopolitical landscapes and disruptive technology in the oil and gas and clean technology industry impact future business models and the competition of fuels?
- Global Urban Sustainable Transport (GUSTo): How will a rapidly urbanizing world affect demand for transport and energy? How can we transition to sustainable transportation in a rapidly urbanizing world with ever-growing need for mobility?
- Modeling Analysis, Verification, Regulatory and International Comparisons (MAVRIC): What do improved and cross-compared economic/environmental/ transportation/energy models tell us about the future of sustainable transportation?

[What is the Sustainable Transportation Energy Pathways program?](#)



[Why sponsors value the UC Davis STEPS program:](#)



## Appendix II. Questions for April 26, 2016 Workshop

### **PEV Infrastructure for Light Duty Transport in California (Sessions 1 and 4)**

Assessment of infrastructure needed, barriers, and ideas/solutions to accelerate commercialization of PEV infrastructure for LDVs:

#### Status

1. What is the status of PEV infrastructure in California?
2. Why is charging important for PEV adoption?
3. What are the current and projected growth rates of PEV infrastructure?
4. How much infrastructure is needed, and by when? How can infrastructure be built out in a timely manner?
5. What types of charging are important? For which types of vehicles? For which types of consumers?
6. What are current and emerging PEV infrastructure technologies and business models?
7. What is a feasible business case for public charging stations for both slow and fast charge?
8. What current and potential revenue streams are EVSE developers and operators pursuing, and how significant are each to future business growth (e.g., subscriptions, advertising, electricity/time usage fees, LCFS credits, etc.)?
9. What are the total costs for installing PEV infrastructure? What are the cost trends? Which components can achieve larger cost reductions?
10. With fast charging, what is the best battery size (kWh) and vehicle range from the driver convenience and economic points-of-view?
11. How is the PEV infrastructure market (players, roles, business models, profitability) changing?
12. What will be the role of the electric utilities and local governments in expanding public charging infrastructure?
13. How do credits play into PEV infrastructure commercialization?
14. How will the charging infrastructure be provided in the future if the market penetration of EVs grows from 3% to 25% to 50%?

### Barriers/Solutions

15. What are the barriers for further development of PEV infrastructure in the state?
16. How can rollout be made more efficient, from readiness planning through implementation?
17. How can the burden to consumers of charging be reduced?
18. How can costs to the consumer be reduced?
19. How can charging infrastructure be deployed to people without good access to chargers (e.g., in Multi unit dwellings, suburbs, rural areas)? What are the price differentials for different EVSE technology/installation options, and what are the greatest potential areas for cost reductions?
20. How can PEV infrastructure markets be expanded in the state?
21. What are game changer technologies and trends that we should be factoring into planning now?
22. How can total cost be embedded and stay within consumer budgets? What innovative cost structures can be provided, if necessary?
23. What are some creative ways to spur the market? What are automakers looking into that may change the paradigm?
24. What more can government do to help spur PEV infrastructure development to lead to more PEV adoption?
25. What role can/should government policy have in determining profitability?
26. How will the cost of infrastructure, needed to influence EV sales, be paid while market penetration increases? At what costs are incentives still needed, and for how long? (When should government incentives phase out?)



## **PEV Infrastructure for Freight and People Movement in California (Sessions 2 and 3)**

Assessment of infrastructure needed, barriers, and ideas/solutions to accelerate commercialization of PEV infrastructure for freight and people movement:

### Status

1. What is the present status of PEV charging stations for MD-HD electric vehicles in California?
2. What are the state's goals in terms of sustainable freight and people movement?
3. What is the vehicle technology mix envisioned for sustainable freight in California? How important will electrification be?
4. Who is providing the hardware and stations, and who is owning and operating them? Is there interest among *light duty* charging manufacturers to develop products for non-light duty vehicles?
5. What are the charging requirements for the various types and sizes of MD-HD electric vehicles for the different applications?
6. What are the total costs for installing EV chargers in various non-light duty platforms, including bus, package delivery, drayage etc.? Discuss costs for equipment, installation, panel/transformer upgrades, and operational costs, including demand charges, and any projections on future costs.
7. What are cost trends for this infrastructure? How do we envision costs coming down over the next 5 – 10 years? For which components do we see larger opportunities for cost reduction?
8. How much of PEV infrastructure components is manufactured in CA vs. out of state?
9. How much of the infrastructure will be private vs. public for different applications?
10. Can there be a mix of light-duty and MD-HD charging infrastructure at a single public location?
11. How do credits play into PEV infrastructure commercialization?

## Barriers/Solutions

12. Is battery charging presently a barrier to the introduction of PEVs for freight and people movement?
13. What is the status of standards being developed for non-LDV platforms such as bus and port vehicles? Is there an emerging need to develop standards for other non-light duty platforms (drayage, refuse, delivery truck etc.)? Can these standards build upon existing standards for light duty (J1772) or build upon emerging standards for bus? Should all vehicle platforms conform to the same standards?
14. How will large-scale MH-HD EV infrastructure affect the grid? Are there electric utility constraints to the installation of battery charging facilities for high power commercial applications?
15. Are there standardized products (charging systems) becoming available for sale that meet the needs of high power charging facilities?
16. What changes need to happen in the private sector to expand deployment of infrastructure for non-light duty EVs?
17. What are game changer technologies and trends that we should be factoring into planning now?
18. How can government better support deployment of EV infrastructure in non-light duty platforms? Is there a potential role for EV infrastructure vouchers to complement HVIP?
19. How can government and industry work complementarily to support the development or adoption of new standards? When and how should standards organizations (SAE) be engaged?
20. What more can government do to facilitate PEV infrastructure rollout for non-LDVs? What incentives and programs are most useful now, and what new types are needed?
21. At which stage(s) would government incentives phase out?

## Appendix III. Attendees of April 26 workshop

### Attendees at UC Davis, “Critical Barriers and Opportunities for PEV Commercialization in California: Infrastructure for Light-Duty Vehicles, Freight, and People Movement”

<b>First Name</b>	<b>Last Name</b>	<b>Job Title</b>	<b>Company/ Organization</b>
Eric	Cahill	President	<b>Adaptiv Consulting</b>
Kitty	Adams	Executive Director	<b>Adopt a Charger</b>
Marc	Geller	Project Manager	<b>Adopt a Charger</b>
Peter	Ward	Principal	<b>Alternative Fuels Advocates</b>
Tom	Baloga	Senior Director, Government Affairs	<b>Audi of America</b>
Wafaa	Aborashed	Director	<b>Bay Area Healthy 880 Communities</b>
Paul	Stith	Solution Lead, Smart Integrated Infrastructure	<b>Black &amp; Veatch</b>
Rob	Glen	Commercial Director	<b>Bloomberg New Energy Finance</b>
Alejandro	Zamorano	Transport Specialist	<b>Bloomberg New Energy Finance</b>
Jim	Boyd	Principal	<b>Boyd Consulting</b>
Kapil	Kulkarni	Marketing Associate	<b>Burbank Water and Power</b>
Hannah	Goldsmith	Project Manager	<b>CaIETC</b>
Eileen	Tutt	Executive Director	<b>CaIETC</b>
Gerhard	Achtelik	Manager, Zero Emission Vehicle Infrastructure	<b>California Air Resources Board</b>
Marijke	Bekken	Staff Air Pollution Specialist	<b>California Air Resources Board</b>
John	Gruszecki	Staff Air Pollution Specialist	<b>California Air Resources Board</b>
Elise	Keddie	Manager, ZEV Implementation	<b>California Air Resources Board</b>
Ziv	Lang	Air Resources Engineer	<b>California Air Resources Board</b>
Paul	Milkey	Staff Air Pollution Specialist	<b>California Air Resources Board</b>
Stephanie	Palmer	Air Resources Engineer	<b>California Air Resources Board</b>
Mark	Siroky	ARE	<b>California Air Resources Board</b>

Mike	Sutherland	Supervisor	<b>California Air Resources Board</b>
Maria	Vacaru	Air Resources Engineer	<b>California Air Resources Board</b>
Sydney	Vergis	Manager, Goods Movement Program Section	<b>California Air Resources Board</b>
Melanie	Zauscher	Air Pollution Specialist	<b>California Air Resources Board</b>
Adeel	Ahmad	Air Resources Engineer	<b>California Energy Commission</b>
Jennifer	Allen	Energy Commission Supervisor	<b>California Energy Commission</b>
Leslie	Baroody	Senior Light-Duty EV Infrastructure Specialist	<b>California Energy Commission</b>
Kadir	Bedir	Specialist, EV Infrastructure	<b>California Energy Commission</b>
Rhetta	deMesa	Advisor to Commissioner Janea A. Scott	<b>California Energy Commission</b>
Brian	Fauble	Associate Energy Specialist	<b>California Energy Commission</b>
Sam	Lerman	Air Resources Engineer	<b>California Energy Commission</b>
Thanh	Lopez	Air Pollution Specialist	<b>California Energy Commission</b>
Tim	Olson	Manager, Transportation Energy Office	<b>California Energy Commission</b>
Matt	Ong	Energy Analyst	<b>California Energy Commission</b>
Sharon	Purewal	Associate Energy Specialist	<b>California Energy Commission</b>
Larry	Rillera	Senior Advanced Vehicle Technologies	<b>California Energy Commission</b>
Janea A.	Scott	Commissioner	<b>California Energy Commission</b>
Lindsee	Tanimoto	EV Team Lead	<b>California Energy Commission</b>
Sarah	Williams	Commission Specialist 1	<b>California Energy Commission</b>
Lindsee	Zhu	Air Pollution Specialist	<b>California Energy Commission</b>
Peter	Klauer	Smart Grid Solutions Manager	<b>California ISO</b>
Joanna	Gubman	Advisor to Commissioner Carla Peterman	<b>California Public Utilities Commission</b>
Marlon	Flournoy	Assistant Director, Sustainability	<b>Caltrans</b>
Ed	Hardiman	Senior Equipment Engineer	<b>Caltrans</b>
Lauren	Iacobucci	Transportation Planner	<b>Caltrans</b>
Todd	LaCasse	Freight Rail and Logistics Planner	<b>Caltrans</b>
Jeremy	Matsuo	Sustainability - ZEV	<b>Caltrans</b>

Dillon	Miner	Transportation Planner	<b>Caltrans</b>
Thai	Nguyen	Equipment Engineer	<b>Caltrans</b>
Chris	Schmidt	Senior Planner	<b>Caltrans</b>
Patrick	Tyner	Transportation Planner, DRISI	<b>Caltrans</b>
John	Shears	Research Coordinator	<b>CEERT</b>
Kevin	Hamilton	CEO	<b>Central California Asthma Collaborative</b>
Rory	Moore	Business Development Manager	<b>ChargePoint</b>
Rich	Quattrini	Sr. Director, Business Development	<b>ChargePoint</b>
Dedrick	Roper	Grant Operations and Public Policy Manager	<b>ChargePoint</b>
Colleen	Quinn	VP Government RELATIONS	<b>ChargePoint</b>
Aaron	Schneider	Account Executive	<b>ChargePoint</b>
Micah	Berry	Fuels Advocacy Specialist	<b>Chevron</b>
Matt	Franklin	Engineer	<b>Chevron</b>
Mu	Li	Planning Engineer	<b>Chevron</b>
Erik	Mason	Business Operations Manager	<b>ClipperCreek, Inc</b>
Shrayas	Jatkar	Policy Associate	<b>Coalition for Clean Air</b>
Bill	Magavern	Policy Director	<b>Coalition for Clean Air</b>
Kevin	Myose	Fleet Manager	<b>County of San Joaquin</b>
Glenn	Connor	EVSE Program manager	<b>DGS</b>
Gary	Calderon	Principal Consultant	<b>DNV-GL</b>
Adenike	Adeyeye	Research & Policy Analyst	<b>Earthjustice</b>
Paul	Cort	Attorney	<b>Earthjustice</b>
Kent	Williams	Board Advisor	<b>Efficient Drive Trains</b>
Dave	Johnston	Air Pollution Control Officer	<b>El Dorado County AQMD</b>
Alicia	Birky	Analysis Team Lead	<b>Energetics Inc</b>
Katherine	Tartaglia	Associate Consultant	<b>Energetics Inc</b>

David	Greenfader	Business Development	<b>Envision Solar International, Inc., Business Development</b>
Chien	Sze	Engineer	<b>EPA SmartWay</b>
Marcus	Alexander	Manager, Vehicle Systems Analysis	<b>EPRI</b>
John	Kalb	Founder	<b>EV Charging Pros</b>
David	Hughes	VP Government	<b>EV Connect Inc</b>
Alyssa	Werthman	Principal Environmental Engineer	<b>Ford Motor Company</b>
Jamie	Hall	Manager, Advanced Vehicle and Infrastructure Policy	<b>General Motors</b>
Tyson	Eckerle	Deputy Director, ZEV Infrastructure	<b>GOBiz</b>
Matt	Henigan	Deputy Secretary for Sustainability	<b>Government Operations Agency</b>
Shawn	Garvey	CEO	<b>Grant Farm</b>
Thomas	Ashley	Senior Director, Government Affairs & Public Policy	<b>Greenlots</b>
Lin	Khoo	Senior Vice President of Strategy	<b>Greenlots</b>
Lin	Khoo	Senior VP of Strategy	<b>Greenlots</b>
Brandon	Miller	Manager	<b>GSA / Federal</b>
Jeremy	Whaling	Grid Connected Projects Manager	<b>Honda</b>
Jeff	Jetter	Manager / Chief Chemist	<b>Honda R&amp;D Americas, Inc.</b>
Philip	Sheehy	Technical Director	<b>ICF International</b>
John	Smart	Group Lead - Advanced Vehicle	<b>Idaho National Laboratory</b>
Beth	Bourne	Assitant Program Manager	<b>ITS-Davis</b>
Rosa	Dominguez- Faus	researcher	<b>ITS-Davis</b>
Paul	Gruber	STEPS Exec Dir	<b>ITS-Davis</b>
Zhaomiao	Guo	PhD student	<b>ITS-Davis</b>
Raphael	Isaac	Graduate Student Researcher	<b>ITS-Davis</b>
Alan	Jenn	Postdoctoral Researcher	<b>ITS-Davis</b>
Guozhen	Li	Graduate Student	<b>ITS-Davis</b>
Dominique	Meroux	Graduate Student Researcher	<b>ITS-Davis</b>

Mike	Nicholas	Post-doctoral researcher, PH&EV Center	<b>ITS-Davis</b>
Gil	Tal	Professional Researcher	<b>ITS-Davis</b>
Thomas	Turrentine	Director, PH&EV Research Center	<b>ITS-Davis</b>
Xiuli	Zhang	Graduate Student	<b>ITS-Davis</b>
Hengbing	Zhao	Research Engineer	<b>ITS-Davis</b>
Laura	Podolsky	Policy Director	<b>ITS-Davis, NCST</b>
Joel	Pointon	Principal	<b>JRP Charge - Consulting</b>
Scott	Biasco	Manager of Electric Transportation	<b>Los Angeles Department of Water and Power</b>
Michael	Coates	CEO	<b>Mightycomm</b>
Urvi	Nagrani	Director of Marketing & Business Development	<b>Motiv Power Systems</b>
Roland	Hwang	Director, Energy & Transportation Program	<b>NRDC</b>
Kevin	Walkowicz	Sr. Engineer	<b>NREL</b>
Nicole	de Leon	DG Program Manager	<b>NRG EVgo</b>
Claire	Dooley	EV Service Product Manager	<b>NRG EVgo</b>
Taylor	Jones	Advisor	<b>Office of Governor Edmund G. Brown Jr.</b>
Chelsea	Merrill	Director, External Affairs	<b>PECG</b>
Amber	Hassanein	Business Analyst	<b>PG&amp;E</b>
Morgan	Metcalf	Sr Programs Manager	<b>PG&amp;E</b>
David	Sawaya	Principal, Electrification and Alternative Fuels	<b>PG&amp;E</b>
Indea	Snorden	MBA Associate	<b>PG&amp;E</b>
Stacey	Reineccius	CEO	<b>Powertree Services Inc.</b>
F Kent	Leacock	Director Government Relations	<b>Proterra</b>
Seamus	McGrath	Manager - Charging Systems	<b>Proterra</b>
Matthew	Marshall	Executive Director	<b>Redwood Coast Energy Authority</b>
Guy	Hall	President	<b>Sacramento Electric Vehicles</b>

Bill	Boyce	Manager Electric Transportation Research and Development	<b>Sacramento Municipal Utility District</b>
Ralph	Troute	PM Electric Transportation	<b>Sacramento Municipal Utility District</b>
Greg	Haddow	Clean Transportation Program Manager	<b>San Diego Gas &amp; Electric Company</b>
Mike	Schneider	VP and Chief Environmental Officer	<b>San Diego Gas &amp; Electric Company</b>
Rebecca	Levinson	Systems Analyst	<b>Sandia National Labs</b>
Lisa	McGhee	Operations Manager	<b>San Diego Airport Parking Company</b>
Naveen	Berry	Technical Demonstration Manager	<b>SCAQMD</b>
Angie	Boakes	Electric Mobility General Manager	<b>Shell International Petroleum</b>
Matt	Zerega	E Mobility Manager	<b>Shell</b>
Dian	Vazquez	Policy Advocate	<b>Sierra Club California</b>
Dean	Taylor	Principal Advisor, Air and Climate Group	<b>Southern California Edison</b>
Eric	Woychik	Executive Consultant	<b>Strategy Integration, LLC</b>
Chris	Walti	Infrastructure Business Development	<b>Tesla</b>
Robert	Wimmer	Director, Energy and Environmental Research Group	<b>Toyota Motor North America</b>
James	Burns	CSO	<b>TransPower</b>
Joshua	Goldman	VP Business Development	<b>TransPower</b>
Mike	Simon	President & CEO	<b>TransPower</b>
Don	Anair	Senior Engineer, Clean Vehicles Program	<b>Union of Concerned Scientists</b>
David	Greene	Senior Fellow	<b>University of Tennessee</b>
Rachael	Nealer	Engineer	<b>U.S. DOE</b>
Jake	Ward	Program Manager	<b>U.S. DOE</b>
Susan	Burke	Environmental Scientist	<b>U.S. EPA</b>
Trina	Martynowicz	EV & Renewable Energy Coordinator	<b>U.S. EPA</b>
Britney	McCoy	Engineer	<b>U.S. EPA</b>
Aaron	Sobel	Environmental Scientist	<b>U.S. EPA</b>
Miguel	Jaller	Assistant Professor	<b>UC Davis</b>
Marshall	Miller	Senior Development Engineer	<b>UC Davis</b>



Andy	Frank	Professor	<b>UC Davis and Efficient Drive Trains Inc</b>
Jimmy	O'Dea	Vehicles Analyst	<b>Union of Concerned Scientists</b>
Jonathan	Levy	Director of Policy and Strategy	<b>Vision Ridge Partners</b>
Catherine	Williams	Managing Member	<b>Vista Asset Management</b>
Vincent	Wiraatmadja	Associate Attorney	<b>Weideman Group, Inc</b>