

Lawrence Berkeley National Laboratory

Recent Work

Title

THE HIGH-DUTY-FACTOR CONVERSION OF THE BERKELEY HILAC

Permalink

<https://escholarship.org/uc/item/9zv389vk>

Author

Smith, Bob H.

Publication Date

1966-09-19

UCRL-17411

University of California

Ernest O. Lawrence
Radiation Laboratory

THE HIGH-DUTY FACTOR CONVERSION OF THE BERKELEY HILAC

TWO-WEEK LOAN COPY

*This is a Library Circulating Copy
which may be borrowed for two weeks.
For a personal retention copy, call
Tech. Info. Division, Ext. 5545*

Berkeley, California

DISCLAIMER

This document was prepared as an account of work sponsored by the United States Government. While this document is believed to contain correct information, neither the United States Government nor any agency thereof, nor the Regents of the University of California, nor any of their employees, makes any warranty, express or implied, or assumes any legal responsibility for the accuracy, completeness, or usefulness of any information, apparatus, product, or process disclosed, or represents that its use would not infringe privately owned rights. Reference herein to any specific commercial product, process, or service by its trade name, trademark, manufacturer, or otherwise, does not necessarily constitute or imply its endorsement, recommendation, or favoring by the United States Government or any agency thereof, or the Regents of the University of California. The views and opinions of authors expressed herein do not necessarily state or reflect those of the United States Government or any agency thereof or the Regents of the University of California.

Presented at the 1966 Linear Accelerator Conference,
Los Alamos Scientific Laboratory, October 3-7, 1966

UCRL-17111
Preprint

UNIVERSITY OF CALIFORNIA

Lawrence Radiation Laboratory
Berkeley, California

AEC Contract No. W-7405-eng-48

THE HIGH-DUTY-FACTOR CONVERSION OF THE BERKELEY HILAC

Bob H. Smith

September 19, 1966

HIGH-DUTY-FACTOR CONVERSION OF THE BERKELEY HILAC

Bob H. Smith

Lawrence Radiation Laboratory
University of California
Berkeley, California

September 19, 1966

Abstract

A 6-MW dc power supply and a hard-tube modulator system has been installed at the Hilac to supply the anode power for the oscillators of the two linear accelerators. The pulse repetition rate and pulse width are variable. Most bombardments use a repetition rate of 40 pulses per second and pulse widths between 2 and 8 msec.

The rf system and ion-source equipment were modified to handle the increased average power. Additional water cooling was applied to the linac tanks. The coupling line between the two tanks was removed and an electronic phase regulating system was installed. Improved rf amplitude regulators were developed and installed.

Another RCA type-6949 tube was added to the poststripper tank. The rf system now consists of five type-6949 tubes, four of which are self-excited oscillators and one a driven amplifier. The latter serves as a pre-exciter and also keeps the self-excited oscillators on the correct tank mode. The prestripper is excited by an RCA-6949 in a driven amplifier circuit.

Introduction

The availability of a 6-MW, cw-at-28-kV, power supply at Livermore made it economical to replace the Hilac oscillator anode pulse lines with a power supply and hard-tube modulator system. Such a modification was highly desirable because it permitted a very significant increase in the duty cycle of the Hilac -- from 6% to more than 50% at present and perhaps 100% for many beams in the future. Also, it permitted much greater flexibility in a continuously variable pulse width and a variety of repetition rates. In addition it opened the possibility of adding more oscillators and therefore a higher gradient and new beams of heavier ions. Suitable modifications throughout the Hilac had to be made in order to handle the increased average power.

The Anode Power Supply

A one-line diagram of the anode power supply is shown in Fig. 1. It consists of two 3-MW, 14-kV rectifiers connected in series to deliver 28 kV of dc. The Thevenin impedance of this power supply consists of an inductance and resistance in series. This, combined with the resistance and capacitance of the surge network, was designed to form a constant-resistance network, so that the impedance, looking back into the power supply from the point of the crowbar,

is a pure resistance. Thus, when the oscillators draw a rectangular pulse of plate current, the drop in voltage is constant throughout the pulse and the hard-tube modulators do not have to absorb a drop in power-supply voltage during the pulse. They need only provide sufficient voltage drop to absorb the rectifier ripple. By connecting the two rectifier transformers so that one is in a delta-delta configuration and the other a delta-wye configuration, 12-phase ripple is produced, and the peak-to-peak magnitude of the ripple is reduced. This reduces the required voltage drop in the hard-tube modulators.

Initially, the hard-tube modulators served as a high-speed turn-off device in addition, of course, to their modulation function, and the power supply system did not have a crowbar. Unfortunately, we found that the standoff voltage of the series tube in the hard-tube modulator decreased with time until it was not adequate to provide reliable turn-off. The tubes were rated at 80 kV, and when initially installed and spot-knocked, they indeed baked to beyond 80 kV. But in a period of about a week, the standoff voltage gradually diminished to only about 40 kV. With the power supply operating at 28 kV and the presence of high-voltage transients coming back to the power supply from sparking in the linac tanks, the series tubes occasionally sparked over and then did not provide high-speed protection. We cured this problem by adding the ignitron crowbar shown in Fig. 1. This provided complete protection for the hard-tube modulators, oscillators, and other electronic components so that no more damage has been experienced to this equipment due to sparking transients.

However, the pulse currents throughout the power supply caused by the crowbar and rectifier arc-backs were too high to provide adequate insulation life in the main power transformers and step regulator. After a period of about a year, the insulation was damaged in the step regulator and rectifier transformers, and these units broke down. When subjected to high-current pulses of sufficiently short duration that heating is not a factor, transformer insulation life is measured in terms of the number of pulses and varies inversely as the fifth power of the magnitude of the peak pulse current. Thus transformer life is a very sensitive function of the size of high-current pulses. In order to provide adequate transformer life, the 2.5- Ω line reactors shown in Fig. 1 were added to the 12-kV input line.

The fault detector senses over-current in any of the hard-tube modulators, and in the event of a fault, sends a signal to the crowbar firing chassis. This chassis fires the crowbar and sends a turn-off signal to the ignitors in the rectifiers. Also, the fault detector sends a firing signal to the rf crowbars in each of the linac tanks, so that when the rf power is suddenly interrupted, the energy in the tank is dissipated in the tank rather than as a spark in the oscillators.

The hard-tube modulators are connected in a voltage-regulator circuit. The output voltage is compared with a reference; the difference is amplified and drives the grid of the hard-tube modulator.

The reference input of each of the hard-tube modulators on the poststripper are connected in parallel and driven by the poststripper anode reference pulse. The prestripper has its own anode reference pulse. The timing and duration of each of the two reference pulses is slightly different in order to compensate for the difference in rise time of the two linac tanks. Each reference pulse is generated by a univibrator followed by a transistor modulator. This modulator is used as part of an rf regulator. This feedback loop regulates the oscillator anode voltage from the tank rf.

The master pulser is triggered from the 60-cycle power line. The triggering is phased with respect to the 60-cycle line, so that the plate-current pulses occur at a favorable time in the cycle for the ignitron rectifiers. Also, only those repetition rates are used that are suitably related to 60 cycles in such a way that essentially equal heating occurs within the power transformers. A large number of discrete repetition rates meet this requirement, but the only ones provided at present are 8, 24, and 40 pulses per second.

The Hilac rf System

A one-line diagram of the Hilac rf system is shown in Fig. 2. The ion source is located in the high-voltage terminal, which is charged to voltages between 0 and 600 kV by a Cockcroft-Walton rectifier. Ions are accelerated by the potential between the high-voltage terminal and ground and passed through the buncher, which groups the particles for injection into the prestripper linac. The latter raises the energy to 1 MeV per nucleon, and the ions pass through a beryllium stripping foil, which changes their charge-to-mass ratio to 0.3. These ions are injected into the poststripper linac and accelerated to 10 MeV per nucleon. They are then delivered by a beam-transport system to the appropriate cave for use by the experimenter.

The poststripper linac is excited by five 6949 tubes, one of which operates as a driven amplifier and the other four as tuned-plate, tuned-grid self-excited oscillators. In addition to delivering an equal amount of power with the

self-excited oscillators, the driven amplifier provides the high-speed buildup necessary to break through multipactoring and establishes the proper rf mode in the poststripper linac tank.

At the beginning of the rf pulse, when there is no rf in the tank, there is no drive on the self-excited oscillators; during this period only the driven amplifier has rf drive. Thus, it establishes the rf in the tank and establishes the proper rf mode. As the rf builds up in the tank the grid drive on the self-excited oscillators builds up, and since the rf has already been established at the proper frequency in the proper mode, the self-excited oscillators are automatically locked to this mode and frequency.

Before the conversion all 6949's were driven. Our experience with the new system indicates that it is much easier to live with on a day-to-day basis than the previous all-driven system. There are, of course, many fewer components to maintain, but more important than this, is the simplification it provides in tuning. There is no neutralization to get out of adjustment and there is not a long line of amplifiers, each of which have to be tuned to maximum in order to have adequate grid drive. There is only one grid tuning adjustment per tube and this is adjusted to provide as much grid drive as is desired. There is essentially infinite grid drive available from the tank just by turning the knob.

The frequency regulator of the system simply tunes the master oscillator until its frequency matches the resonant frequency of the poststripper tank. The prestripper tank then is tuned to this frequency by motor-driven tuning loops. A phase detector receiving its signal from the two linac tanks provides phasing of the rf drive to each of the tanks to make them correct for accelerating particles. A coarse tuning loop receiving its signal from the phase detector adjusts the motor-driven tuning loops of the prestripper linac to make the phase approximately correct. An electronic signal from the phase detector provides high-speed phase control of the two drive systems by means of an electronic phase shifter. Thus, the phase between the rf in the two linac tanks during the top of the rf pulse is regulated to about 1 deg.

Present Duty-Factor Limitations

To handle the increased average power put into the Hilac, water cooling of all parts of the poststripper and the prestripper tanks has been increased. A jacket was put around both tanks and water circulated over them. The ion-source equipment was redesigned to handle the higher power requirements also. The maximum pulse width that the Hilac now operates at is shown as a function of tank gradient in Fig. 3. Maximum operating beam currents of a number of typical ions are shown in Table I.

At present the pulse width, and therefore the average beam current, is limited by over-

heating at the high-energy end of the poststripper tank, by anode dissipation in the hard-tube modulators, and by the average power capability of the rf oscillators. The first limitation can be reduced by increasing the rate of flow of water at the high-energy end of the poststripper tank. The next limitation can be reduced by adding an extra series tube in each of the hard-tube modulators. Space was provided in the modulators to do this. The third limitation can be reduced by adding a sixth tube to the poststripper tank. We added a sixth vacuum insulator and anode coupling loop during the conversion, so that the sixth tube could be added easily. Also, we built a spare hard-tube modulator (Fig. 1) for this purpose.

Conclusion

Our experience with high-duty-factor operation of the Hilac indicates that the most serious problem is that of providing adequate cooling. Control and maintenance of the rf phase between linac tanks did not prove to be difficult. For high-duty-factor linacs requiring a number of tubes to supply the rf power, I strongly recommend a combination of driven and self-excited oscillators. Three or four self-excited oscillators per driven amplifier seems to be about the right ratio.

In a new installation, solid-state rectifiers should be used. Electronic turn-off could be provided by a silicon-controlled-rectifier or magnetic-amplifier. A crowbar is essential. It is necessary to limit the current surges in the rectifier transformers, caused by the crowbar, to about 4.5 times normal. The technique of designing the surge network to form a constant resistance network with the power-supply impedance works well. I don't think that a modulator must be provided for each oscillator. It probably would be simpler and more reliable to supply all oscillators on a given linac tank from a single modulator.

Acknowledgment

This work was done under the auspices of the U. S. Atomic Energy Commission.

FIGURE LEGENDS

- Fig. 1. The 6-MW anode power supply and hard-tube modulator system.
- Fig. 2. The Hilac rf system. The poststripper linac is driven by one driven amplifier and four TPTG self-excited oscillators. The driven amplifier drives through multipactoring and establishes the correct tank mode. All five tubes share equally during the flat top of the pulse in delivering power to the tank. The rf phase between the two linac tanks is regulated electronically during the flat top of the pulse.
- Fig. 3. Present maximum rf pulse length vs tank gradient at 40 pps. The duty factor is limited by the linac tank cooling.

Table I. Time-average beam currents for 6-msec (15% duty factor) pulse length at 40 pps. The average beam current is proportional to pulse length, but is limited in some cases by ion-source dissipation.

Ion	Charge state	Maximum pulse length (msec)	Average beam current (μA)
D ²	+1	19	50
He ³	+2	19	5
He ⁴	+2	15	50
Li ⁷	+3	13	0.2
B ¹¹	+5	12	15
C ¹²	+5	14	25
N ¹⁴	+6	13	10
O ¹⁶	+6	11	10
F ¹⁹	+6	7	3
Ne ²⁰	+8	8	3
Ar ⁴⁰	+13	8	0.2

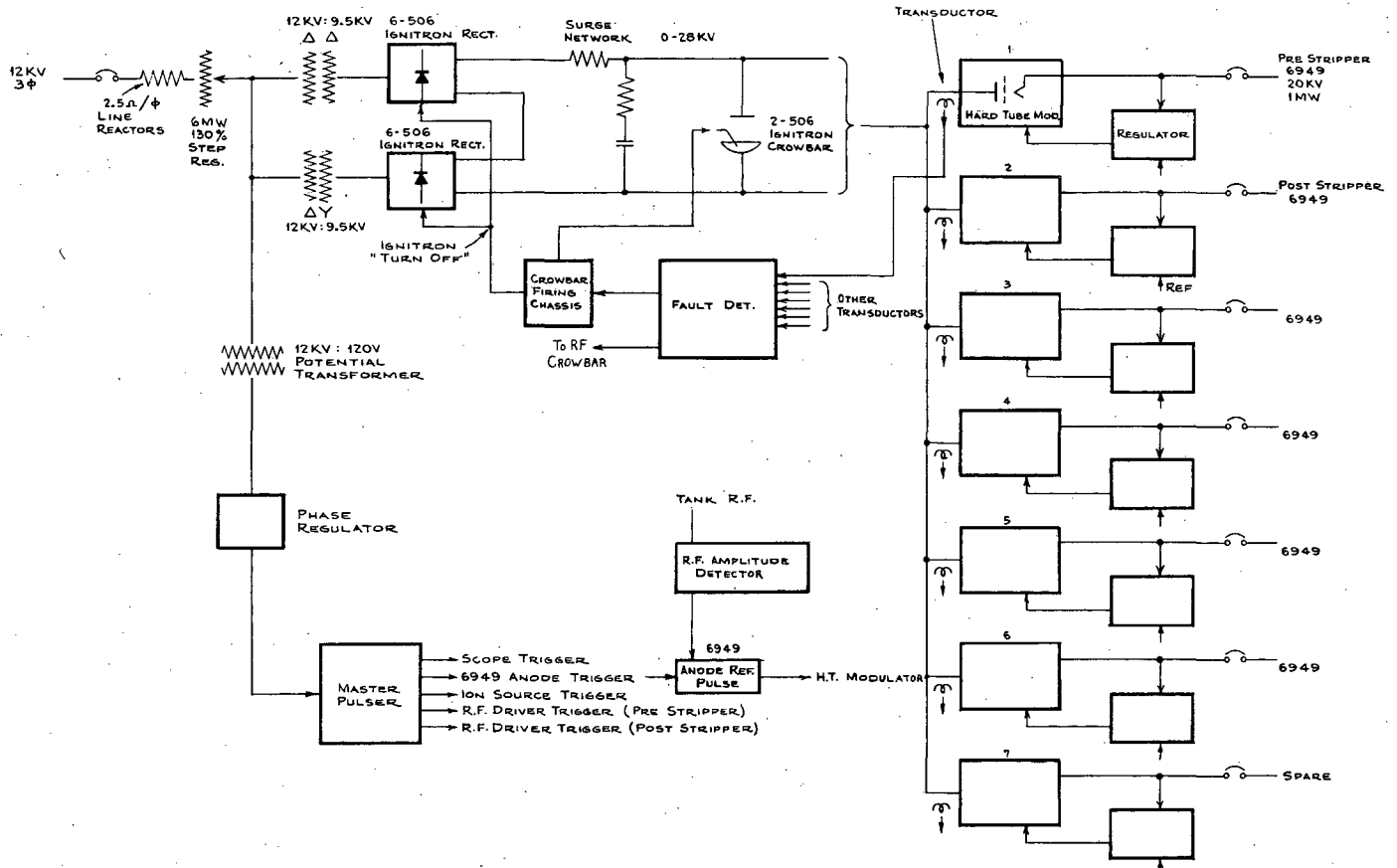

BERKELEY HILAC OSCILLATOR ANODE
POWER SUPPLY

MUB-12547

Fig. 1

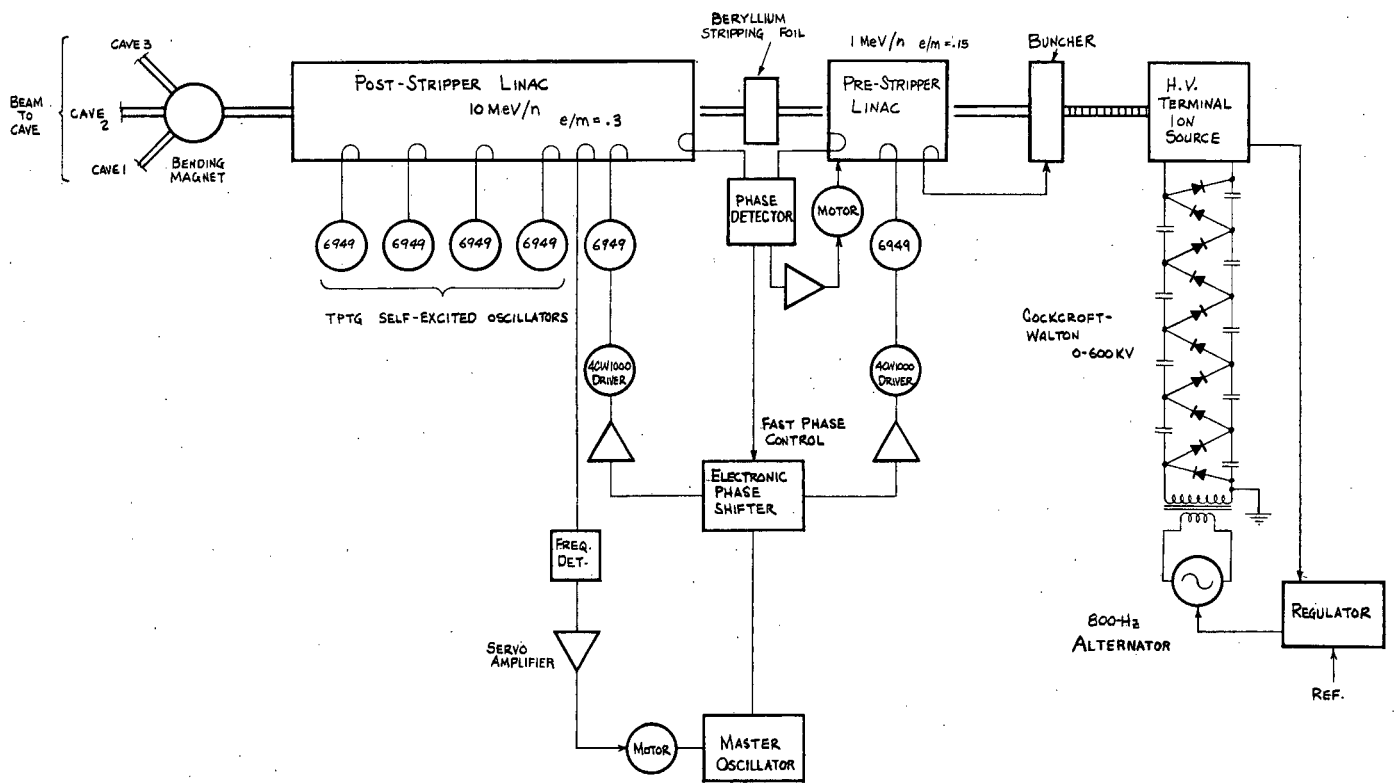

BERKELEY HILAC R.F. SYSTEM

MUB-12648

Fig. 2

HILAC - RF GRADIENT VS PULSE LENGTH¹

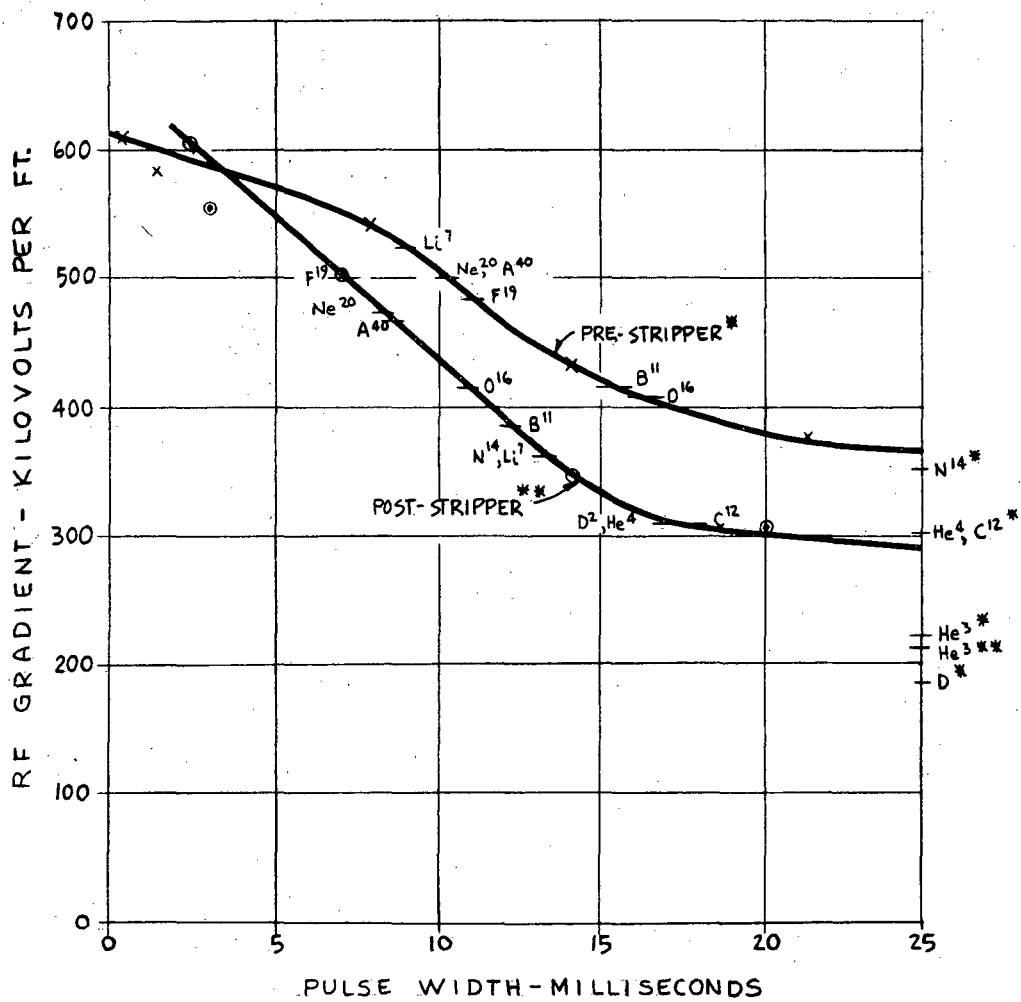

¹ REP. RATE = 40 pps

MUB-12701

Fig. 3

This report was prepared as an account of Government sponsored work. Neither the United States, nor the Commission, nor any person acting on behalf of the Commission:

- A. Makes any warranty or representation, expressed or implied, with respect to the accuracy, completeness, or usefulness of the information contained in this report, or that the use of any information, apparatus, method, or process disclosed in this report may not infringe privately owned rights; or
- B. Assumes any liabilities with respect to the use of, or for damages resulting from the use of any information, apparatus, method, or process disclosed in this report.

As used in the above, "person acting on behalf of the Commission" includes any employee or contractor of the Commission, or employee of such contractor, to the extent that such employee or contractor of the Commission, or employee of such contractor prepares, disseminates, or provides access to, any information pursuant to his employment or contract with the Commission, or his employment with such contractor.

