

Lawrence Berkeley National Laboratory

Lawrence Berkeley National Laboratory

Title

Using measured equipment load profiles to "right-size" HVAC systems and reduce energy use in laboratory buildings (Pt. 2)

Permalink

<https://escholarship.org/uc/item/05k1s6j7>

Authors

Mathew, Paul
Greenberg, Steve
Frenze, David
et al.

Publication Date

2008-06-02

Peer reviewed

Using measured equipment load profiles to “right-size” HVAC systems and reduce energy use in laboratory buildings

Paul Mathew, Ph.D., Lawrence Berkeley National Laboratory

Steve Greenberg, P.E., Lawrence Berkeley National Laboratory

David Frenze, P.E., Earl Walls Associates

Michael Morehead, P.E., Flack+Kurtz, Inc.

Dale Sartor, P.E., Lawrence Berkeley National Laboratory

William Starr, Jr., University of California, Davis

Abstract

There is a general paucity of measured equipment load data for laboratories and other complex buildings and designers often use estimates based on “nameplate” rated data or design assumptions from prior projects. Consequently, peak equipment loads are frequently overestimated, and load variation across laboratory spaces within a building is typically underestimated. This results in two design flaws. Firstly, the overestimation of peak equipment loads results in over-sized HVAC systems, increasing initial construction costs as well as energy use due to inefficiencies at low part-load operation. Secondly, HVAC systems that are designed without accurately accounting for equipment load variation across zones can significantly increase simultaneous heating and cooling, particularly for systems that use zone reheat for temperature control. Thus, when designing a laboratory HVAC system, the use of measured equipment load data from a comparable laboratory will support right-sizing HVAC systems and optimizing their configuration to minimize simultaneous heating and cooling, saving initial construction costs as well as life-cycle energy costs.

In this paper, we present data from recent studies to support the above thesis. We first present measured equipment load data from two sources: time-series measurements in several laboratory modules in a university research laboratory building; and peak load data for several facilities recorded in a national energy benchmarking database. We then contrast this measured data with estimated values that are typically used for sizing the HVAC systems in these facilities, highlighting the over-sizing problem. Next, we examine the load variation in the time series measurements and analyze the impact of this variation on energy use, via parametric energy simulations. We then briefly discuss HVAC design solutions that minimize simultaneous heating and cooling energy use.

1 Introduction

Laboratory facilities present a significant opportunity and a unique challenge for energy efficient and sustainable design, with their inherent complexity of systems, health and safety requirements, long-term flexibility and adaptability needs, energy use intensity, and environmental impacts. The CBECS database indicates that laboratories are among the three most energy intensive building types [EIA 1999]. A single fume hood in a laboratory can consume as much energy as three average U.S. homes. Laboratories often require a minimum of 6 to 12 air changes per hour of outside air. In many areas of the U.S with evolving economies, the high tech industry is an important area of economic growth, making it one of the fastest growing energy-use sectors. However, laboratory facilities have historically been overlooked by the efficiency community, which tended to focus on larger segments of the energy pie, such as offices and retail facilities. Also, laboratories were seen as too specialized and complex to deal with. Energy efficiency has typically been limited to lighting and minor HVAC measures, leaving out the more energy intensive opportunities.

Recent experience has shown that there are significant energy efficiency opportunities in laboratory buildings [Wirdzek et al. 2004]. Some of these measures are common to commercial buildings in general, with no special considerations for laboratories (e.g. variable speed drives, efficient lighting, etc.). Others opportunities require special considerations for laboratories (e.g. energy recovery). Finally, some opportunities are very specific to laboratories (e.g. high-performance fume hoods). The applicability and potential for each of these opportunities will vary based on the type and location of the laboratory.

This paper focuses the use of measured equipment load data to “right-size” and minimize simultaneous heating and cooling energy use in laboratory HVAC systems. “Equipment load” in the context refers to the heat gain due to equipment such as autoclaves, glass washers, refrigerators, computers, etc. There is a general paucity of measured equipment load data for laboratories and other complex buildings and designers often use estimates based on “nameplate” rated data or design assumptions from prior projects. Consequently, equipment loads are frequently overestimated, and load variation across laboratory modules within a building is typically underestimated. This results in two design flaws:

- Oversizing: Overestimation of equipment loads results in over-sized HVAC systems, increasing initial construction costs as well as energy use due to inefficiencies at low part-load operation.
- Simultaneous heating and cooling: HVAC systems that are designed without accurately accounting for equipment load variation across zones can significantly increase reheat energy use, particularly for systems that use zone reheat for temperature control.

Thus, when designing a laboratory HVAC system, the use of measured equipment load data from a comparable laboratory will support right-sizing HVAC systems and optimizing their configuration to minimize simultaneous heating and cooling, saving initial construction costs as well as life-cycle energy costs.

Section 2 addresses the right-sizing issue, by contrasting measured equipment load data with design values that were used for sizing the HVAC systems in several laboratories. Section 3 addresses the second issue i.e. simultaneous heating and cooling, by examining the load variation in time series measurements and analyzing its impact on energy use. This section also briefly discusses HVAC design solutions that minimize simultaneous heating and cooling. Finally, section 4 provides some conclusions.

2 Rightsizing

2.1 Peak Load Estimation

HVAC systems are sized based on a peak condition that takes into account climate-related loads and internal loads from occupants, lighting and equipment. For some of these parameters, there are well-established criteria for peak conditions (e.g. design days for climate), while in others, the designer has to use context specific information (e.g. load diversity) and engineering judgment to determine a peak load. This is especially the case with equipment loads, in which there is uncertainty about several factors:

- Quantity and type of equipment: While this is analyzed and documented by laboratory planners during the programming phase of design, the actual number and type of equipment installed will vary over the lifecycle of the laboratory.
- Rated vs. actual power. For most equipment, the rated (“nameplate”) power is much higher than the actual power, even when the equipment is in full operating mode.
- Schedule of use: Even if the designer has good estimates of above two parameters, the schedule of use is very difficult to derive deterministically, because it is largely driven by user behavior, and the complete inventory of installed equipment is typically not used simultaneously.

The ASHRAE Handbook on HVAC Applications recommends that the designer “should evaluate equipment nameplate ratings, applicable use and usage factors, and overall diversity.” [ASHRAE 1999, pp. 13.2]. However, due to the lack of data on these parameters, it is often difficult to analytically derive the equipment loads.¹ As a result, designers will typically assume the worst case for each of these parameters, which in turn grossly overestimate actual equipment loads [Wilkins 1998, Wilkins and Hosni 2000 cited in Brown 2002]. Furthermore, designers will assume that the worst-case equipment load will be simultaneous with the worst-case climate loads. Conventional engineering methods chronically over-size HVAC systems. Brown [2002] cites several examples, including one in which the size of the cooling plant was halved, with the as-installed plant still having twice the capacity to meet the actual loads of the fully occupied building. An analysis of 26 laboratory projects by Martin [2004] showed that the over-sizing of cooling systems in these projects ranged from 40% to 300% with an average of about 80%.

Data from the Labs21 benchmarking database provides some further insight into this [Mathew et al. 2004]. The database contains energy use and demand data for about 70 laboratory facilities. Figure 1 shows the total electrical demand for the facilities for which measured peak demand data was available. The facilities include various types of laboratories in several different climate zones. The data show that none of the facilities have *total* peak electrical loads more than 15 W/gsf. Note that this metric includes *all* electric end uses i.e. HVAC, lighting, and equipment. Yet, it is common for designers to assume equipment loads *alone* at 10-12 W/sf or more. While this assumption may be appropriate for a few high-intensity lab spaces in a building, it would be unreasonable to assume such high loads building-wide.

¹ ASHRAE indicates that heat gains in laboratories range from 5 W/sf to 25 W/sf, but there are no additional data that would narrow this range for use in the design of a specific laboratory.

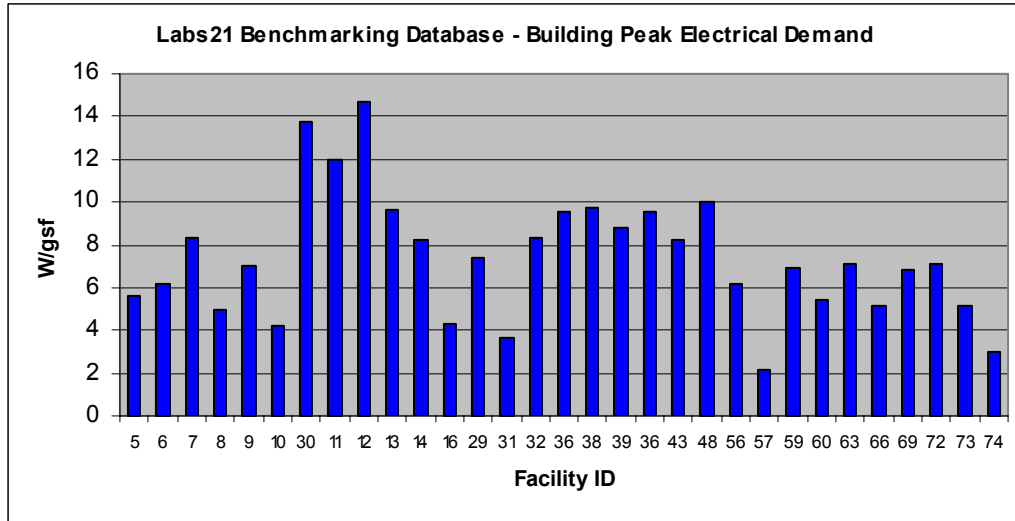

Figure 1. Total electrical demand (W/gsf) for various laboratory facilities recorded in the Labs21 energy benchmarking database.

2.2 Case Study: Measured vs. Estimated Loads

The University of California (UC) Davis campus initiated a project to measure equipment loads at two of its laboratory buildings in order to use the measured data as a basis for sizing the HVAC systems in the design of new comparable facilities. In each building, measurements were made for several laboratory spaces, representing a range of different uses within that building. Clamp-on meters were used to take continuous measurements of equipment electrical loads for each lab space. Each measurement period was typically about 2 weeks long. The measurements were taken when the labs were nominally fully occupied and used. Three quantities were measured:

- Apparent instantaneous power: The product of the voltage and the current at any given instant.
- Actual instantaneous power: This is the actual instantaneous power draw – which becomes a thermal load to the space.
- Average interval power: This is obtained by averaging the actual instantaneous power over each 15-minute interval (this quantity is typically measured by utility interval meters to determine demand charges).

Figure 2 shows the 15-minute interval measured data for two laboratory spaces, each of which was measured for about 4 weeks. The figure shows the peak apparent instantaneous power, peak actual instantaneous power and the average interval power for each 15-minute interval. As expected, in each interval the peak apparent power is always equal to or higher than the peak actual power, which in turn is always higher than the average interval power. In space A, the overall peak apparent power is about 8 W/sf and the overall peak actual power is about 7.5 W/sf. The maximum interval power is only about 3.75 W/sf, which is less than half the overall peak apparent power. In space B, the overall peak apparent power is about 40 W/sf, the overall peak actual power is about 29 W/sf, while the maximum interval power is about 6 W/sf – which is only 15% of the overall peak apparent power.

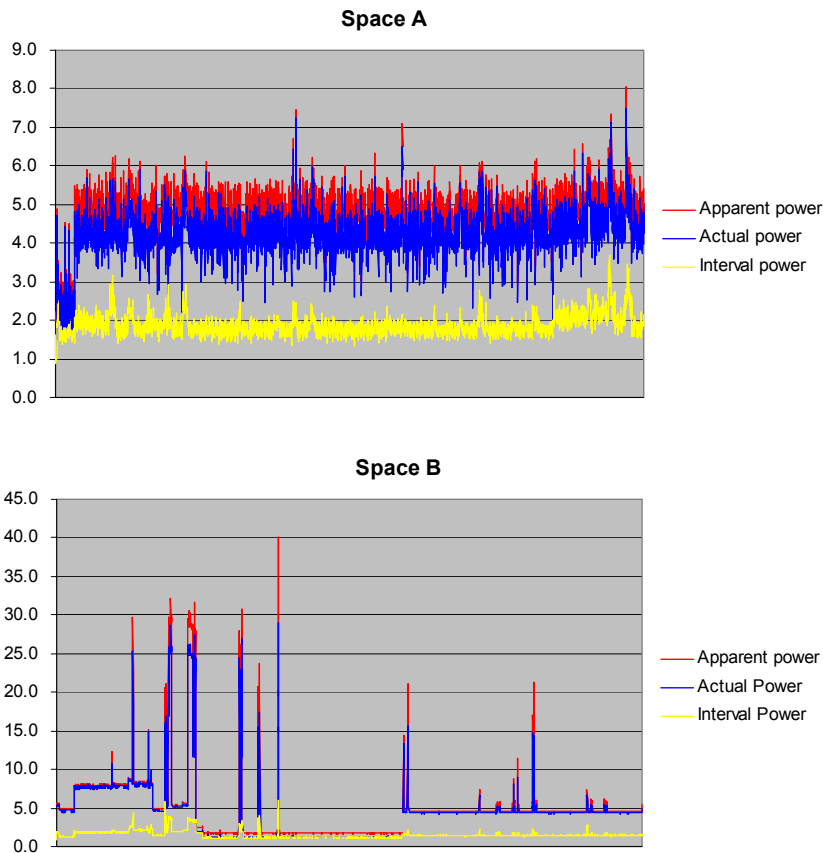

Figure 2. 15-minute interval measurements of equipment loads for two laboratory spaces in the UC Davis building. "Apparent power" is the peak apparent instantaneous power in each interval; "Actual power" is the peak actual instantaneous power in each interval; "Interval power" is the average power in each interval.

Generally, space temperatures are not sensitive to instantaneous peaks of a few seconds, and therefore, it is unnecessary to size HVAC systems to peak instantaneous power. (The only exception to this would be in highly specialized labs with equipment, processes or instrument calibration requirements that require space temperatures to be very tightly controlled.) In most situations, it is more appropriate to size HVAC systems to the maximum interval power. Yet, it is not uncommon for designers to assume equipment loads that even exceed the peak instantaneous power. Figure 3 compares the measured loads to the assumed design loads for several different laboratory spaces in one of the buildings at UC Davis. This shows that the design assumptions were 2 to 5 times the peak instantaneous power, and were a whole order of magnitude above the maximum interval power. Evidence from laboratory designers and planners suggests this is not unusual and occurs widely in laboratory design practice. ²

² It is important to note that the sizing approach for electrical systems is different from HVAC systems. The electrical designer is more constrained by the National Electrical Code, and other code and safety constraints. HVAC designers' have much greater latitude in their approach to sizing. HVAC constraints are largely self-imposed, consisting primarily of the "code of common sense" and the risk of liability.

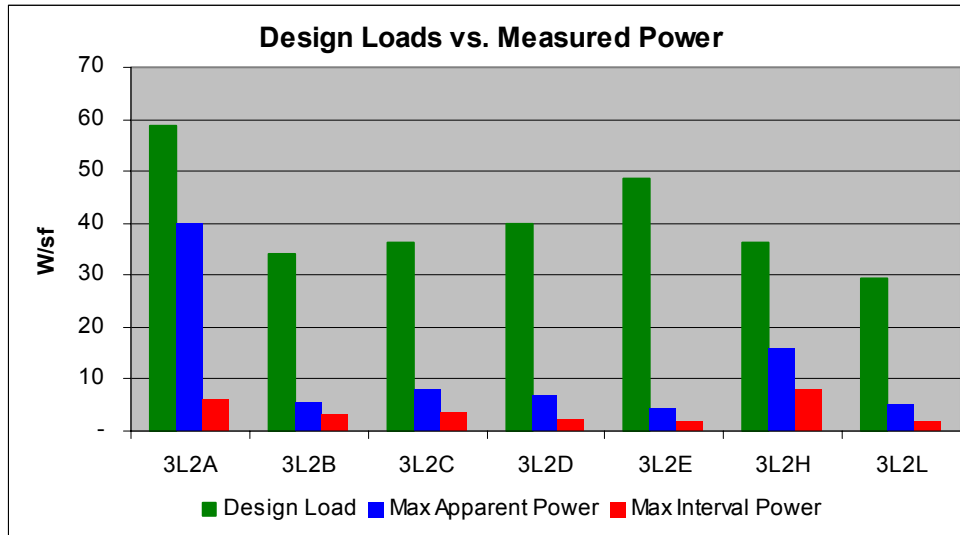

Figure 3 Comparison of equipment power used for design, measured peak apparent (instantaneous) power and maximum interval power for various laboratory spaces in UC Davis.

2.3 Benefits of Right-sizing

A study by Enermodal and NREL [2003] demonstrates the influence of the design assumption for plug loads on the sizing of mechanical equipment. The analysis was conducted on a prototypical 100,000 sf laboratory building, in different climatic zones. The minimum ventilation rate for the building was 1 cfm/sf. The base case equipment load was 12 W/sf, which corresponds to an “over-size” load, and parametric cases were modeled with “right-sized” loads of 8 W/sf and 4 W/sf. Figure 4 illustrates the reduction in total chiller tonnage from rightsizing. For example, in Atlanta the assumption of 8W/sf results in a reduction of 100 tons of cooling, while the assumption of 4 W/sf results in a reduction of about 200 tons. The analysis by Martin [2004] computed the cost of over-sizing HVAC and piped utilities in laboratory projects to be at least \$7.50/sf, and more likely to be 2 or 3 times that, depending on the extent of over-sizing.

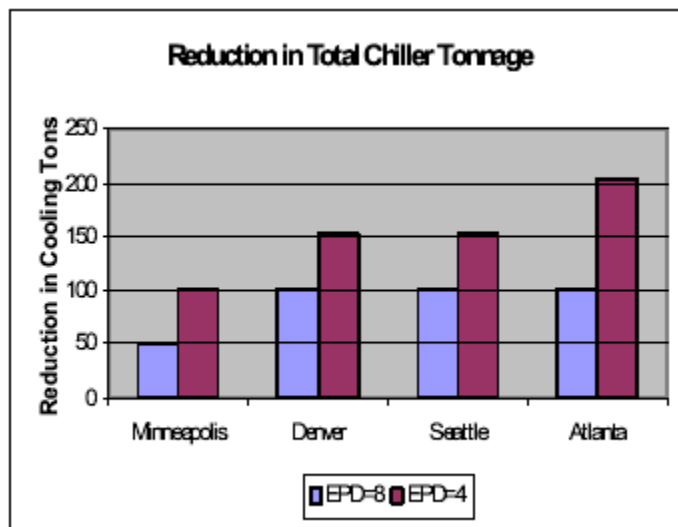

Figure 4. Reduction in chiller tonnage due to rightsizing equipment load down from 12 W/sf, to 8W/sf and 4 W/sf, for different climatic contexts. Based on parametric simulation study of a prototypical 100,000 sf laboratory building [Enermodal and NREL 2003].

Some designers suggest that equipment load is not relevant for rightsizing, because HVAC equipment sizes are driven by ventilation requirements, not equipment loads. While this may be true in some instances (e.g. laboratories with low equipment loads and high minimum ventilation rates), it cannot be generalized. It should also be noted that ventilation requirements themselves are often set at an unnecessarily high level. Some organizations have recently revisited their minimum ventilation requirements and revised them downward. The chiller tonnage analysis above, which assumed 1cfm/sf minimum ventilation requirement, clearly shows that equipment loads affect chiller tonnage in a wide range of climatic conditions. It is recommended that designers at least do a sensitivity analysis during design, to assess the impact of equipment loads on HVAC sizes.

The most common argument against rightsizing is the risk of under-sizing and who carries that risk. As many design engineers have observed, the legal and contractual basis for design services rarely rewards rightsizing, and almost certainly will penalize under-sizing. Right-sizing requires that owners and designers come to agreement on the basis for right-sizing and the associated risk management. This was the case with the design for the central plant of the new University of California campus at Merced. In order to avoid the problem of over-sizing the central plant, the owner took the initiative to right-size the plant based on benchmark data from other campuses [Brown 2002]. Instead of just using design values that assume a worst-case estimate, a “most likely maximum” (MLM) load was also used and the difference between the MLM and the design loads were value-engineered to reach a reasonable margin of safety.

The Labs21 Environmental Performance Criteria [Labs21 2005, Mathew et al. 2002] recommends the following approach for right-sizing HVAC systems based on measured equipment loads:

“...For each comparable laboratory space, obtain one week (7 days) of continuous power metering at a distribution panel level of all laboratory equipment, including plug loads and hard-wired equipment...Metering data should be obtained while the spaces are fully occupied. Continuous metering data should be time averaged over 15 minute time periods. Design heat load criteria for each typical laboratory space in the facility should then be based on the maximum load indicated over the metering period...”

It should be noted that this approach represents a minimum requirement and longer or more detailed measurements may be required for specialized situations.

In addition to using measured loads for right-sizing, probability-based analysis (PBA) can also be used, especially if there are no comparable laboratories available in which to measure loads. A more detailed description of PBA is beyond the scope of this paper, and is provided by Martin [2004]. PBA is essentially a “bottoms-up” approach to derive diversity factors for space loads based on aggregating probability of use for each heat source in the space. The two approaches - PBA and load measurements - can be used in conjunction with each other, providing two reference points for right-sizing.

3 Simultaneous Heating and Cooling

3.1 Measured Load Variation

As noted in the introduction, over-sizing is only one of the problems resulting from incorrect estimation of equipment loads. The other major problem is the under-estimation of load variation across different laboratory spaces, which in turn exacerbates the problem of simultaneous heating and cooling, particularly for systems that use zone reheat for temperature control. Figure 5 shows the range of 15-min interval power for various laboratory spaces in the UC Davis laboratory building referenced earlier. The maximum for most spaces is under 6 W/sf. A few are between 6

and 10 W/sf and one space is high-intensity at about 17 W/sf. This is a fairly common situation, where one or two labs have very high equipment loads compared to the others. The problem arises when all these labs are served by a single air-handling unit with zone reheat coils for temperature control (a widely used HVAC strategy). The high-intensity labs then drive the supply air temperatures and flows to handle their high equipment loads, and as a result, all the other labs have to use reheat to maintain desired temperatures. This issue does not always come up during design, because some designers assume a uniform equipment load intensity for all laboratory spaces served by an air handler and assume no variation between those spaces. Energy simulations conducted during the design phase that reflect this assumption will not show the increased reheat energy use due to load variation.

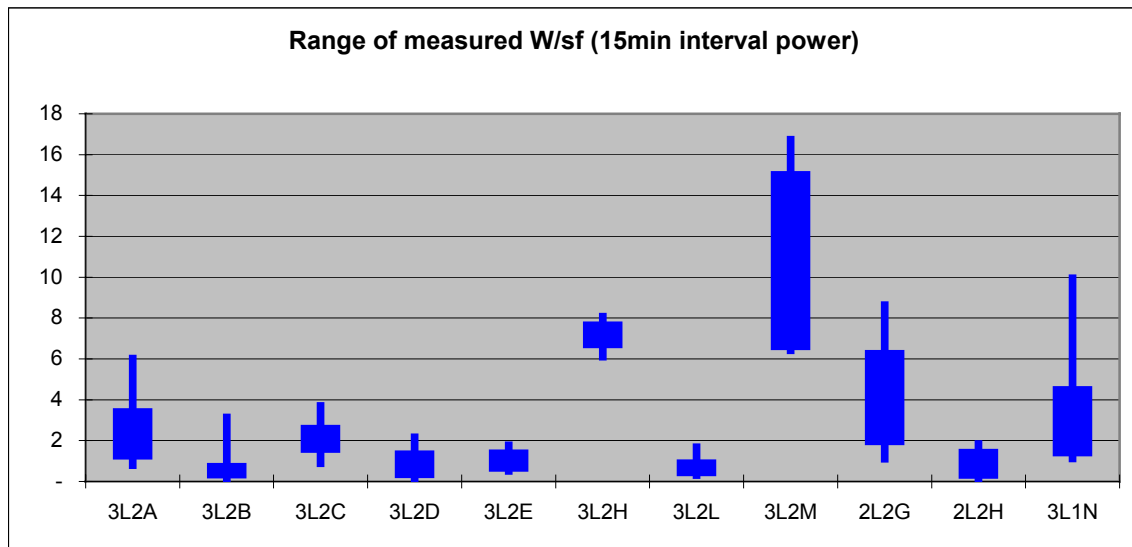

Figure 5. Range of measured 15-min interval power for various laboratory spaces in a building at UC Davis. The upper and lower ends of the lines represent maximum and minimum respectively. The upper and lower ends of the boxes represent 99th and 1st percentiles of the measurements respectively.

3.2 Energy Use Analysis

In order to analyze the increase in reheat energy use arising from equipment load variation, several parametric energy simulations were conducted using the DOE-2.2 energy simulation tool. The simulation model consisted of a set of five laboratory spaces served by a single air-handling unit (figure 6). In order to eliminate envelope-related load variations across these spaces, the boundary conditions of all the spaces were assumed to be adiabatic. The lighting and occupancy load profiles in all the spaces were identical.

Each parametric case consisted of two simulations:

- Simulation with load variation (“Var”): One zone has a “high-intensity” equipment load profile, while the remaining zones have a “typical” load profile.
- Simulation with uniform loads (“Uni”): All zones have the same uniform equipment load profile, which represents an area-weighted average of the “high-intensity” and “typical” load profiles.

These profiles are indicated in figure 7. The total building equipment load in any given hour is identical for both simulations, as are all other parameters. Thus, energy impacts of load variation can be isolated and analyzed.

| |
|---|
| Z O N E 1 <i>Typical load</i> |
| Z O N E 2 <i>Typical load</i> |
| Z O N E 3 <i>High-intensity load</i> |
| Z O N E 4 <i>Typical load</i> |
| Z O N E 5 <i>Typical load</i> |

Figure 6. Simulation model used to analyze the energy impact of load variation. Boundary conditions for all zones were set to be adiabatic to eliminate envelope-related variations in loads for each zone. Zone 3 is about 12.5% of the total area.

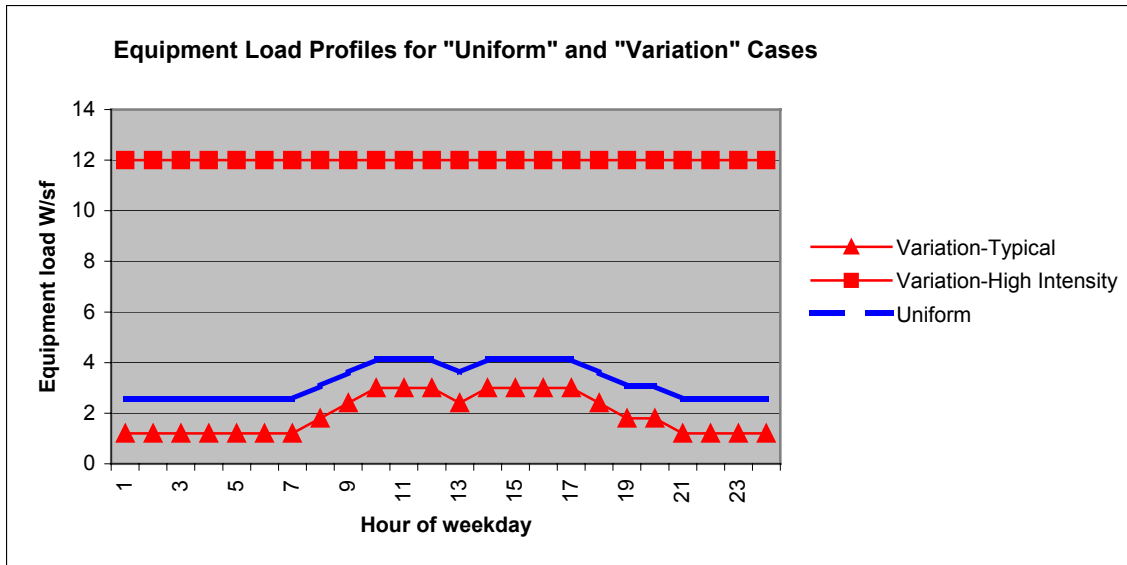

Figure 7. Equipment load profiles used for simulation with load variation and simulation with uniform loads. "Variation-High Intensity" and "Variation-Typical" represent high-intensity and typical space load profiles in the simulation with load variation. "Uniform" represents the area-weighted load profile in all spaces for the simulation with uniform loads. (The total equipment loads for the building in each simulation are identical.)

The basecase model has a VAV system with hot-water reheat, and a water-cooled chiller plant and natural gas boiler. HVAC component and system efficiencies were set to be consistent with good practice. None of the HVAC component and system parameters were varied in the

parametric simulations. The minimum outdoor air ventilation rate for these spaces was set to be 1 cfm/sf.

Figure 8 shows the base case source energy use intensity in three different climates in the U.S. The increase in total source energy intensity due to load variation ranges from 10% in San Francisco, to 14% in Atlanta. An analysis of the simulation results showed that the bulk of this is due to additional heating, as expected. The increase in heating energy use by zone reheat coils was 48% in Washington DC, 50% in San Francisco and 68% in Atlanta.

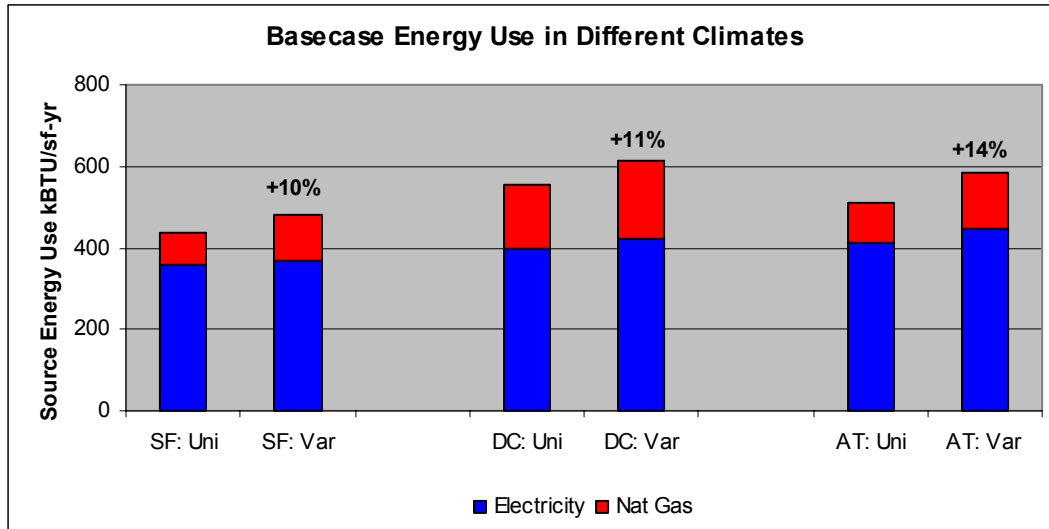

Figure 8. Basecase source energy use intensity in three different U.S. climates. SF: San Francisco, DC: Washington D.C., AT: Atlanta. “Uni”: uniform load simulation, “Var”: simulation with load variation. The percentages are the increase in total source energy relative to the “Uni” for each case.

The increase in reheat energy due to load variation depends on the minimum ventilation rate. Higher ventilation rates will increase the total energy use. However, as ventilation rates increase, the heating and cooling requirements are less “internal load-driven” and more “ventilation-driven”, thereby reducing the impact due to load variation. Figure 9 shows that if the ventilation rate were doubled to 2 cfm/sf, the percentage increase is 7% (vs. 11% for 1 cfm/sf). At 3cfm/sf, the impact of load variation on reheat energy use is minimal.

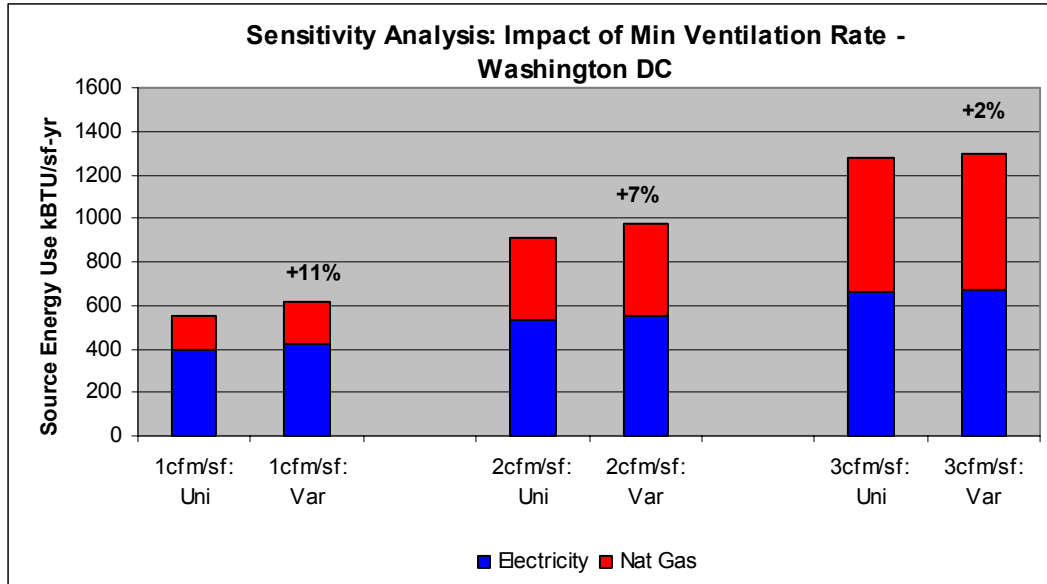

Figure 9. Sensitivity analysis of source energy use intensities for different ventilation rates. All results are for Washington D.C. climate.

Another factor that affects the increase in reheat energy is the extent of the differential between the loads in the high-intensity space and the other spaces. In the base case, the high intensity load was 12 W/sf, while the peak of the typical load profile was about 3 W/sf. If the differential is reduced, the amount of increase in reheat energy use will correspondingly reduce. In order to explore this effect, a parametric analysis was done with the high-intensity load halved to 6 W/sf. The results for two different climates are shown in figure 10. In San Francisco, the increase drops from 10% to 7%, while in Washington DC it drops from 11% to 6%.

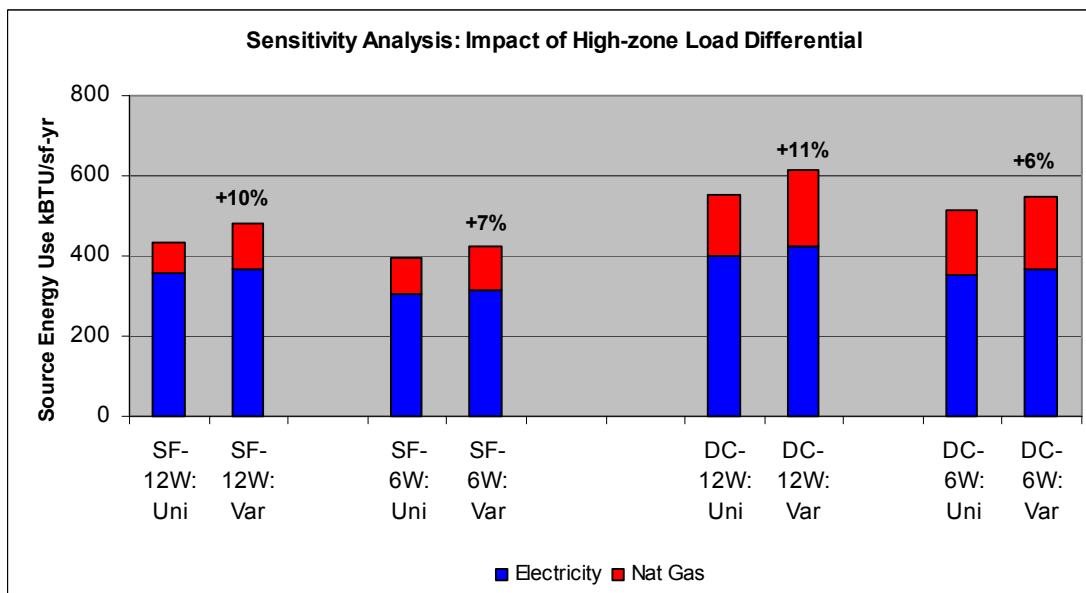

Figure 10. Sensitivity analysis of degree of load differential between high-intensity and typical zone. 12W: refers to base case of 12 W/sf in high-intensity zone. 6W refers to alternative with 6W/sf in high-intensity zone. SF: San Francisco, DC: Washington DC.

Note that in all the above cases, the simulation models assume that the HVAC controls are working properly as intended. However, experience from re-commissioning laboratories indicates that HVAC controls often deviate from design intent, and consequently the energy use due to simultaneous heating and cooling can increase dramatically.

3.3 Strategies to Minimize Reheat Energy Use

As the above simulation analysis showed, equipment load variation in laboratories can increase energy use in laboratories that have systems with reheat. The magnitude of this increase varies with location, ventilation rate, and degree of load variation.

The first step in minimizing reheat energy use is to properly assess it during the design process. It is often the case that HVAC designers assume uniform loads across the labs and do not account for the variation that inevitably occurs. Energy simulations used during design should model the reheat energy use caused by load variation. The Labs21 Modeling Guidelines [Labs21 2004], which are designed to be used in conjunction with the ASHRAE 90.1 standard [ASHRAE 2001], specify a standardized approach to incorporate load variation into the simulation models used for compliance and benchmarking.

There are several different HVAC system alternatives that can mitigate the reheat energy use, as shown in figure 11 [Morehead 2003]. They all involve separating the thermal and ventilation systems. While a more detailed description of these systems is beyond the scope of this paper, they are briefly described below:

- Dual duct with terminal heating (DDTH): This system consists of two separate variable volume supply air streams: one with tempered air, and one with cold air. Labs that require more cooling will draw more air from the cold air stream while others will draw primarily from the tempered air stream.
- Zone cooling and heating coils (ZC): This system has a single tempered supply air stream, with the primary cooling and heating provided by zone heating and cooling coils.
- Ventilation air with local fan coils (FC): This is similar in principle to the zone cooling and heating coils. The difference is that the heating and cooling occurs with fan coil units rather than coils directly in the ventilation air stream.
- Ventilation air with radiant cooling (RC): This system also has a tempered supply air stream for ventilation. Space cooling is provided by radiant panels or chilled beams. Space heating is provided by zone heating coils located in the supply air stream.

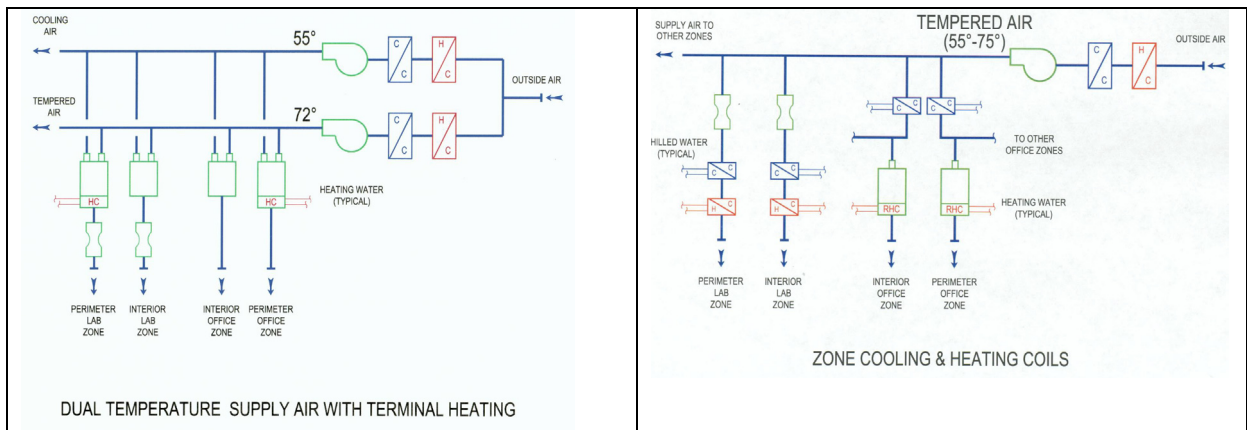

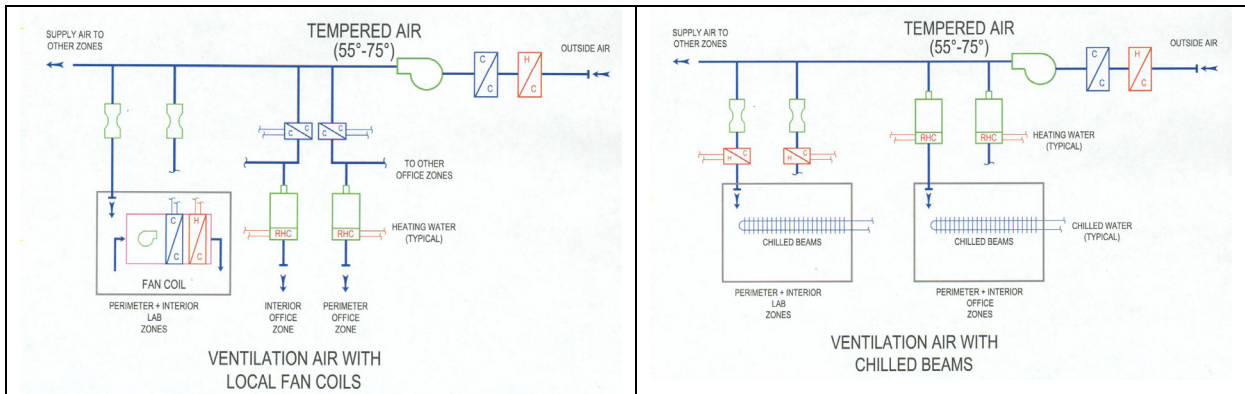

Figure 11. Alternative HVAC systems to minimize reheat energy use caused by load variation between zones.

These systems may have a higher construction cost than the conventional VAV system with reheat. They may also have higher and more decentralized maintenance requirements. However, the energy savings may result in lower overall life cycle cost, depending on the cost of energy as well as other contextual factors. Integrated design can minimize construction cost premiums. Morehead [2003] documents a case study of a 90,000 sf laboratory in which the incremental cost for a DDTH system was only about \$16,400, which amounts to about \$0.18/sf. ZC, FC, and RC systems require less space for ducts in load-driven labs, since the ducts are only for ventilation air, not thermal conditioning. These systems also provide more flexibility in adding cooling capacity to the space.

Finally, it is important to note that good operations and maintenance practices can help to minimize energy use in all the system types described above. Continuous commissioning and diagnostics can help to identify zones with excessive reheat, and adjust system control and operation accordingly.

4 Conclusion

Equipment load measurements from various laboratories showed that peak equipment loads are significantly overestimated. Furthermore, the data showed significant load variation between spaces. A simulation analysis demonstrated that this can result in excessive energy use due to simultaneous heating and cooling in VAV reheat systems.

When designing a laboratory HVAC system, the use of measured equipment load data from a comparable laboratory can effectively support right-sizing HVAC systems and optimizing their configuration to minimize simultaneous heating and cooling, saving initial construction costs as well as life-cycle energy costs. The minor cost of measuring a comparable laboratory is far outweighed by the potential benefits of using the data to reduce HVAC system sizes and energy use. Additionally, it is important to accurately account for load variation in energy simulations conducted during design, in order to better evaluate the energy efficiency of alternative HVAC systems vis-à-vis simultaneous heating and cooling.

Although this paper focused on laboratory buildings, the lessons may apply to other complex building types such as data centers, cleanrooms and hospitals, in which equipment loads are high, variable, and for which there is a lack of available measured data.

5 Acknowledgements

The work described in this paper was funded in part by the Laboratories for the 21st Century (Labs21) Program, a joint program of the U.S. Environmental Protection Agency and the U.S. Department of Energy's Federal Energy Management Program (www.labs21century.gov).

6 References

- ASHRAE [2001]. ASHRAE/IESNA Standard 90.1-2001. Energy Standard for Buildings Except Low-Rise Residential Buildings. American Society of Heating, Refrigerating and Air-conditioning Engineers. Atlanta, Georgia.
- ASHRAE [1999]. HVAC Applications Handbook 1999. American Society of Heating, Refrigerating and Air-conditioning Engineers. Atlanta, Georgia.
- Brown, K. [2002]. "Setting Enhanced Performance Targets for a New University Campus: Benchmarks vs. Energy Standards as a Reference?" *Proceedings of the 2002 ACEEE Summer Study of Energy Efficiency in Buildings*. ACEEE, Washington, D.C.
- Energy Information Administration [1999]. Commercial Building Energy Consumption Survey, Energy Information Administration, U.S. Department of Energy. Available on the internet at: www.eia.doe.gov/emeu/cbecs/contents.html
- Enermodal and NREL [2003]. "Laboratories for the 21st Century Energy Analysis" Published on the internet at: http://www.labs21century.gov/toolkit/case_studies.htm
- Labs21 [2005]. "Labs21 Environmental Performance Criteria version 2.1", published on the internet at: <http://www.labs21century.gov/toolkit/epc.htm>
- Labs21 [2004]. "Labs21 Laboratory Modeling Guidelines using ASHRAE 90.1" published on the internet at: http://www.labs21century.gov/toolkit/bp_guide.htm
- Martin, J. [2004]. "Filling a Scientific Void in Laboratory Planning and Design. A Case for Probability Based Analysis." Syska Hennessy Group, San Diego CA.
- Mathew, P., D. Sartor, O. van Geet, S. Reilly. [2004] "Rating energy efficiency and sustainability in laboratories: Results and lessons from the Labs21 program," *Proceedings of the 2004 ACEEE Summer Study of Energy Efficiency in Buildings*. ACEEE, Washington, D.C.
- Mathew, P., D. Sartor, W. Lintner, P. Wirdzek, [2002]. "Labs21 Environmental Performance Criteria: Toward LEED for Labs", *The Austin Papers*, Best of the 2002 International Green Building Conference, Building Green, Brattleboro, VT.
- Morehead, M. [2004] "The problem with Single-Duct VAV: The Built-in Inefficiency of a Common Lab HVAC System," *presented at the Laboratories for the 21st Century Annual Conference*, Oct 2003, St. Louis, Missouri.
- Wilkins, C. K. [1998]. "Electronic Equipment Heat Gains in Buildings". *ASHRAE Transactions*. 1998, V. 104, Pt. 1. Atlanta, Georgia: American Society of Heating, Refrigerating and Air-conditioning Engineers.
- Wilkins, C.K., M.H. Hosni [2000]. "Heat Gain from Office Equipment". *ASHRAE Journal*. 42:6:33-44.
- Wirdzek, P., W. Lintner, P. Mathew, N. Carlisle. [2004] "Energy efficiency programs for niche markets: The Labs21 program as an exemplar," *Proceedings of the 2004 ACEEE Summer Study of Energy Efficiency in Buildings*. ACEEE, Washington, D.C.