

Lawrence Berkeley National Laboratory

Lawrence Berkeley National Laboratory

Title

Progress on the Modeling and Modification of the MICE Superconducting Spectrometer Solenoids

Permalink

<https://escholarship.org/uc/item/57z4z7r8>

Author

Virostek, S.P.

Publication Date

2011-06-30

PROGRESS ON THE MODELING AND MODIFICATION OF THE MICE SUPERCONDUCTING SPECTROMETER SOLENOIDS *

S.P. Virostek[#], M.A. Green, T. Niinikoski, S. Prestemon and M.S. Zisman
Lawrence Berkeley National Laboratory, Berkeley CA 94720, USA

Abstract

The Muon Ionization Cooling Experiment (MICE) is an international effort sited at Rutherford Appleton Laboratory (RAL) in the UK, that will demonstrate ionization cooling in a section of realistic cooling channel using a muon beam. The spectrometer solenoids are an identical pair of five-coil superconducting magnets that will provide a 4-tesla uniform field region at each end of the cooling channel. Scintillating fiber trackers within each of the 400-mm diameter magnet bore tubes will measure the emittance of the beam as it enters and exits the cooling channel. Each of the 3-meter long magnets incorporates a three-coil spectrometer magnet section and a two-coil section that matches the solenoid uniform field into the MICE cooling channel. The cold mass, radiation shield and leads are kept cold by means of a series of two-stage cryocoolers and one single-stage cryocooler. Various thermal, electrical and magnetic analyses are being carried out in order to develop design improvements related to magnet cooling and reliability. The key features of the spectrometer solenoid magnets are presented along with some of the details of the analyses.

INTRODUCTION

The cooling channel portion of the Muon Ionization Cooling Experiment (MICE) [1] will consist of three absorber focus-coil (AFC) modules [2], each containing a liquid hydrogen absorber and two superconducting focusing coils, along with two RF and coupling-coil (RFCC) modules [3], each of which contain four 201 MHz normal-conducting accelerating RF cavities centered on a superconducting solenoid. The spectrometer solenoid modules are located at either end of the cooling channel, as shown in Fig. 1.

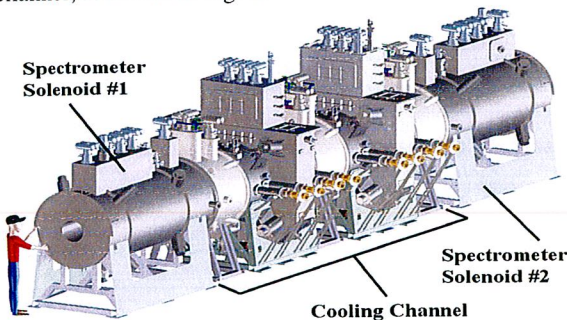

Figure 1: MICE cooling channel 3D CAD image.

Muon ionization cooling is performed by the absorbers to reduce the beam emittance, and the RF cavities re-accelerate the beam. Each spectrometer solenoid consists

of five superconducting coils wound on a common 2923 mm long aluminum mandrel. A photo of the magnet cold mass after coil winding and before the cover was welded on is provided in Fig. 2. Match Coil 1 and Match Coil 2 operate as a focusing doublet to match the beam in the spectrometer solenoid with the beam in the adjacent AFC modules. The spectrometer portion of the module, consisting of End Coil 1, the Center Coil, and End Coil 2 will generate a 4-tesla uniform field ($\Delta B/B < 3 \times 10^{-3}$) over a 1-meter long and 0.3 meter diameter volume. The tracker detector located in the bore of these three coils is made up of five planes of scintillating fibers, which are used to measure the emittance of the muons as they enter and exit the cooling channel. Additional details of the spectrometer solenoid design and operating parameters have been presented in previous papers [4,5].

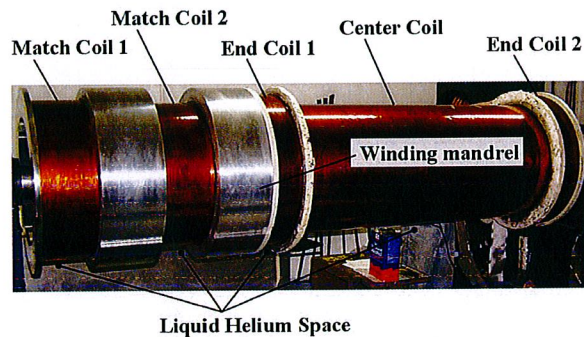

Figure 2: Spectrometer solenoid cold mass assembly.

During the recent testing and training of one of the spectrometer solenoids, several problems arose that resulted in the need to disassemble the magnet and to carry out detailed analyses and a review of the existing design. The primary concerns are the protection of the magnet leads during a quench and excessive heat load on the magnet cold mass. Details of the design issues and the analyses are presented here.

MAGNET TESTING AND TRAINING

The coils were connected in series and run with a single power supply during training. For operation in the MICE experiment, the coils will run independently at currents ranging from 223 to 271 amps. To qualify the magnets, all five coils will be trained to a current of 275 amps. The coils had all reached 238 amps previously (in 2009) when an HTS lead burned out due to inadequate cooling of the lead area. This situation was successfully remedied by adding a dedicated, single-stage cryocooler mounted adjacent to the leads. In the middle of FY2010, the latest version of the spectrometer solenoid was successfully cooled down in preparation for the completion of coil

*This work was supported by the Office of Science, U.S. Department of Energy under DOE contract number DE-AC02-05CH11231.

[#]spvirostek@lbl.gov

training. Figure 3 shows one of the spectrometer solenoid magnets during a training quench.

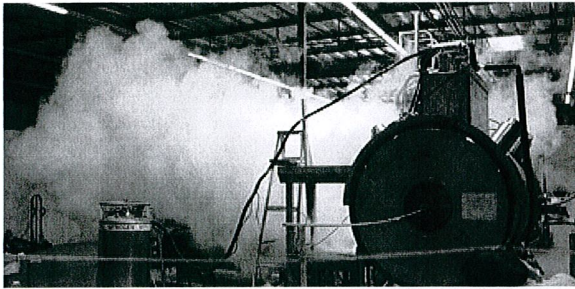

Figure 3: Quench during spectrometer solenoid training.

During this latest training, all five coils reached a current of 258 amps (94% of the qualifying current). At this point, it was discovered that one of the leads connecting to the Match 2 coil was in an open circuit condition. After disassembly of the cryostat and partial opening of the cold mass, the failure was found to be a burn-out of a superconducting cold lead just inside the vacuum/helium feedthrough. Further inspection of the cold mass revealed thermal damage to six of the nine resistors used in the passive quench protection system. The resistors overheated and buckled and caused localized charring of an adjacent G-10 insulating sheet (see Fig. 4). The quench resistors are included in the analysis that is described later in this paper.

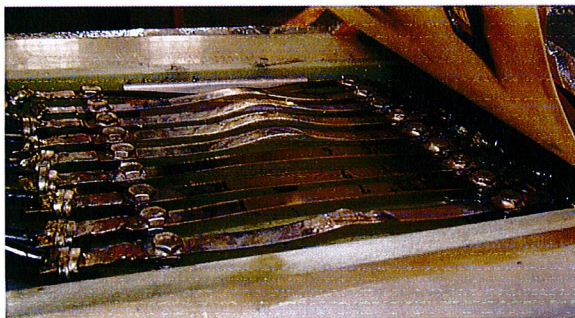

Figure 4: Heat damaged quench resistors.

One of the design requirements for the spectrometer solenoids is that the liquid helium in the cold mass must be maintained by the cryocoolers with no LHe boil-off during full current operation. The second stage of each of the Cryomech PT-415 cryocoolers is capable of supplying 1.5 watts of cooling power at 4K. As long as the heat leak into the magnet cold mass is less than the total cooling or re-condensing power of the coolers, the LHe will be maintained, and no boil-off will occur. During the recent magnet testing, detailed measurements of temperature, pressure and LHe level were made in order to assess the system heat loads in relation to the total cryocooling power available. Through these measurements, it was determined that the heat load into the cold mass was approximately 6 watts while the three cryocoolers could only remove 4.5 watts of heat. This shortfall in the cooling resulted in continuous LHe boil-off.

QUENCH AND ELECTRICAL ANALYSES

The present design of the spectrometer solenoid incorporates a series of diodes and resistors within the cold mass to serve as a passive quench protection system. A schematic diagram of the magnet electrical circuit is provided in Fig. 5 for reference.

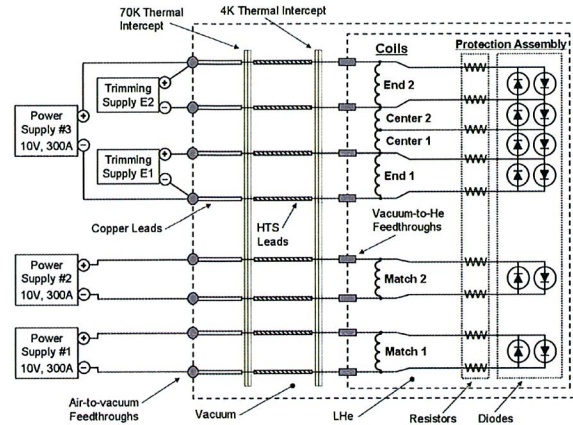

Figure 5: Magnet power supply and quench circuit.

As part of the overall assessment of the magnet design, the suitability of the passive magnet protection system is being reviewed and analyzed considering various operational regimes to verify to what degree the design can safely protect the system under reasonable fault scenarios. The analyses are being carried out using the Wilson code "quench" and the Opera-3D modeler with the QUENCH module [6].

First, a cursory analysis of various quench scenarios was developed. For basic quench simulations using the Wilson code, mutual inductances are ignored, but the total stored energy is used to estimate the hot-spot temperature and peak internal voltages. The code also estimates the longitudinal propagation velocity of the normal zone, and takes into consideration transverse propagation via a scaling of the longitudinal velocity. The calculated current decay during a quench with various coils operating is shown in Fig. 6.

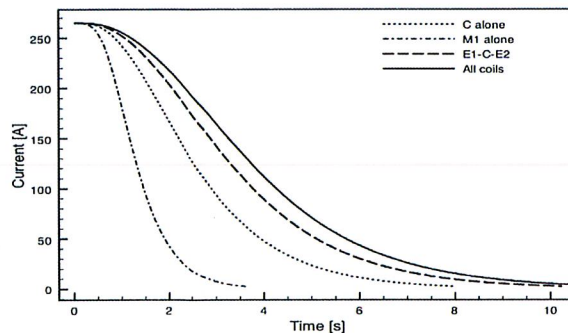

Figure 6: Current decay during a quench.

The simulations performed with this approach are typically conservative in nature as quenchback in the mandrel is not included. The hotspot temperatures

estimated in the simulations are reasonable for a coil of this type. The Wilson code predicts relatively high peak internal voltages in the case of series-connected operation during training of the system; however, the peak turn-to-turn voltage is likely to be significantly lower since the normal zone is expected to be large when the peak internal voltage occurs. Detailed 3D analysis is needed to better predict the voltages seen by the insulation.

For the next step of the analysis, we consider the impact of a quench on critical components, including the HTS leads, the cold leads and the quench protection resistors themselves. These components are analyzed in their current configuration, and design modifications will be recommended, where appropriate. The preliminary results of the analyses indicate that the cold leads will require stabilization through the addition of copper conductor. The analysis of the resistors in the passive quench system indicates that overheating will not occur during normal operation and quenching of the magnets. It appears likely that the overheating of the resistors occurred during the lead burn-out whereby a large fraction of the coil energy was dissipated in the resistors. As a protective measure, the quench resistors will likely be conductively cooled through heat-sinking to the body of the cold mass.

Finally, we are performing a more detailed analysis of the various quench scenarios to quantify the adequacy of the overall protection system through the use of a 3D model and the Opera QUENCH module. The 3D model (shown in Fig. 7) provides a verification of the Wilson code results while yielding a more detailed simulation of the quench process; this includes an accurate prediction of the layer-to-layer voltages and evaluation of the role of quenchback through the aluminum mandrel.

16/Feb/2011 08:05:37

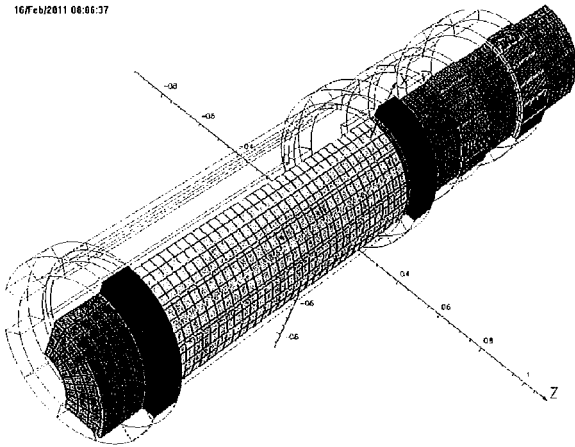

Figure 7: 3D quench analysis model.

MAGNET THERMAL ANALYSIS

A series of thermal calculations was carried out in order to characterize the spectrometer solenoid heat loads in its as-built condition. The focus of these calculations was the direct heat load into the cold mass, which leads to LHe boil-off. The dominant sources of heat include the

following: conduction through the cold mass supports, radiation from the 70K shield, direct radiation from 300K, heat leak from the cryocooler mounting scheme, the electrical leads, and direct shine through the fill and vent pipes. The updated calculations confirmed the measured heat load of ~6 watts. The calculations include the effects of the radiation shield being higher in temperature than expected (90 to 100K measured vs. 60 to 70K estimated).

The effects of a series of proposed design and assembly modifications were also assessed during this process. These modifications will likely include: improvement of the connection between the first stage of the cryocoolers and the radiation shield, increase of the thermal conductivity of the radiation shield, reduction of direct shine to the cold mass through the fill and vent lines by using baffles, and improved application of MLI. Through these and other improvements to the system, the total heat load on the cold mass is calculated to be reduced to less than 4 watts. Two additional pulse-tube cryocoolers will likely be added to the magnets to obtain adequate thermal margin by providing 7.5 watts of total power at 4K.

SUMMARY

The magnet quench analysis is being finalized, and recommendations are being developed. The thermal analysis of the spectrometer solenoids has resulted in a series of proposed design modifications that will reduce the heat leak into the cold mass while increasing the total amount of cryocooling power. The reassembly of the first of the two magnets is expected to commence shortly.

ACKNOWLEDGMENTS

The authors would like to acknowledge the design and fabrication efforts of our subcontracted magnet vendor, Wang NMR, Inc. of Livermore, CA. The development of the initial design concepts and detailed review by Pasquale Fabbriatore of INFN is acknowledged as well.

REFERENCES

- [1] G. Gregoire *et al.*, "MICE and International Muon Ionization Cooling Experiment Technical Reference Document"
- [2] M. A. Green *et al.*, "The Mechanical and Thermal Design for the MICE Focusing Solenoid Magnet System," *IEEE Transactions on Applied Superconductivity* **15**, No. 2, p. 1259, 2005.
- [3] M. A. Green *et al.*, "The Mechanical and Thermal Design for the MICE Coupling Solenoid Magnet," *IEEE Transactions on Applied Superconductivity* **15**, No. 2, p. 1279, 2005.
- [4] S. Virostek *et al.*, "Progress on the Fabrication and Testing of the MICE Spectrometer Solenoids," PAC09, Vancouver, Canada.
- [5] S. Virostek *et al.*, "Fabrication, Testing and Modeling of the MICE Superconducting Spectrometer Solenoids," IPAC10, Kyoto, Japan.
- [6] Cobham Technical Services, Vector Fields Software.

This document was prepared as an account of work sponsored by the United States Government. While this document is believed to contain correct information, neither the United States Government nor any agency thereof, nor The Regents of the University of California, nor any of their employees, makes any warranty, express or implied, or assumes any legal responsibility for the accuracy, completeness, or usefulness of any information, apparatus, product, or process disclosed, or represents that its use would not infringe privately owned rights. Reference herein to any specific commercial product, process, or service by its trade name, trademark, manufacturer, or otherwise, does not necessarily constitute or imply its endorsement, recommendation, or favoring by the United States Government or any agency thereof, or The Regents of the University of California. The views and opinions of authors expressed herein do not necessarily state or reflect those of the United States Government or any agency thereof or The Regents of the University of California.

This work was supported by the Director, Office of Science, Office of Fusion Energy Sciences, of the U.S. Department of Energy under Contract No. DE-AC02-05CH11231.