

UC Berkeley

Berkeley Scientific Journal

Title

The Mechanics of Timekeeping

Permalink

<https://escholarship.org/uc/item/7fs3p0sj>

Journal

Berkeley Scientific Journal, 21(1)

ISSN

1097-0967

Author

Liu, Katherine

Publication Date

2016

DOI

10.5070/BS3211033747

Copyright Information

Copyright 2016 by the author(s). All rights reserved unless otherwise indicated. Contact the author(s) for any necessary permissions. Learn more at <https://escholarship.org/terms>

Undergraduate



THE MECHANICS OF TIMEKEEPING

BY KATHERINE LIU

THE DEVELOPMENT AND MECHANICS OF MEASURING TIME IN HUMAN HISTORY

Since the earliest human civilizations, humans have kept time in one form or another, either through water clocks, sundials, hourglasses or candle clocks. Though primitive, these early forms of clocks were the building blocks of modern timekeeping technology. However, even though time is such an essential part of our lives, many people do not understand the mechanics underlying clock function. Archaeological evidence has shown that the Egyptians and Babylonians began measuring time 5,000 years ago. They started by recording the length of a day by following the sun across the sky and noting the phases of the moon.¹ The Egyptians also created calendars that had 12 months with 30 days each. These calendars even included 5 extra days every year to estimate the solar year. The next form of time measurement came with the invention of the sundial. The sundial, which has been invented independently

by all major cultures, works by indicating the time of day by the length and direction of a shadow cast by the sun's light. But because such devices cannot work at night, the sundial's counterpart, the water clock, was created to tell time during the night. The water clock is a basin of water that lets water drip from a small hole near the base of the basin. Lines were drawn inside the basin walls to denote sections of time so as the water level dropped, it would gradually reveal lines above the water level, thereby indicating the time.¹

The earliest clocks, along with the sundial and water clock, are the hourglass and candle clocks. We often see these in films and animation to give an archaic setting. However, even these seemingly familiar and simplistic clocks are quite impressive in being able to accurately keep time even before the physics regarding water flow and planetary motion were understood. The candle clock works similarly to the water clock in that the wax of a candle is

melted down and the height of the candle at different moments measure how much time has passed.¹ More modern forms of timekeeping include pendulums, pocket watches, and classroom clocks. These are still relatively simple compared to today's digital clocks and beyond, but are equally interesting and important. Pendulums are quite distinguished in function from clocks and pocket watches in that they don't have as many small components that aid it in telling time. The main parts of a pendulum are the rod and weight which together swing side to side in an oscillating motion.² To maintain the same oscillating rate, there are specific configurations not seen from the outside. But this does not prevent a pendulum clock from eventually lagging in timekeeping. So, occasionally, a clockmaker or clock owner will need to reconfigure the cogs in a pendulum so they read time accurately. Pocket watches and clocks are unique from pendulums. Clock mechanics



“Time is a way to track the irreversible occurrences in our lives, from deaths, to food eaten, to water spilled”

are interesting in that there are many different configurations, called escapements, of clock pieces. These escapements have different efficiencies, energy conversion, and accuracy.⁶ Several such escapements worth noting are the Verge Escapement, and the Grasshopper Escapement.²

The Verge Escapement is likely the oldest clock escapement and consists of a crown-shaped wheel (the escape wheel) that turns vertically with its ‘teeth’ protruding to one side. These teeth push a pallet (a rod with parts that can be pushed by the crown-wheel’s teeth) causing the pallet’s rod (the verge) to rotate in a single direction. As the crown-wheel continues to rotate, it pushes the pallet into completing many cycles, and each cycle translates into a small movement of the hands on a clock moving clockwise.²

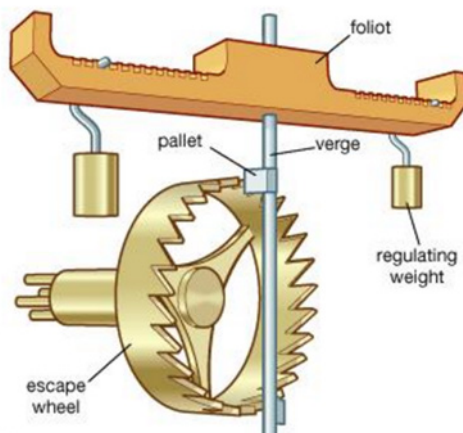

Similar yet different from the Verge Escapement is the Grasshopper Es-

capement. This escapement has mostly the same configuration as the Verge Escapement, only all the wheels and pallets are put on their side: it runs horizontally. The name of this escapement hints at the image of the escapement: the pallet position and motion in relation to the escape wheel looks like the leg of a grasshopper as well as the coupling rods on a train, connecting the wheels and rotating in place.²

All of these different clock escapements will eventually require repair because over time, their efficiency decreases. With so many small metal parts pushing against each other, friction is inevitable, which is the main source of energy inefficiency in clocks.⁶

More modern forms of timekeeping and clock mechanics include the atomic clock and quantum clocks. Previously described clocks and timekeeping devices relied on physical characteristics to read time. But many clocks such as the atomic and quantum clocks, use ions, atoms, and radiation waves that are not visible to precisely measure time.

Inside an atomic clock, atoms of specified element, such as cesium, are pushed through a tube to an area where they are exposed to radio waves of a specified frequency. The energy from these radio waves cause the cesium atoms to resonate and change their energy state. A cesium detector at the the end of the tube registers every time a cesium atom reaches it, and will tick of a second of time once a certain frequency of cesium atoms striking the detector is met.⁵

A quantum clock is a specialized type of

atomic clock in that instead of using atoms of an element, it uses single ions to absorb the radiation and record the frequency and subsequently tick of seconds based on this frequency of registered ions.³

It is important to think about how these devices impact how we perceive time. Time to most people is a common occurrence that has no special meaning other than the fact that it is how we run our daily lives. What many people haven’t thought about is that time is mostly just imagined. Aristotle once described time to be a measure or number of some sort of motion.

This means that time is not an independent entity and cannot exist separate from other things in the world.⁴ Time is directly related to the objects in our lives and is solely there to measure the motion of those objects. This notion takes time to digest, but fundamentally greatly makes sense.

Time is a way to track the irreversible occurrences in our lives, from deaths, to food eaten, to water spilled. But this then asks the question: why do we bother to measure time to intricately using high-tech clocks and other precise machines if time isn’t ‘really’ there? And though there is no clear answer, and is subject to personal views, a good reason shared by most people is that time creates a sense of order in society and daily life. If we didn’t have a schedule to follow, people would just wander aimlessly all day long. They wouldn’t value their lives because they wouldn’t realize that it was passing so quickly. Days would melt together and we would never have a sense of purpose if we didn’t keep time.

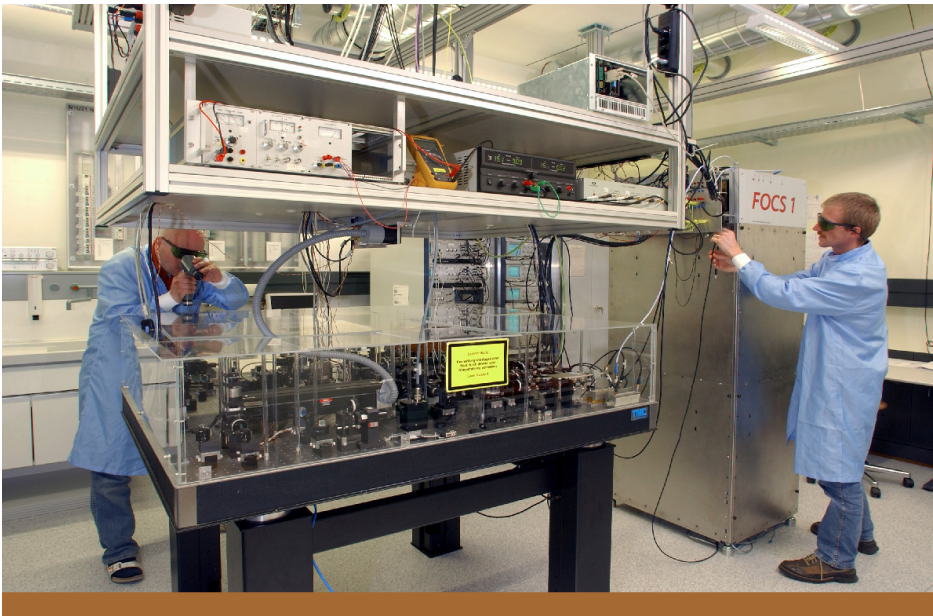

Atomic clock in a laboratory

References

1. Andrewes, W. J. (2006, February 1). A Chronicle Of Timekeeping. Retrieved October 10, 2016, from <https://www.scientificamerican.com/article/a-chronicle-of-timekeeping-2006-02/>
2. Du, R., & Xie, L. (2012). A Brief Review of the Mechanics of Watch and Clock. *History of Mechanism and Machine Science The Mechanics of Mechanical Watches and Clocks*, 5-45. doi:10.1007/978-3-642-29308-5_2
3. Erker, P., Mitchison, M. T., Silva, R., Woods, M. P., Brunner, N., & Huber, M. (n.d.). Autonomous quantum clocks: How thermodynamics limits our ability to measure time. Retrieved October 10, 2016, from <https://arxiv.org/pdf/1609.06704v1.pdf>.
4. Gale, R. M. (1967). *The philosophy of time: A collection of essays*. Garden City, NY: Anchor Books. Retrieved October 28, 2016, from [https://books.google.com/books?hl=en&lr=&id=rWChCwAAQ-BAJ&oi=fnd&pg=PA1&dq=philosophy of time&ots=2jU1n9LCw8&sig=M6cvk-d4up4vmThgCpfG7e27kC-A#v=onepage&q&f=false](https://books.google.com/books?hl=en&lr=&id=rWChCwAAQ-BAJ&oi=fnd&pg=PA1&dq=philosophy+of+time&ots=2jU1n9LCw8&sig=M6cvk-d4up4vmThgCpfG7e27kC-A#v=onepage&q&f=false).
5. Gessner, W. (2015, November). Ideal Quantum Clocks and Operator Time. Retrieved October 10, 2016, from <https://arxiv.org/ftp/arxiv/papers/1305/1305.0949.pdf>.
6. Headrick, M. V. (1997). Clock and

Watch Escapement Mechanics. 1-87. Retrieved October 3, 2016, from <http://www.nawcc-index.net/Articles/Headrick-Esc-Mechanics.pdf>

Image Sources

Banner Image: <http://cdn.wonderfulengineering.com/wp-content/uploads/2014/10/time-wallpaper.jpeg>
 Sundial Image: <https://images.robertharding.com/preview/RM/RH/HORIZONTAL/206-768.jpg>
 Verge Escapement Image: <https://blog.klockit.com/2015/05/27/making-time-the-great-escapement/>
 Atomic Clock Image: <http://www.urania.be/sites/default/files/Tijd%20en%20seconden%20huidige%20atoomklok%20atomuhr%20FOCS%201.png>